



[RDL](#)



[Document](#)



[Download](#)

[Homepage](#) [Information](#) [Instructions](#)

*FM 55-65

**Field Manual
NO. 55-65**

**HEADQUARTERS
DEPARTMENT OF THE ARMY
Washington, DC, 3 October, 1995**

FM 55-65

STRATEGIC DEPLOYMENT

Table of Contents

PREFACE

Chapter 1

MOBILIZATION AND STRATEGIC DEPLOYMENT OVERVIEW

[Force Projection](#)

[Mobilization](#)

[Deployment Phases](#)

[Deployment Planning](#)

[Deployment Command Channels](#)

Chapter 2

STRATEGIC MOBILITY AUTOMATION SUPPORT SYSTEMS

[Strategic Planning Systems](#)

[Army Mobilization and Operations Planning Execution System](#)

[Global Transportation Network](#)

[Transportation Coordinator-Automated Information for Movements System](#)

[Transportation Coordinator-Automated Command and Control Information System](#)

[TC-ACCIS Airlod Module](#)

[Computer Aided Loading and Manifesting System](#)

[Computerized Movement Planning and Status System](#)

[Worldwide Port System](#)

[Improved Computerized Deployment System](#)

[Automated System for Processing Unit Requirements](#)

[Department of the Army Movement Management System-Redesign](#)

[Unit Movement Data Transactions for Crisis Response](#)

[Personnel Deployment Planning Systems](#)

Chapter 3

STRATEGIC DEPLOYMENT PLANNING AND PREPARATION AT MACOM LEVEL AND BELOW

[Levels of Responsibility](#)

[Movement Planning Process](#)

[Support Requirements](#)

[Unit Alert](#)

[Soldier Readiness Processing](#)

[Personal Responsibilities](#)

[Individual Clothing and Equipment Inspection](#)

[Security](#)

[Overseas Orientation](#)

[Clearance From the Installation](#)

[Maintenance](#)

Chapter 4

AIR MOVEMENT OPERATIONS

[Types of Air Movements](#)

[Air Force Airlift Aircraft](#)

[Aircraft Characteristics](#)

[Civil Reserve Air Fleet Aircraft](#)

[The 463L Cargo System](#)

[Unit Air Movement Planning](#)

[Aircraft Load Planning](#)

[Load Planning Factors](#)

[Air Terminals](#)

[Aircraft Loading Guidance](#)

[Safety](#)

Chapter 5

CONVOY OPERATIONS

[Convoy Organization](#)

[Convoy Personnel](#)

[Vehicle Placement](#)

[Convoy Communications](#)

[Convoy Identification](#)

[Safety Equipment and Warning Devices](#)

[Final Actions Before Departure](#)

[Driver Preparation](#)

[Road Movement Planning](#)

[Convoy Movement Requests](#)

[Preparation of the Graphic Strip Map](#)

[Convoy Execution](#)

Chapter 6

RAIL MOVEMENT OPERATIONS

[Responsibilities](#)

[Rail Equipment](#)

[Rail Site Preparation](#)

[Rail Loading](#)

[Railcar Inspections](#)

[Restraining Materials](#)

[Loading Vehicles on Railcars](#)

[Unloading Railcars](#)

Chapter 7

OPERATIONS AT THE PORT OF EMBARKATION

Section I - SEA

[Responsible Agencies](#)

[Marshaling Area](#)

[Staging Area](#)

Section II - AERIAL

[Marshaling Area Activities](#)

[Alert Holding Area](#)

[Call Forward Area](#)

[Loading Ramp Area](#)

Chapter 8

CONVOY OPERATIONS

[Reception and Onward Movement Processes](#)

[Reception at the APOD](#)

[Reception at the SPOD](#)

[Onward Movement](#)

Chapter 9

REDEPLOYMENT

[Redeployment Responsibilities](#)

[Redeployment Process](#)

[Redeployment Requirements and Considerations](#)

[Redeployment Phases](#)

[Redeployment Activities](#)

[CONUS POD Activities](#)

[APPENDIX A](#)

[APPENDIX B](#)

[APPENDIX C](#)

[APPENDIX D](#)

[APPENDIX E](#)

[APPENDIX F](#)

[APPENDIX G](#)

[GLOSSARY](#)

[BIBLIOGRAPHY](#)

[AUTHENTICATION](#)

Distribution Restriction: Approved for public release; distribution is unlimited.
--

*This publication supersedes FM 55-65, 10 May 1989.

[RDL](#)[Table of](#)[Document](#)[Download](#)[Homepage](#) [Contents](#) [Information](#) [Instructions](#)

PREFACE

This manual provides the tactics, techniques, and procedures that major commands and units must follow to successfully deploy by all modes of transportation. It applies to the total US Army forces deploying to any destination and to deployment planners and executors at all levels.

This manual provides strategic deployment doctrine that is consistent with [FM 100-5](#) and [FM 100-17](#). [FM 100-5](#) is the capstone of Army doctrine. It describes force projection as "the demonstrated ability to rapidly alert, mobilize, deploy, and operate anywhere in the world." [FM 100-17](#) focuses on mobilization, deployment, redeployment, and demobilization from an overarching doctrinal perspective.

As the national security strategy states, the ability to project power will underpin our strategy more than ever. We must, through strategic mobility, be able to deploy substantial forces to any part of the world. We must be capable of sustaining them in areas where pre-positioning of equipment may not be feasible or where adequate bases may not be available. We must also sustain them in areas where a poorly developed industrial base and infrastructure exist. We must be able to move personnel and material to the scene of a crisis at a pace and numbers sufficient to achieve quick, decisive mission success.

The proponent of this publication is the US Army Transportation School. Send comments and recommendations on DA Form 2028 (Recommended Changes to Publications and Blank Forms) directly to Commandant, US Army Transportation School, ATTN: ATSP-TDJ, Fort Eustis, Virginia 23604-5001.

Environmental issues are a major concern of the US Army. With emerging new laws and regulations, these issues will continue to have a growing impact on US Army operations.

Unless this publication states otherwise, masculine nouns and pronouns do not refer exclusively to men.



[RDL](#) [Table of Contents](#) [Document Information](#) [Download Instructions](#)

[Homepage](#) [Contents](#) [Information](#) [Instructions](#)

Chapter 1

Mobilization and Strategic Deployment Overview

This chapter provides an overview of the AC and RC mobilization and joint deployment planning process (see [Figure 1-1](#)). It focuses on the plans and procedures by which all Army components are transitioned to a state of readiness for war or other national emergencies.

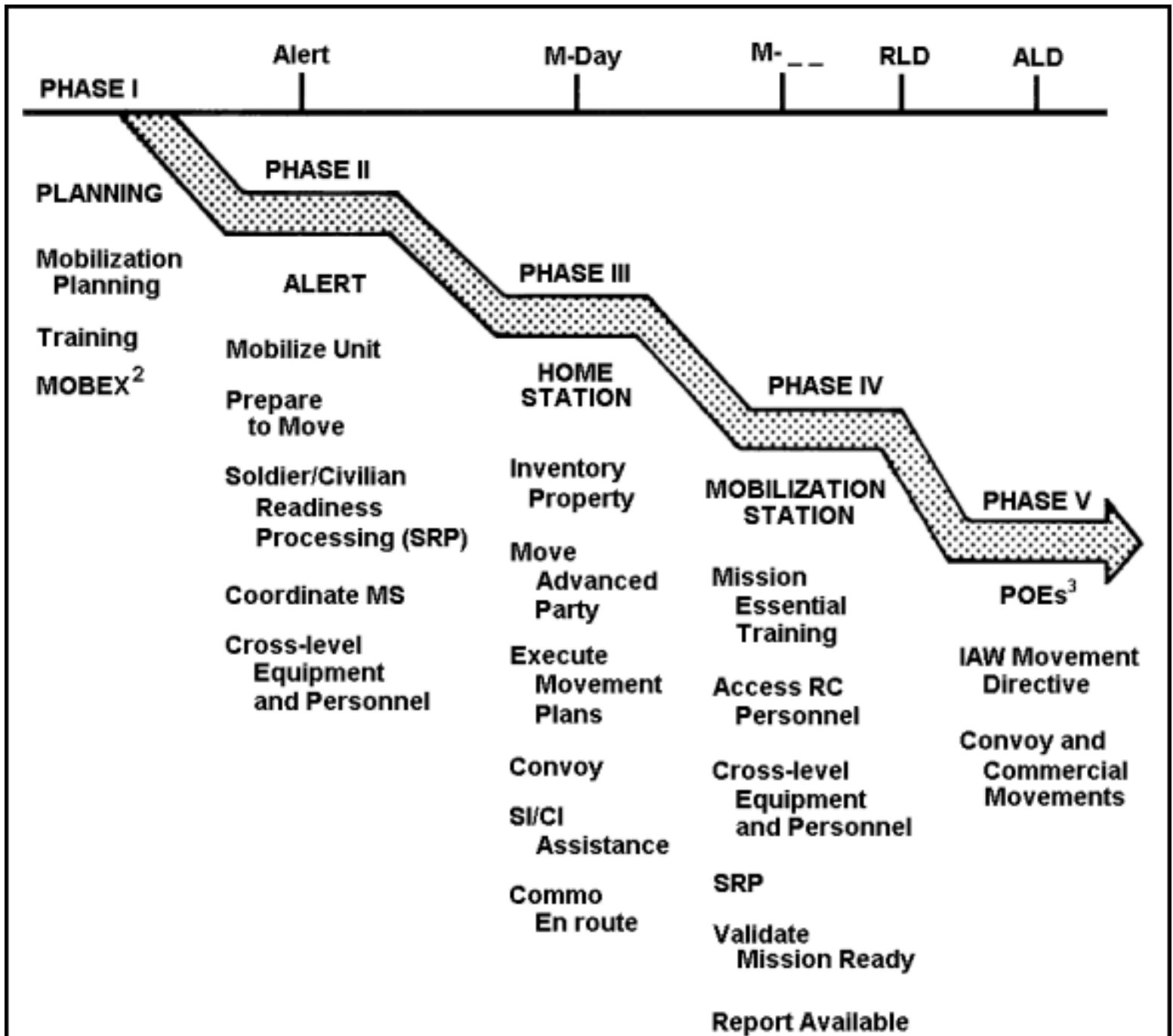

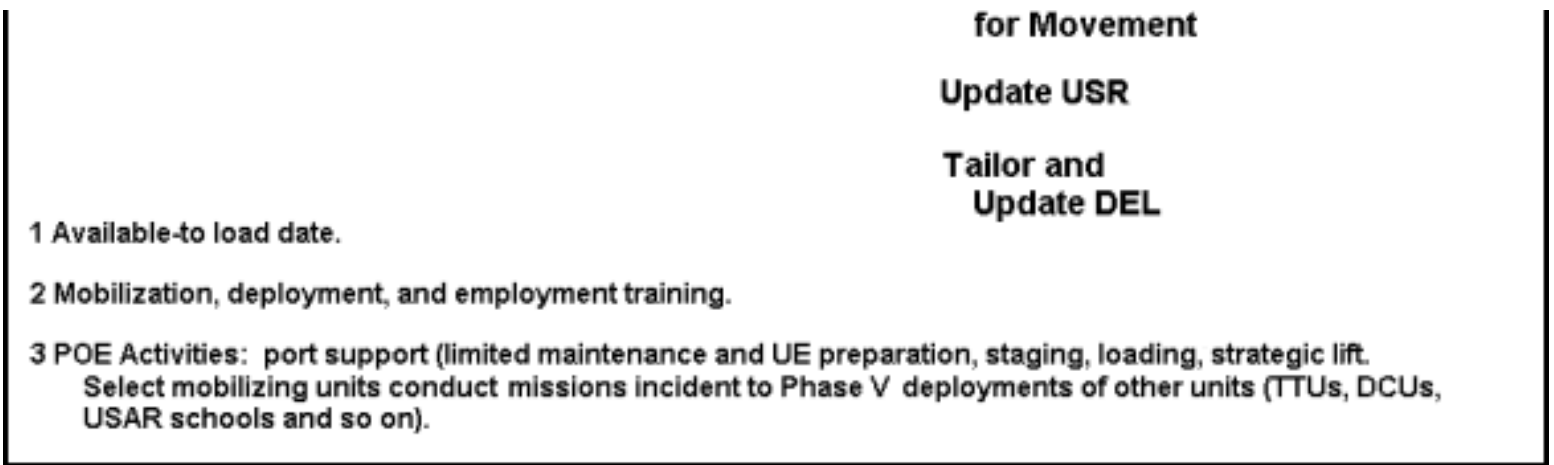

Figure 1-1. Mobilization and Joint Deployment Planning Process

In response to a military need or crisis, strategic deployment is the strategic relocation and concentration of forces and their support base (manpower and logistics). Strategic deployment consists of the movement from CONUS into a theater, from CONUS to CONUS, from OCONUS to OCONUS, or from OCONUS to CONUS.

The Army has global responsibilities. Its credibility depends on its strategic deployment capability. The mission of getting equipment, personnel, and supplies to the right place at the right time is vital. Army forces must always be ready and able to rapidly mobilize, deploy, and conduct operations at a pace and in sufficient numbers to achieve rapid mission success. This chapter provides an overview of strategic deployment, responsibilities, deliberate planning, crisis response, and the phases of deployment.

FORCE PROJECTION

1-1. Force projection operations are directed by the NCA to meet specific events affecting US national interests. Force projection is the demonstrated ability to rapidly alert, mobilize, deploy, and operate anywhere in the world. Strategic deployment is the component of force projection that focuses on the physical movement of forces. Deployment technically ends with the arrival of forces and sustainment in the theater.

1-2. Force projection does not end until the mission is completed and the last soldier returns. Deployment is not an isolated activity. It includes predeployment activities, movement to the POE, strategic lift, theater reception, and onward movement. All deployment planners must consider the force projection mission. Army units must be prepared for rapid task organizing, echeloning, and tailoring for deployment, operations, and the return of forces to their HSs.

1-3. The primary military organization that conducts tactical operation as a part of force projections are JTFs. Within a JTF, the corps is the principal Army force. A corps generally has the command and control, combat, CS, and CSS to execute a force projection mission. In certain situations, the Army will have an operational level HQ between the corps and the JTF to focus on campaign planning and logistics described in FM 100-16. The mix of forces must be properly sequenced to meet the mission and support RSO&I, and sustainment of arriving forces.

MOBILIZATION

1-4. For the US Army, mobilization is the process that provides the supported combatant commander with three basic components required for mission accomplishment. The three components are forces (units), manpower (individuals), and logistic support. Mobilization is a five-phased process designed to be a concurrent and continuous operation rather than a sequential process. The five phases include the following:

- Planning.
- Alert.
- Home Station.
- Mobilization Station.
- Port of Embarkation.

PHASE 1 - PLANNING

1-5. This phase concerns both AC and RC efforts during peacetime to plan, train, and prepare to accomplish all required mobilization and deployment tasks. Planning for mobilization includes unit operational requirements, training requirements, personnel and equipment status, and the impact of mobilization on soldiers, their families, and the community. During the planning phase, units are expected to complete as many SRP actions as possible. Examples include medical, dental, financial, legal, family support activities, and family care plans. Logistically, units may have shortages of authorized personnel, equipment, supplies, or other items such as PLL. Commanders should recognize and initiate actions to resolve these areas of concern. This phase ends with an alert notification.

PHASE 2 - ALERT

1-6. This phase of mobilization begins when a unit receives notice of a pending order. The unit is mobilized, actions to complete SRP begun in Phase 1 are implemented, a final personnel screening is conducted for deployability, and personnel and equipment may be cross-leveled to bring alerted units to a minimum deployability criteria by higher command levels after DA DCSOPS approval. RC units coordinate with and prepare to move to their assigned MS. This phase ends with the unit's entry on active duty.

PHASE 3 - HOME STATION

1-7. This phase begins with AC preparation for deployment and RC preparation for the unit's entry on active federal duty. AC and RC unit activities at HS include an inventory of unit property, dispatching the advance party to the MS, load-out, convoy clearance to the MS, any required SI or CI assistance, activate the plan for retrieval of equipment in maintenance or on loan, and execution of the movement plan. This phase ends when the unit arrives at the MS.

PHASE 4 - MOBILIZATION STATION

1-8. This phase begins with unit arrival at the MS or mobilization site. Command of the arriving unit passes from the appropriate CONUSA to the MS command authority. SI and MS unit actions include continued SRP processing, other personnel and equipment processing as required, and conduct of mission essential training. Units conduct individual and collective training tasks and update USR, movement data, and the DEL. Units are validated and reported as available for movement to the POE. This phase ends when the unit arrives at the POE.

PHASE 5 - PORT OF EMBARKATION

1-9. This phase begins with the arrival of the unit at its POE. Unit actions at the APOE or SPOE include preparing and loading equipment and manifesting and loading personnel. This phase ends with the departure of personnel and equipment from the POE.

DEPLOYMENT PHASES

1-10. Every deployment is unique. Many aspects of a deployment overlap and can happen simultaneously. They can be abbreviated and adjusted as required. However, the fundamental planning process of deploying the force does not change. [Figure 1-2](#), outlines the five phases of deployment. These phases include the following:

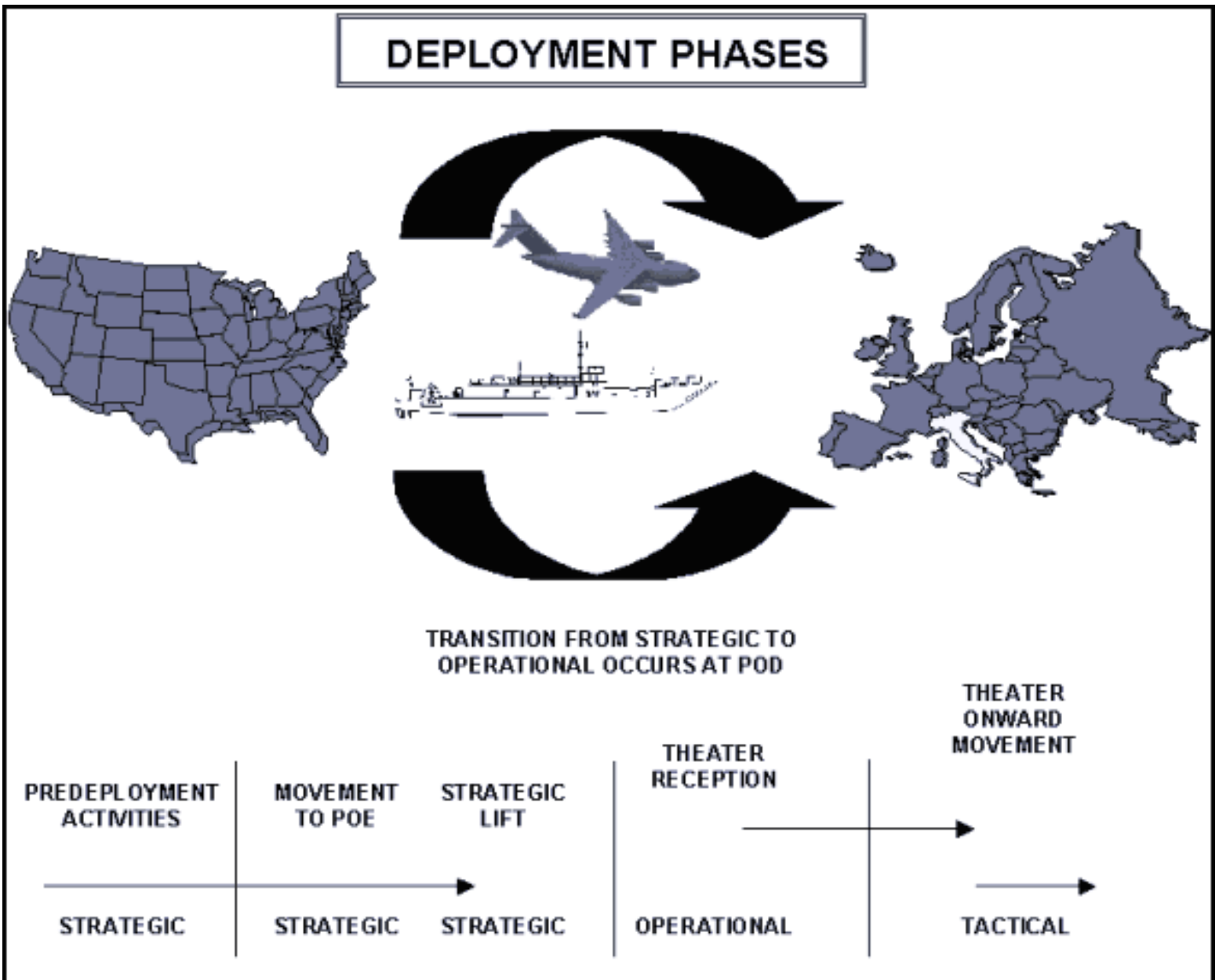

Figure 1-2. Force Projection Operations

- Predeployment activities.
- Movement to the POE.
- Strategic lift.
- Theater reception.
- Theater onward movement.

PHASE I--PREDEPLOYMENT ACTIVITIES

1-11. Predeployment and deployment activities are a command responsibility. Predeployment activities include everything done at all command echelons to prepare forces for deployment. They are essentially constant and ongoing activities. Examples are training validation, deployment planning, task organization, equipment maintenance, and SRP. Transportation personnel, staffs, and units are an essential part of the deployment team.

1-12. Commanders, staffs, and units plan, train, and rehearse for deployment. Units must conduct routine collective deployment training to ensure they are prepared to deploy the forces, individual manpower, and materiel to accomplish the mission. In keeping with the fundamentals of [FM 100-5](#) and [FM 100-17](#), commanders constantly review and adjust METLs to make certain they reflect mobilization and deployment tasks and other critical elements of force projection. Such ongoing predeployment activities can ensure an Army of fully-trained, well-led, properly-equipped units and soldiers, one that is ready to rapidly mobilize and deploy.

1-13. Installations and supporting commands must continue to plan and provide geographic support and assistance to deploying units. Assistance should include functions such as PSA, A/DACG, and logistics support.

1-14. Both active and reserve component units may deploy. RC units must first be mobilized, which is contingent upon Presidential and/or Congressional action. Mobilization of RC units may begin during predeployment activities or during any later phase. Mobilization and deployment is a fluid process that starts with planning and extends through arrival in the AO. A key to successful deployment is planning from the highest level of the government down to the unit level. Because of competition for limited assets, US forces at all levels of command depend on each other to ensure deployment is rapid and effective. Mobilization and deployment planning includes providing accurate unit movement requirements in the TC-ACCIS.

1-15. Upon warning of mobilization or deployment, units begin to build upon prior training by focusing on the missions and conditions anticipated during the contingency. Immediate planning begins concerning such activities as supply and transportation requirements, equipment and personnel preparation, and training. Not to be overlooked during planning is making certain a solid support base for families is in place and ready to function.

1-16. Commanders evaluate the METT-T to provide a versatile force that is prepared to meet all known and implied tasks. They prioritize strategic lift requirements to meet the demands of the specific crisis, which permits the CINC or JFC to establish the deployment sequence.

1-17. The UMO and the supporting transportation staffs help the commander coordinate the support requirements needed for an effective and efficient deployment. Advance preparation and requisition of unit equipment and supplies ensures a smooth flow of materiel from the HS or SI. This preparation includes the following:

- Selecting equipment and supplies.
- Inspecting vehicles for serviceability, safety, and presence of basic issue items.
- Checking, preparing, and placing MSLs on vehicles, equipment, and containers.
- Stuffing, blocking, and bracing of vehicles, equipment, and containers.

1-18. Unit equipment being transported by commercial rail or highway is prepared according to ITO procedures. Simultaneously, unit personnel continue to complete

administrative, medical, legal, and general personnel processing actions.

1-19. Unit training is validated and continued. Or, additional training takes place at the MS to achieve mission capability status in the shortest time possible for deployment.

1-20. The data supplied by TC-ACCIS is of primary importance in processing transportation requirements. TC-ACCIS is also useful in preparing convoy march tables, unit equipment manifests, materiel requirements lists, and the maintenance of AUELs and DELs. [Figure 1-3](#) outlines the factors which influence this process.

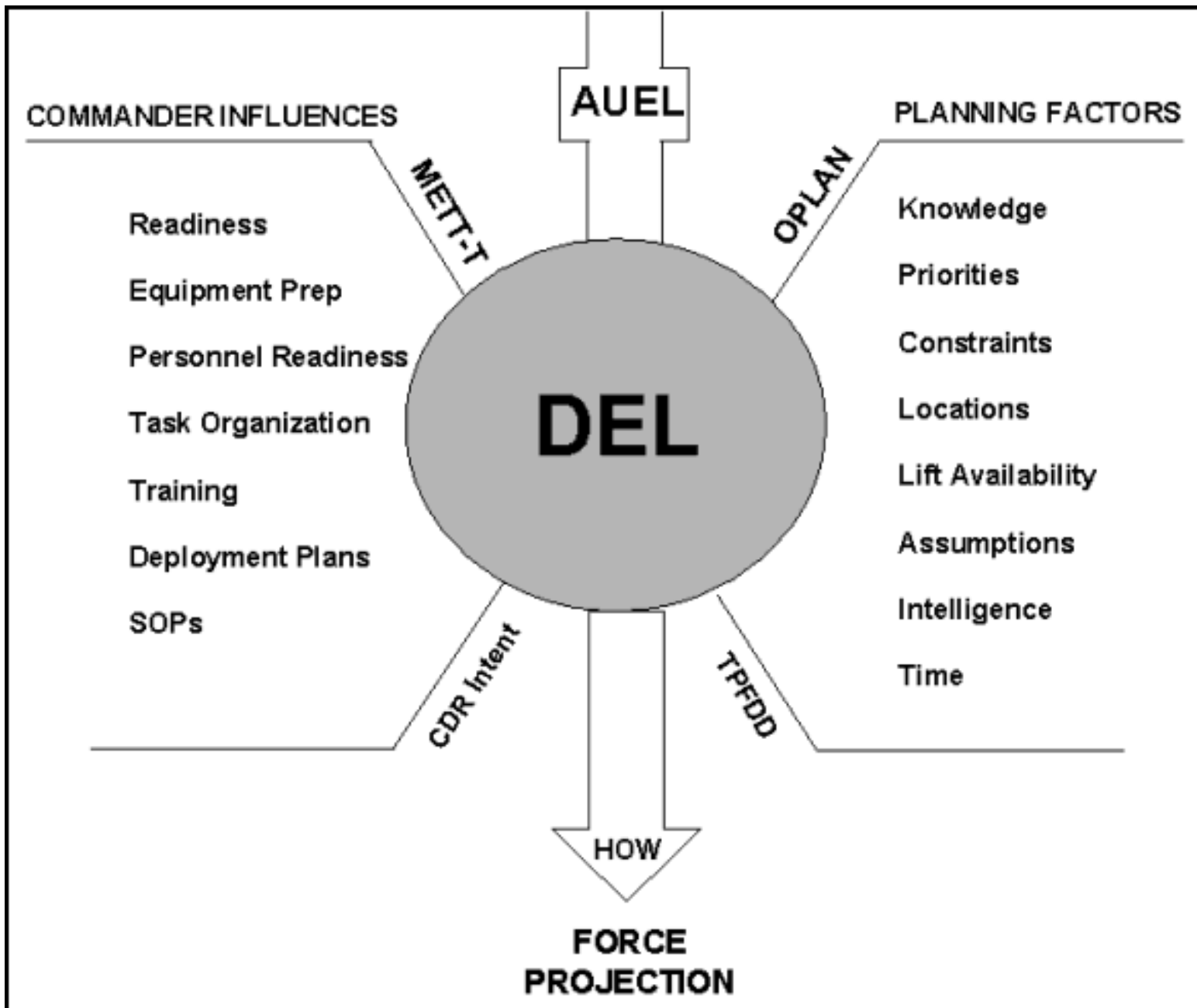

Figure 1-3. Factors that Influence Force Projection

PHASE II - MOVEMENT TO THE POE

1-21. Phase II begins with receipt of a movement directive that specifies the dates the unit is required to arrive at the POE. The units are then validated and configured for

movement. This is the tailoring process.

1-22. Units submit required documents (see [Appendix A](#)) to permit movement to the POE and conduct final inspections. While equipment is being inspected, shipping documentation is verified using LOGMARS technologies. This process ensures the TCN reflects the units planned shipment on the AUDEL and DEL. Such information is essential in developing stow plans, routings, and movement resourcing.

1-23. Actual deployment from installations can begin once notification is received. Units move according to the movement schedule to the POE for processing. This phase ends with the arrival and processing of personnel and equipment at the POE and loading on strategic air and sealift.

PHASE III--STRATEGIC LIFT

1-24. In Phase III, units are deployed to the POD. Depending on the threat to arriving forces or need for pre-positioned assets before theater arrival, forces may assemble at ISBs for receipt of pre-positioned stocks/equipment or unit task organizing. Normally troops are deployed by air and equipment by sea. The estimated arrival of equipment at the SPOD normally dictates when personnel are airlifted to the theater. Synchronizing the arrival by air or sea into the AOR at the SPOD and personnel arriving at the APOD is the responsibility of the USTRANSCOM.

Sealift

1-25. Sealift capability involves a variety of vessels, such as RO/RO ships, fast sealift ships, RRF ships, pre-positioned force ships, and chartered ships. RO/RO vessels are available in very limited numbers and constitute the bulk of the military required surge sealift support. When unit equipment arrives at the SPOE, it comes under the control of the MTMC, the DOD single port manager for common user ocean ports (see [Chapter 7](#)).

1-26. Although processing may differ from port to port, equipment arriving at the SPOE goes to a marshaling area under the control of the deploying unit or port commander. Final preparation of unit equipment and reconfigurations for loading takes place in the marshaling area. This includes activities such as checking fuel levels, HAZMAT inspections, and verification of the DEL for last-minute changes to cargo dimension or weight.

1-27. All equipment not meeting MTMC standards, such as items with improper MSLs, maintenance problems, or other deficiencies, will not be processed until the faults are corrected and the equipment reinspected. As loading begins, equipment is sent from the marshaling area to a staging area based on a call forward plan. The MTMC port commander then assumes control of the equipment. The equipment is segregated according to the vessel stowage plan, loaded, positioned, and tied down.

Airlift

1-28. Strategic airlift support is essentially a joint function between Army and Air Force activities. Airlift is used primarily to transport personnel, selected vehicles, and unit equipment. Strategic airlift is the responsibility of the AMC. Wartime and contingency APOEs and APODs are designated by unit commanders within their theaters of operation (with AMC concurrence).

1-29. The procedures involved in strategic airlift are similar to those for seaport embarkation. Unit equipment is initially placed in a marshaling area. In the marshaling area, personnel and cargo manifests are prepared, equipment and vehicles are assembled into chocks or loads, and moved to the alert holding area. At the alert holding area, the DACG accepts the Army's equipment and supplies. They inspect them and ensure all passengers are accounted for and available.

1-30. From the alert holding area, the load is directed to the call forward area where a joint inspection is carried out by the aerial port element of the TALCE and the DACG. Final briefings are given, manifests reviewed for accuracy, and personnel and baggage escorted to either commercial or military air assets for loading. The aerial port element of TALCE then receives the cargo at the airfield loading ramp/ready line and, in conjunction with the loadmaster, loads and secures it aboard the aircraft.

PHASE IV--THEATER RECEPTION

1-31. At the POD, units and equipment are processed and moved to marshaling areas for onward movement configuration. Units move to their marshaling areas for receipt of pre-positioned stocks/equipment and/or unit task organizing into combat configuration. This is completed as close to the TAA as practical. Throughout the reception process, the end result is the quick, effective projection of the force.

1-32. At SPODs, the port commander works closely with HNS and multi-service personnel to discharge equipment. Equipment, supplies, and materiel are held in a terminal staging area, then moved to a marshaling area outside the terminal. The deployment force receives its equipment and supplies at the marshaling area.

1-33. Like departure airfield operations, the arrival at APOD consists of systematic actions that take place in distinct AOR. When the deploying unit arrives at the APOD, the TALCE coordinates the unloading process in the off-loading ramp area and turns clearance responsibility over to the AACG or ATMCT. Personnel are received and processed and equipment assembled into chocks, inspected for completeness, and released to the deploying unit for reconfiguration and onward movement.

PHASE V--THEATER ONWARD MOVEMENT

1-34. This phase begins when units are configured to move to their final destination, normally a TAA. During this critical phase of deployment, the availability of transportation again takes an important role to keep units and supplies moving forward directly to the area of employment.

1-35. Theater onward movement is accomplished through a carefully devised

movement program that employs convoy, rail, and HN contract assets to ensure the forward and concurrent movement of troops and supplies. Convoys of vehicles carrying critical warfighting supplies are established for onward movement. Truck terminal and trailer transfer points are established for use in line-haul or relay operations. Rail transport, when available, will also be used to transport heavy tracked vehicles and other large items of equipment as far forward as possible. Heavy equipment transporters complete the movement to destination.

1-36. Deployment continues through employment. Forces, individual manpower, and materiel continue to deploy to the theater either as a prelude to, or concurrent with, operations. Forces already in the theater may be required to deploy to other locations. The deployment process may not end until late into redeployment.

DEPLOYMENT PLANNING

1-37. Deployment is an integral part of the MDRD process described in [FM 100-17](#). Deployment comprises those activities required to prepare and move the force and its sustainment from CONUS, from OCONUS, or a combination of both, to the AOs as ordered by the appropriate command authority.

TYPES OF PLANNING

1-38. Deployment is a joint operation in which the Army provides forces to the supported CINC of a unified command in response to direction of the NCA. Joint operational planning is a coordinated process used by the commander to determine the best method of accomplishing the mission. In peacetime, the process is called deliberate planning. In crisis situations, the process is called CAP. The overall process of CAP parallels that of deliberate planning, but is much more flexible to accommodate requirements to respond to changing events. Both deliberate planning and CAP are conducted within JOPES.

Deliberate Planning

1-39. The supported CINC develops deliberate plans (see [Figure 1-4](#)) on a routine basis for potential contingencies within his AOR. Each plan has TPFDD. During a crisis, the CINC may update the plan with current information and in conjunction with supporting organizations, creates an OPORD for execution. Unit deployment planning describes the movement of forces and support from the HS or installation to the POE.

THE DELIBERATE PLANNING PROCESS

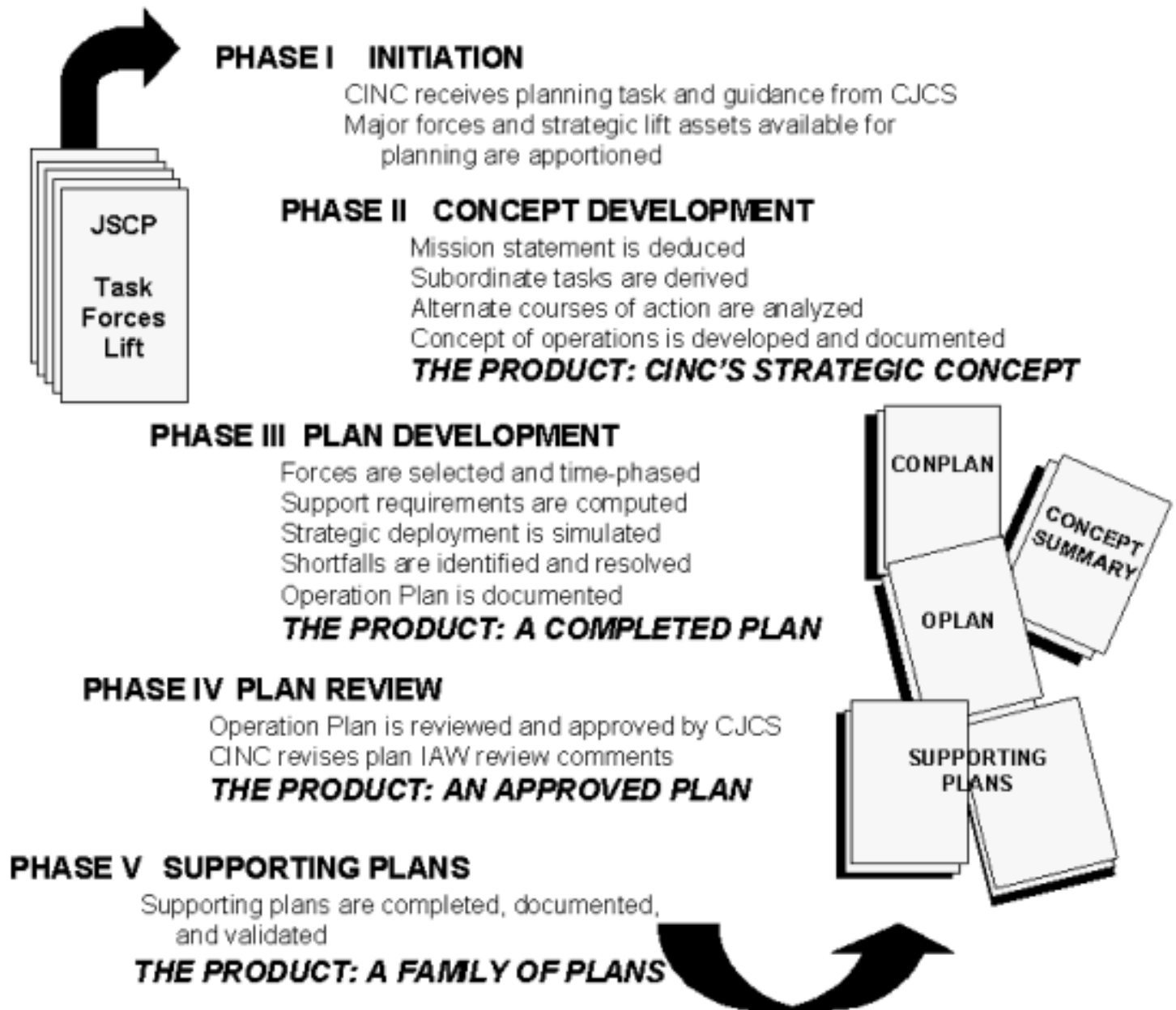

Figure 1-4. Deliberate Planning

1-40. The time-phasing of the TPFDD is prepared using reverse planning, which begins with the "ultimate" destination (the geographic location where the force is to be employed). The RDD is the date, assigned by the CINC, that the force must arrive and unload at its destination. USTRANSCOM, its components, and the deploying forces use the RDD to determine critical interim dates, such as the date the unit must do the following:

- Depart the origin installation, MS, or HS.
- Arrive at the POE.
- Arrive at ISBs.
- Arrive at the POD.

1-41. While active and reserve components plan for deployment, RCs also plan for mobilization. Mobilization planning details the mobilization of reserve forces and their movement from their HS to their MS.

1-42. The Army also provides forward presence forces to joint commands throughout the world to assert US global influence where required. These forces are reinforced by CONUS-based or other forward presence forces in a supporting role. They may also deploy to another AO in a supporting role. Forward presence forces must plan for both their supported and supporting roles.

Crisis Response

1-43. Once a force projection mission is received, Army units are tailored based on METT-T and prepare for deployment (see [Table 1-1](#)). The availability of strategic airlift and sealift, among other factors, drives the deployment flow. To the extent possible, supported CINC develops a clear definition of the desired end-state of the operation.

Table 1-1. Crisis Action Planning

SUMMARY OF TIME-SENSITIVE PLANNING PHASES

Phase I	Phase II	Phase III	Phase IV	Phase V	Phase VI
Situation Development	Crisis Assessment	Course of Action Development	Course of Action Selection	Execution Planning	Execution
Event					
<ul style="list-style-type: none"> ● Event occurs with possible national security implications 	CINC's Report/ Assessment received	CJCS publishes Warning Order	<ul style="list-style-type: none"> ● CJCS presents refined and prioritized COAs to NCA 	<ul style="list-style-type: none"> ● CINC receives Alert Order or Planning Order 	<ul style="list-style-type: none"> ● NCA decide to execute OPOD
Action					

<ul style="list-style-type: none"> ● Monitor world situation ● Recognize problem ● Submit CINC's assessment 	<ul style="list-style-type: none"> ● Increase awareness ● Increase reporting ● JCS assess situation ● JCS advise on possible military action ● NCA-CJCS evaluation 	<ul style="list-style-type: none"> ● Develop COAs ● Evaluate COAs ● Create, modify JOPEs data base ● CINC assigns tasks to subordinates by evaluation request message ● CINC reviews evaluation response messages ● USTRANSCOM prepares deployment estimates ● JCS review Commander's Estimate 	<ul style="list-style-type: none"> ● CJCS gives military advice to NCA ● CJCS may publish Planning Order to begin execution planning before formal selection of COA by NCA 	<ul style="list-style-type: none"> ● Adjust JOPES data base ● Identify movement requirements ● Identify and assign tasks to units ● Convert COA into OPORDs and supporting OPORDs ● Resolve shortfalls and limitations ● Begin SORTS ● Reporting ● JCS monitor OPORD development 	<ul style="list-style-type: none"> ● CJCS publishes Execute Order by authority and direction of SECDEF ● CINC executes OPORD ● JOPES data base maintained ● JPEC reports execution status
Outcome					
<ul style="list-style-type: none"> ● Assess that event may have national 	<ul style="list-style-type: none"> ● NCA/CJCS decide to develop military COA 	<ul style="list-style-type: none"> ● CINC publishes Commander's Estimate with recommended COA 	<ul style="list-style-type: none"> ● NCA select COA ● CJCS publishes COA selection by NCA in Alert Order 	<ul style="list-style-type: none"> ● CINC publishes OPORD 	<ul style="list-style-type: none"> ● Crisis resolved

1-44. The supported CINC and his service component commanders plan the correct mix of forces and proper arrival sequence in the theater of operations. During this stage, command, control, communications, and logistics relationships among the services of the joint force are finalized. The supported CINC determines the sequence in which Army units will deploy, in relation to the movement of forces of the other services, as early as possible since there is a finite amount of strategic lift available. This will solidify the TPFDD, determine the time required to deploy the force, and initialize the theater distribution plan.

1-45. Units deploy when they receive a movement directive. The movement directive identifies the units that will deploy, the order they will deploy, and how they will deploy. Prior to the movement directive, units may receive a warning order that allows them additional time to increase their deployment readiness and initiate crisis action activities.

FOUR-STEP PROCESS

1-46. The Army must train its organizations to configure and deploy tailored task forces rapidly. This four-step process involves: task organizing, echeloning, tailoring, and movement.

Task Organizing

1-47. This is the process of forming combined arms task forces, with limited self-sustainment capability, for rapid deployment. Task organizing, centered primarily around maneuver brigades, is a predeployment activity during normal training activities. Task organized units will develop close training relationships to facilitate deployment and tactical employment. Training at brigade level and above should include preparation for a variety of employment environments.

Echeloning

1-48. Echeloning is organizing units for movement. Like task organizing, echeloning is a predeployment SOP that establishes a priority for movement within the task force. Echelons may be divided, for example, into advanced parties, combat forces, follow-on forces, and closure forces. Within each echelon, there must be appropriate command, CS, and CSS elements. Planning for each echelon should include the number of vehicles and personnel and the consumable supply requirements. All Army units, regardless of echelon, will maintain detailed and accurate deployment data concerning air/sealift, weight/cube, and passenger manifests. Deployment data will include all required classes of supply and TOE or MTOE authorizations.

Tailoring

1-49. This occurs after METT-T, transportation, and pre-positioned assets have been identified. Where task organizing and echeloning are preplanned, tailoring is situationally dependent. Units may be added to or subtracted from a planned task organization based on the mission and available lift. Also, availability of pre-positioned equipment near the AO may allow for multiple echelons of personnel to be moved simultaneously to the operational area.

Movement

1-50. Units that are responding to a crisis must be able to assess their movement requirements quickly for USTRANSCOM to compute lift requirements and times of embarkation. Installation transportation and unit movement personnel must maintain proficiency on these systems and be prepared to update equipment lists on short notice. Commanders and movement personnel must ensure units are ready for movement on their movement directive. The USTRANSCOM issues the movement order for movement to the POE. The MTMC port call message is the movement order for units deploying by surface. The AMC issues an ATO via the ADANS for units deploying by air.

DEPLOYMENT COMMAND CHANNELS

1-51. Many civil and military organizations share the responsibilities for conducting deployment operations, beginning with the President, in his role as the CINC, and concluding with the military units that deploy. Deployment is a complex undertaking that requires constant and precise coordination among the planning and executing organizations. [FM 100-17](#) provides additional information on the responsibilities of national level authorities. The following paragraphs describe responsibilities of the JPEC. [Figure 1-5](#), shows deployment command channels.

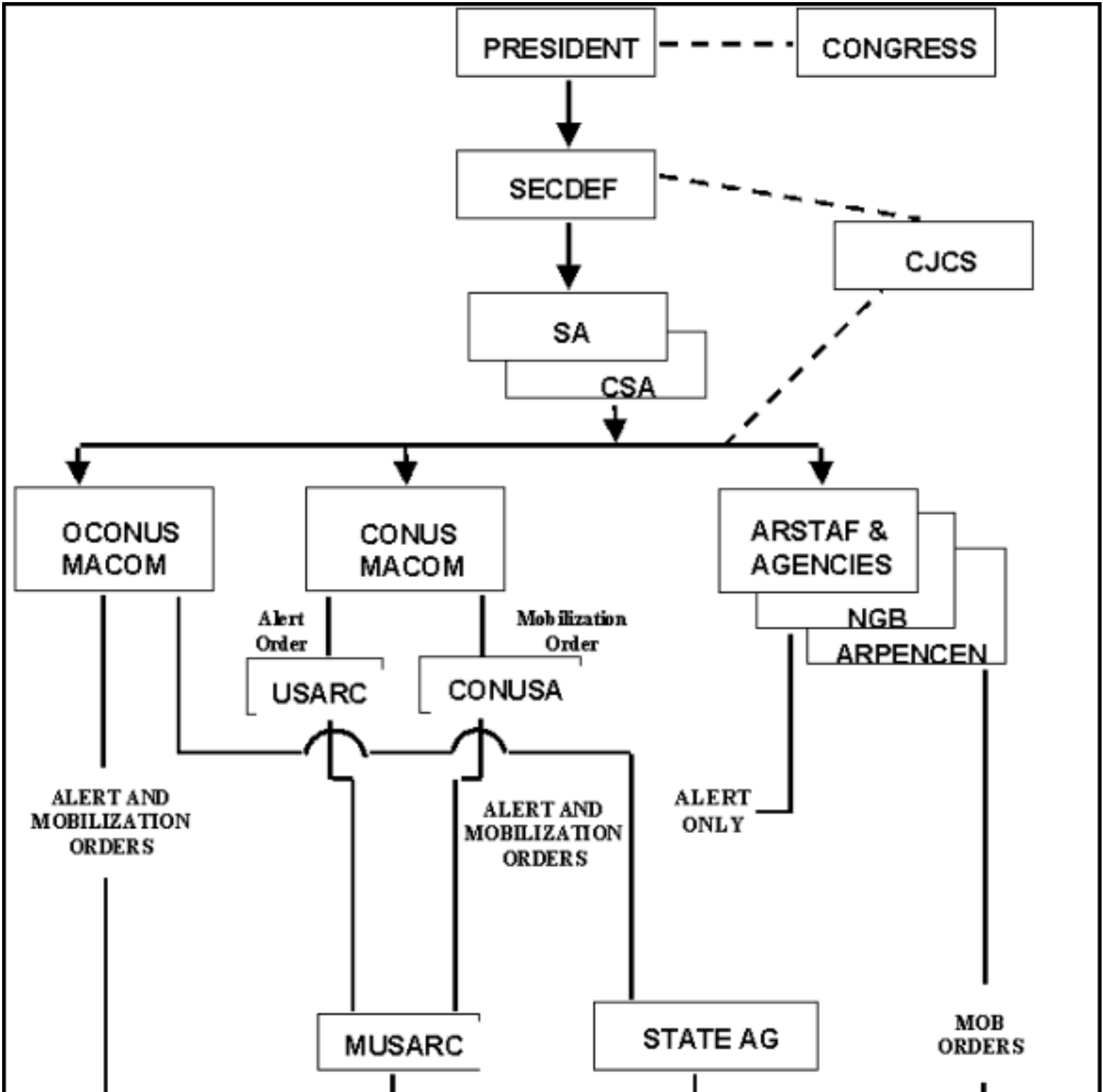

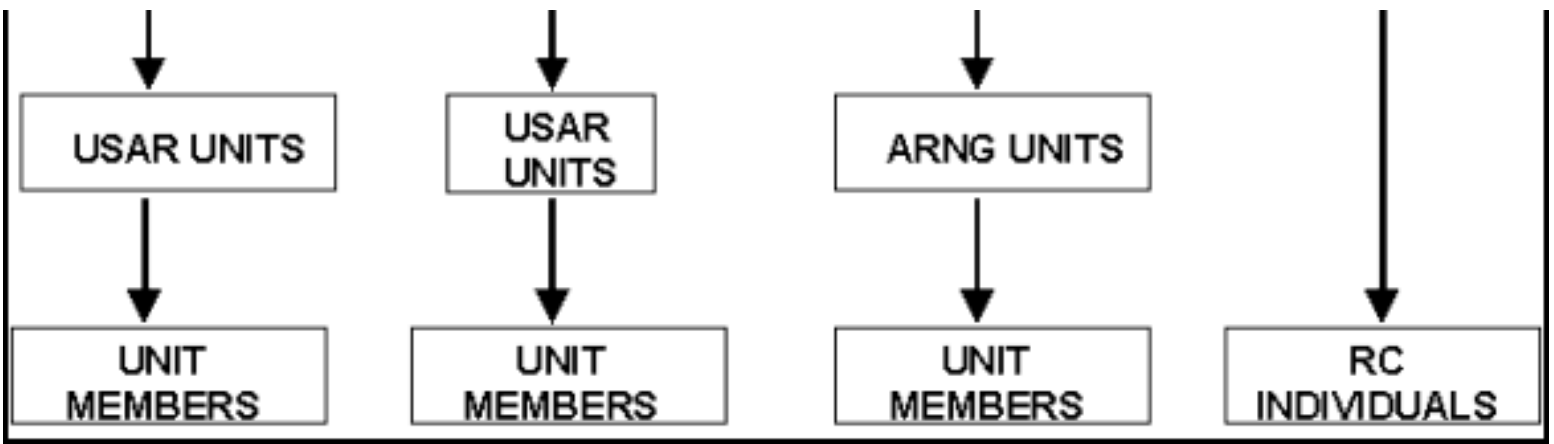

Figure 1-5. Deployment Command Channels

NATIONAL LEVEL

1-52. The President and SECDEF are referred to as the NCA. The NCA has the sole authority to order the deployment of military forces. The CJCS is the principal military advisor to the NCA. The NCA, specifically the SECDEF, assign forces to the combatant commands. The CJCS operates within the communications chain of command between the NCA and the combatant commanders.

1-53. The JCS provides the framework for deployment planning using the JSPS. Subject to the authority, direction, and control of the NCA, the CJCS performs the following:

- Provides strategic direction to the armed forces
- Prepares strategic and contingency plans.
- Advises in matters relating to requirements, programs, and budget.
- Develops joint doctrine, training, and education.
- Advises the NCA of military force requirements and apportions forces to the unified commands.
- Implements emergency actions to increase defense readiness condition.
- Provides deployment guidance.
- Allocates strategic lift.
- Monitors the mobilization and deployment process.

UNIFIED COMMANDERS

1-54. CINCs prepare operation plans in response to CJCS requirements. Operation plans are prepared in complete format (OPLANs) or in concept format (CONPLANs). OPLANs contain TFPDD, which is the JOPES data base portion of the plan. JOPES contains time-phased force data, non-unit related cargo and personnel data, and movement data for the OPLAN.

UNITED STATES TRANSPORTATION COMMAND

1-55. The major players in the movement of forces, equipment, and supplies are the USTRANSCOM and its transportation component commands--the MTMC, the MSC, and the AMC. The mission of USTRANSCOM is to provide strategic air, land, and sea transportation for the DOD in times of peace and war. USTRANSCOM is responsible for transportation aspects of worldwide mobility planning, operation of the JOPES, and centralized global transportation management. USTRANSCOM supports rapid execution planning, deployment, employment, and sustainment of US forces throughout the world. The command integrates transportation mobility and deployment automated systems into a single information system for all users through the GTN.

MILITARY TRAFFIC MANAGEMENT COMMAND

1-56. The mission of the MTMC is to meet military transportation needs in peace and war. MTMC designates SPOEs, prescribes when unit equipment must arrive at the SPOEs, and controls ship loading. It determines how DOD traffic is to move and what control is necessary to assure responsiveness to shipping units' requirements. Army and joint commands determines what is to move, where it is to move, and the priority for movement. MTMC manages CONUS freight and passenger traffic and Army passengers worldwide. It provides the interface between military shippers and civilian transportation industry, AMC, and MSC. As a transportation operator, MTMC operates ocean terminals throughout the world, with offices at water ports and seaports worldwide and the capability to operate additional ports as required using TTBdes from the RCs. Deployable cells from MTMC's active duty assets (named Tiger Teams) can open additional ports in 24 hours and operate until relieved by a TTBde in contingency situations.

MILITARY SEALIFT COMMAND

1-57. MSC is part of the operating forces of the US Navy. It is also the USTRANSCOM component command for waterborne common-user transportation operations. MSC provides strategic shipping and operates strategic sealift assets.

AIR MOBILITY COMMAND

1-58. AMC provides air transportation for DOD and other government agencies. As an Air Force major command under the direction of the CSAF, AMC organizes, trains, equips, and provides forces for worldwide strategic missions. AMC also plans, coordinates, and manages the CRAF program. When CRAF is activated, AMC assumes management of these assets. AMC's primary missions are airlift and aerial refueling. Its missions include the following:

- Airlift operational tasks (cargo airlift, passenger airlift, airdrop, aeromedical evacuation, and special operations).
- Aerial refueling operational tasks (SIOP, deployment, employment, redeployment, and special operations).
- Aerial deployment by means of airdrop and/or airland for deployment,

employment, and redeployment of forces and their support equipment.

- Logistical resupply of these forces.
- Aeromedical evacuation.
- Aerial refueling.

DEPARTMENT OF THE ARMY

1-59. DA is responsible for organizing, training, and equipping Army forces, to include the infrastructure to support strategic deployment. It prepares Army forces for commitment in support of national policy. These functions are executed under the supervision of the SA and the CSA.

ARMY SERVICE COMPONENT COMMANDS

1-60. Each unified command that has regional responsibilities has an ASCC. The ASCC may be forward stationed or CONUS based. The ASCC is responsible for the support of Army forces within the command. The ASCC either deploys Army forces to another ASCC in a supporting role or prepares to receive Army forces in a supported role. It develops the Army portion of the TPFDDs and supporting plans consistent with the unified commander's OPLAN. The ASCC are listed in [Table 1-2](#). The ASCC is responsible for the following:

- Protecting US property and interests in their AOs.
- Developing supporting plans for OPLANs.
- Training and preparing its assigned forces for deployment.
- Maintaining accurate UMD for its assigned units.
- Prescribing procedures, requirements, and responsibilities for deployment planning and execution.
- Coordinating deployment activities as scheduled by USTRANSCOM.
- Planning and preparing to receive and support forces if deployed to its AOs.

Table 1-2. Army Service Component Commands

UNIFIED COMMAND	ASCC
US European Command (USEUCOM)	US Army Europe (USAREUR)
US Pacific Command (USPACOM)	Army Pacific (USARPAC)
US Southern Command (USSOUTHCOM)	US Army South (USARSOUTH) Army Central (ARCENT)
US Central Command (USCENTCOM)	Army Forces Command (FORSCOM)
US Atlantic Command (USACOM)	

UNITED STATES ARMY FORCES COMMAND

1-61. FORSCOM is both a MACOM and the ASCC of USACOM. FORSCOM is the Army's CONUS executing agent for MDRD. It trains, mobilizes, and deploys combat-ready forces to meet operational commitments worldwide. FORSCOM provides planning guidance directives to the following:

- Other MACOMs and their installations.
- CONUSA.
- FORSCOM installations.
- Major troop units.
- NGB State AG.
- USARC.

1-62. Detailed guidance to the forces to accomplish this mission is explained in the FORMDEPS. The FORSCOM missions include the following:

- Protects the CONUS mobilization, deployment, and sustainment base through the LDC.
- Validates force requirements to support the OPLAN.
- Prepares Army forces for commitment in support of national policy.
- Maintains the DA Master File of standard UMD and standard unit movement reporting procedures for CONUS-based Army units.
- Prescribes procedures, requirements, and responsibilities for deployment planning and execution of FORMDEPS.
- Mobilizes, activates, trains, and supports RC units.
- Coordinates movement with and deploys forces as scheduled by USTRANSCOM.
- Coordinates deployment changes with the supported CINC and USTRANSCOM.

UNITED STATES ARMY TRAINING AND DOCTRINE COMMAND

1-63. TRADOC supports the execution of MDRD by expanding the mobilization training base (as required), by augmenting existing reception battalions and ATCs, and by establishing additional training centers. As the executive agent, TRADOC establishes and operates CRCs to prepare fillers and replacements for deployment. TRADOC coordinates with HQDA and FORSCOM for the call-up and release of assigned personnel and units.

UNITED STATES ARMY MATERIEL COMMAND

1-64. USAMC provides Army specific logistic support services and contract administration. USAMC supports the MDRD mission by augmenting its commodity commands and depot system to a level capable of supporting the force being mobilized

and deployed. USAMC may also be required to support the combatant commanders by providing contractor support and deploying military and key civilians to help on specific weapons systems or equipment.

THE NUMBERED ARMIES IN THE CONTINENTAL UNITED STATES

1-65. FORSCOM has assigned the CONUSA the responsibility for all planning, preparation, and execution of mobilization missions in their geographic area. These responsibilities include the following:

- Exercising OPCON over AC installations for mobilization and deployment planning and execution.
- Approval of all mobilization plans for MSs, MUSARCs, and STARCs.
- Acting as FORSCOM POC to other MACOM installations for matters concerning mobilization.
- Assessing MS capabilities to support mobilization execution.
- Command and control of mobilized RC units from the time they are mobilized at HS until arrival at the MS.

INSTALLATIONS AND AREA COMMANDS

1-66. For deployment operations, installations may be designated as MSs, CIs, SIs, or any combination of the above. During redeployment and demobilization operations, MSs are converted to DMSs.

1-67. The primary responsibilities of the MSs are to receive, house, command, support, cross-level assets, train, validate, and deploy mobilizing units and individuals. The CIs are designated POCs for off-post units and activities seeking to obtain necessary support. SIs provide the actual support to off-post units and activities. DMSs complete the out processing of units and individuals being separated or released from active duty and returning to reserve status.

1-68. ITOs provide guidance and help units prepare, maintain, and execute movement plans. They also coordinate and monitor unit movement, provide assistance to units in or traversing the installation support area, and coordinate commercial transportation support. They prepare movement reports, process convoy clearances and special hauling permits, and approve unit movement plans and associated data.

UNIT COMMANDERS

1-69. Unit commanders plan, train, and execute deployment. They establish mobilization and/or deployment as their first mission essential tasks. To deploy effectively, unit commanders must be knowledgeable about deployment processes and procedures.

[RDL](#)[Table of](#)[Document](#)[Download](#)[Homepage](#) [Contents](#) [Information](#) [Instructions](#)

Chapter 2

Strategic Mobility Automation Support Systems

The JPEC, and more specifically USTRANSCOM, obtains unit movement requirements from several systems. Unit movement requirements are compiled in an AUDEL. The JPEC uses AUDEL data to quantify deployment requirements for JOPES and theater specific movement requirements. This chapter identifies critical automated mobility systems and shows their interface with other automated systems in support of strategic deployment planning and execution. Since unit and individual deployment are essential to the conduct of war, this chapter will briefly identify critical personnel automated computer systems.

STRATEGIC PLANNING SYSTEMS

2-1. An overview of how to accomplish strategic deployment planning is needed to fully appreciate the complex processes involved. The systems used in developing strategic deployment plans are the WWMCCS and JOPES. The following paragraphs give a general description of WWMCCS and JOPES. Refer to [FM 100-17](#) for additional information on these systems.

WORLDWIDE MILITARY COMMAND AND CONTROL SYSTEM

2-2. WWMCCS provides the means for operational direction and technical administrative support needed to command and control US military forces. The system is comprised of the NMCS, the C4 systems of combatant commands, service component commands, DOD agencies, and WWMCCS-related management/information systems (see [Figure 2-1](#),). The system provides secure communications among those who make decisions. It also transmits their decisions to subordinates in the form of military orders.

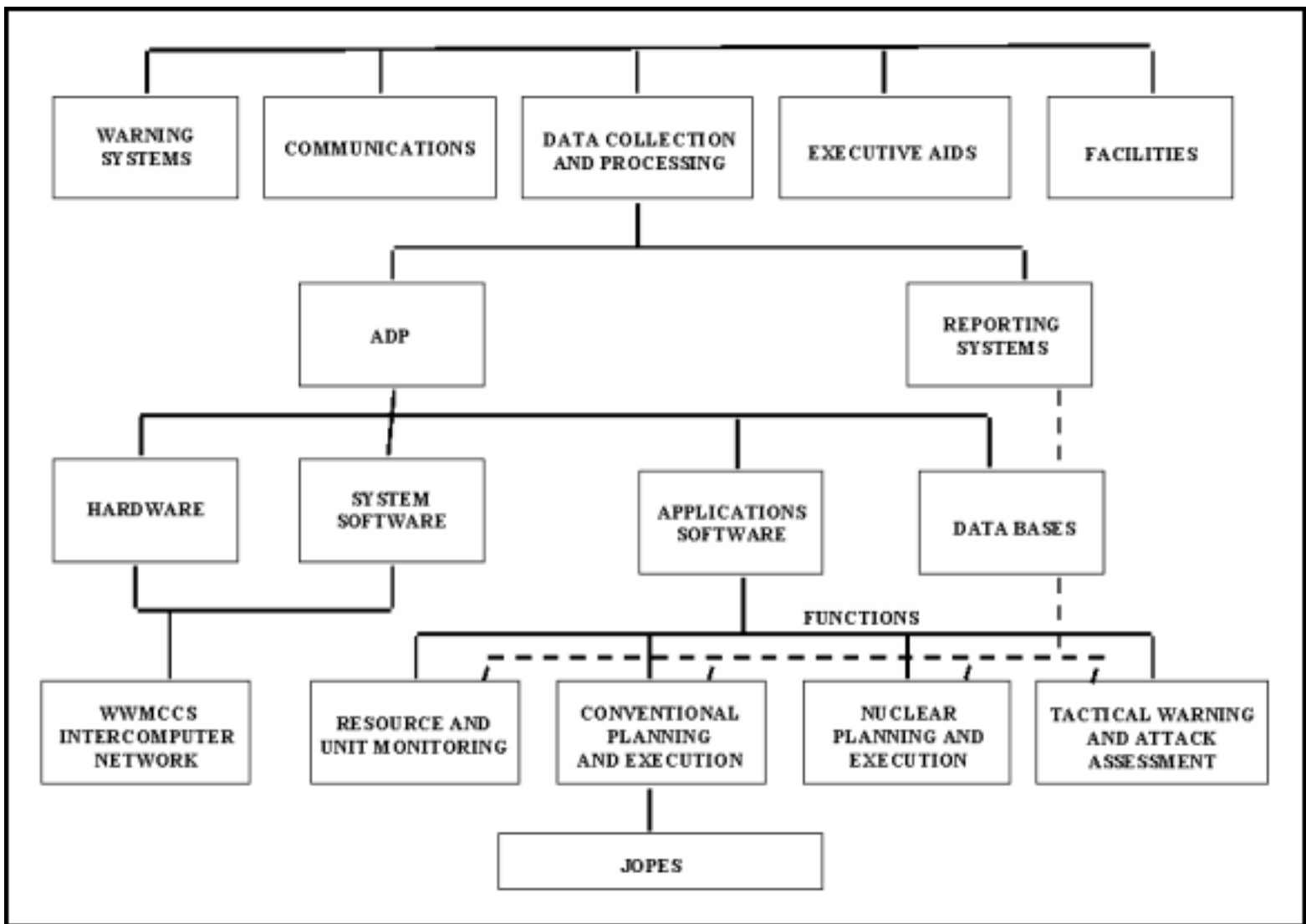

Figure 2-1. Elements of WWMCCS

2-3. WWMCCS encompasses many systems ranging from national to theater level. It interfaces with other systems such as the Presidential Command and Control Facilities, non-DOD systems, and tactical command and control systems that support subordinate military service units. With the WIN, users can communicate with other users, review and update data at other WWMCCS locations, and transfer data accurately and rapidly between commands.

JOINT OPERATIONS PLANNING AND EXECUTION SYSTEM

2-4. JOPES is the DOD system used to conduct joint planning and operations. It establishes an ordered and comprehensive set of procedures used in both deliberate planning and CAP of joint operations. It is oriented towards solving the complex strategic mobility problem associated with deploying and sustaining the force. JOPES is used by senior-level decision makers to plan and execute mobilization, monitor deployment, employment, sustainment, and redeployment activities. It supports the national, theater, and supporting organizational levels in both peacetime and in crisis (see [Figure 2-2](#)).

2-5. The JOPES has two end products (OPLANs and OPORDs). OPLANs are the result of deliberate planning conducted during peacetime. OPORDs are the result of crisis (time-sensitive) planning conducted in an emergency.

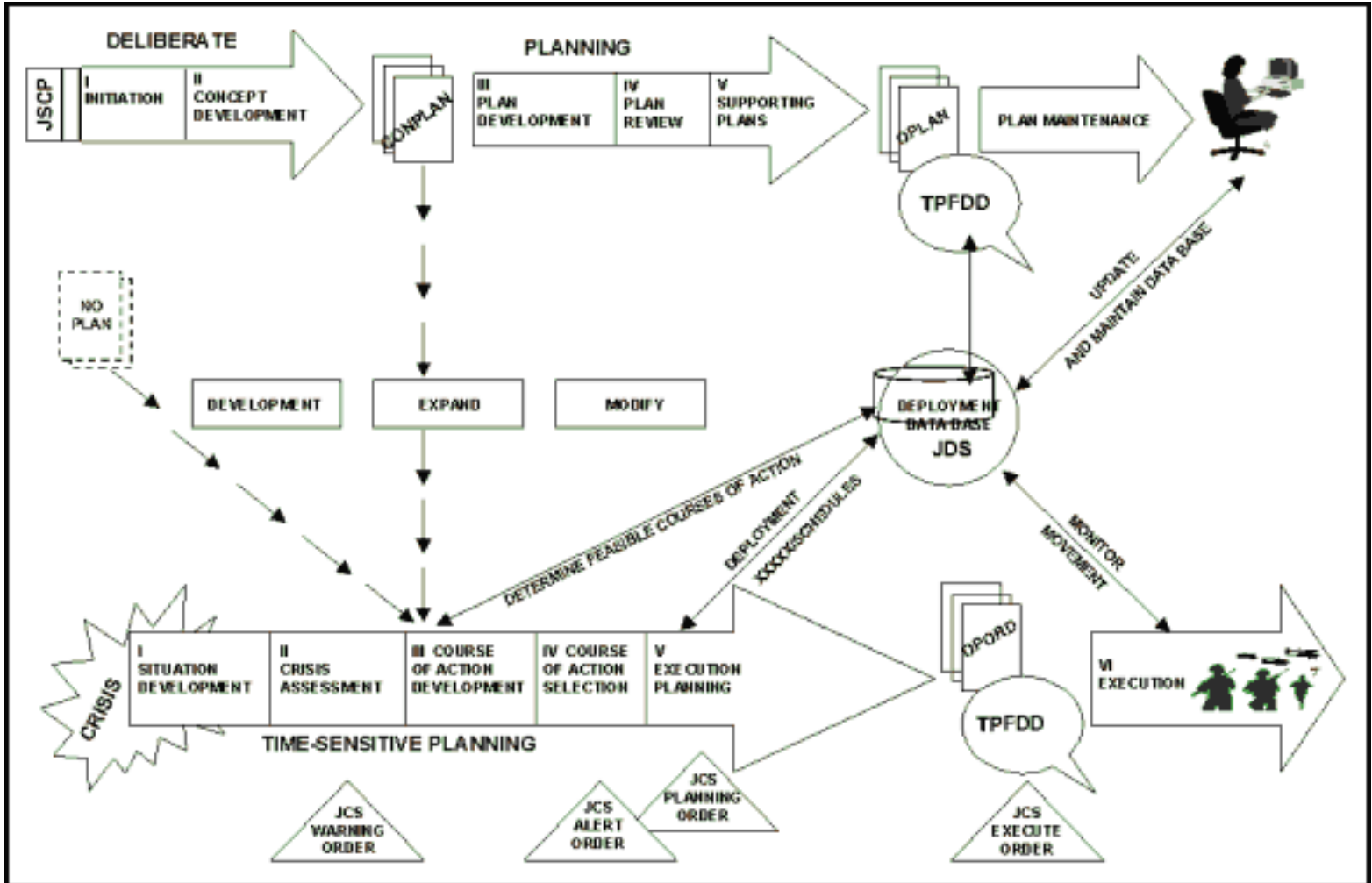

Figure 2-2. JOPES for Crisis Action

ARMY MOBILIZATION AND OPERATIONS PLANNING EXECUTION SYSTEM

2-6. AMOPES identifies active and reserve component major Army combat forces available to execute operational plans. It sets priorities for the apportionment of CS and CSS units (below-the-line units) in conjunction with the OPLANs. AMOPES provides mobilization and deployment definitions and guidance for planning and execution along with a detailed description of the Army's Crisis-Action System.

GLOBAL TRANSPORTATION NETWORK

2-7. USTRANSCOM's mission of global mobility management requires a responsive transportation system. The key to this is the development of the GTN. The GTN is not another transportation data base; it is a network of systems. It has been described as a capability integrating hardware, software, and communications system. The GTN ties

together existing transportation related data bases. It does not create a new data base. It gives the means to access C4 systems that support global transportation management. GTN systems can be divided into the following three functional categories:

- Systems required to support the planners as they gather the transportation requirements of the supported CINCs, develop operational plans, and evaluate the effectiveness of those plans.
- Systems for command and control that principally support mobilization and deployment.
- Systems that support ITV.

NOTE: ITV is the near real-time monitoring/tracking of unit and non-unit cargo and personnel from transportation origin to destination. This is the area in which USTRANSCOM has focused most of its efforts during the development of the demonstration prototype and the operational prototype.

TRANSPORTATION COORDINATOR-AUTOMATED INFORMATION FOR MOVEMENTS SYSTEM

2-8. DOD requires an automated capability to support rapid deployment of US forces and to furnish accurate and timely data to manage that deployment process. TC-AIMS is the generic term for the computer hardware, software, procedures, and other systems used by transportation coordinators throughout the services to automate planning, organizing, coordinating, and controlling unit deployment activities.

2-9. By performing activities common to both unit and non-unit movements with TC-AIMS equipment, commanders and movement personnel improve deployment proficiency. TC-AIMS offers timely and accurate information to the JPEC. The services are progressing with their unique system developments as follows:

- Army TC-ACCIS.
- Air Force COMPES.
- Marine Corps MDDS II.
- Navy TC-AIMS.

TRANSPORTATION COORDINATOR-AUTOMATED COMMAND AND CONTROL INFORMATION SYSTEM

2-10. TC-ACCIS is an information management and data communications system that Army units use to plan and execute deployments. TC-ACCIS speeds up the processing of mobility requirements and the flow of information to USTRANSCOM components. TC-ACCIS users include commanders, ITOs, UMCs, ICUMOs, DTO, brigade movement officers, and UMOs. [Figure 2-3](#), shows TC-ACCIS automation interface.

TC-ACCIS AUTOMATION INTERFACE

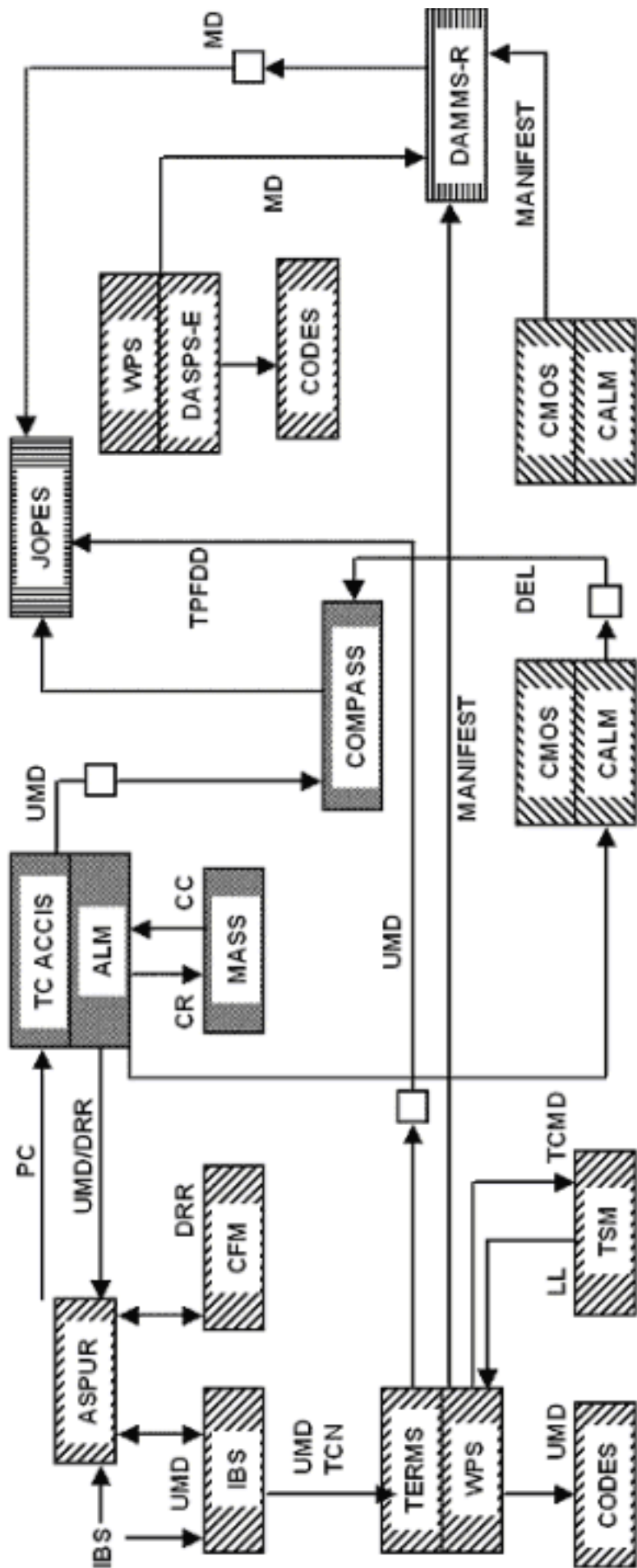

Automated Airload Planning Systems
 Automated Sys for Predetermining Unit Rqmts
 Computer Aided Load Manifest
 CONUS Freight Management
 Cargo Movements Operating System
 Computerized Deployment System
 Computerized Movement Planning - Status System

Department Army Movement Management System
 DA Standard Port System Enhanced
 Joint Operation Planning & Execution System
 MODCON Automated Support System
 M/TMTC Terminal Management System
 Worldwide Port System

() - Air Gap
 CR/CC - Convoy Request/Clearance
 DEL - Deploying Unit Equipment List
 DRR - Domestic Routing Request
 LL - Load List
 MD - Movement Data

PC - Port Call
 TC AD - Transportation Control Mov Doc
 TC 4 - Transportation Control Number
 TPFDD - Time Phased Force Deployment Data
 UMD - Unit Movement Date

AALPS -
 ASPOR -
 Calm -
 CFM -
 CMOS -
 CODES -
 COMPASS -

DAMMS -
 DASPS-E -
 JOPEs -
 MASS -
 TERMS -
 WPS -

	MTMC		FORSCOM/ MACOM		OTHER SERVICES		JCS		OCONUS
--	-------------	--	---------------------------	--	---------------------------	--	------------	--	---------------



Figure 2-3. TC-ACCIS Automation Interface

2-11. Army units operate TC-ACCIS on PCs and communicate with an installation central computer via modem or on terminals at the ITO. Units are responsible for maintaining accurate equipment lists.

2-12. TC-ACCIS software resides on computers at the ITOs of CONUS installations and ITOs or movement control units in overseas theaters. The computer performs all coordination, internal and external communication, and central data management functions. Access to information and communication between command levels follow the chain of command. The ITO, using the central computer, will consolidate requirements and transmit equipment lists and transportation requests to systems outside TC-ACCIS. For example, CONUS ITOs transmit data to FORSCOM's COMPASS data base. The MACOMs maintain UMD for joint operations planning.

2-13. Through TC-ACCIS, the ITO provides MTMC the deployment requirements, such as the DEL, domestic routing requests, export traffic release requests, and passenger transportation requirements. TC-ACCIS automates most transportation functions at the unit and installation level. Of particular importance to the unit's deployment mission are the following functions of TC-ACCIS:

- Maintaining unit equipment list.
- Maintaining deployment equipment list.
- Preparing GBLs.
- Preparing vehicle load card.
- Preparing vehicle/container packing list.
- Preparing advance TCMD (DD Form 1384).
- Preparing convoy march tables.
- Preparing DD Form 1266.
- Preparing DD Form 1265.
- Preparing unit equipment manifest.
- Preparing executable rail load plan.
- Preparing BBPCT material requirements list.
- Preparing rail load schedules.
- Interfacing with the ALM.

TC-ACCIS AIRLOAD MODULE

2-14. ALM, formerly the AALPS, is a computerized system used to produce air manifests containing all information required by the AMC. It is used by UMOs, deployment planners, and contingency planners/force designers to plan and execute air movement as well as design and analyze force packages. ALM operates with DEL data from TC-ACCIS or in a stand-alone configuration. ALM can do the following:

- Rapidly estimate airlift requirements for a given deployment list.
- Build, store, and maintain preplanned contingency packages.
- Provide automated assistance to produce individual aircraft load plans.

UNIT MOVEMENT OFFICER

2-15. The UMO prepares his unit's air movement plans for planned or actual deployment. ALM will automatically produce first-cut load plans and will provide computer assistance to modify those loads for execution.

DEPLOYMENT PLANNER

2-16. The deployment planner is usually the DTO or his equivalent. The DTO is responsible for determining airlift requirements for a planned or actual deployment. ALM supports deliberate planning by rapidly providing estimates of airlift requirements for a given deployment list.

CONTINGENCY PLANNER/FORCE DESIGNER

2-17. The contingency planner/force designer is usually the MACOM's primary transportation planner who is concerned with the impact of airlift requirements on a given contingency plan or force design. ALM permits building of predeveloped contingency packages and will determine airlift requirements for those packages for any delivery method and sortie configuration.

COMPUTER AIDED LOADING AND MANIFESTING SYSTEM

2-18. CALM is an Air Force designed automated system used to create individual air cargo manifest for AMC organic aircraft. It does not provide airlift requirements estimates or preplanned contingency packages. This system can be used by any service or organization.

COMPUTERIZED MOVEMENT PLANNING AND STATUS SYSTEM

2-19. COMPASS is a FORSCOM system that provides deployment planning systems with accurate Army unit movement requirements. Although COMPASS is not a property accountability system, it describes unit property and equipment in transportation terms. It converts UMD into a COMPASS AUDEL and maintains UMD for use in mobilization and deployment planning. This data originates from the UMD provided by Army units. The preferred system to transmit UMD to COMPASS is TC-ACCIS. However, manual systems, such as 900-R series cards, are still used. UMCs validate and transmit the data to FORSCOM COMPASS. COMPASS reformats the data and updates JOPEs. FORSCOM provides detailed guidance on how to prepare and submit UMD in [FORSCOM Regulation 55-2](#). [Figure 2-3](#) shows how COMPASS is integrated with deployment planning systems.

WORLDWIDE PORT SYSTEM

2-20. The WPS is a single Standard Terminal Documentation and Accountability System (see [Figures 2-4](#) and [2-5](#)). The WPS replaces TOLS, DASPS-E, TSM, DDN, and MAISRC. The WPS provides the following:

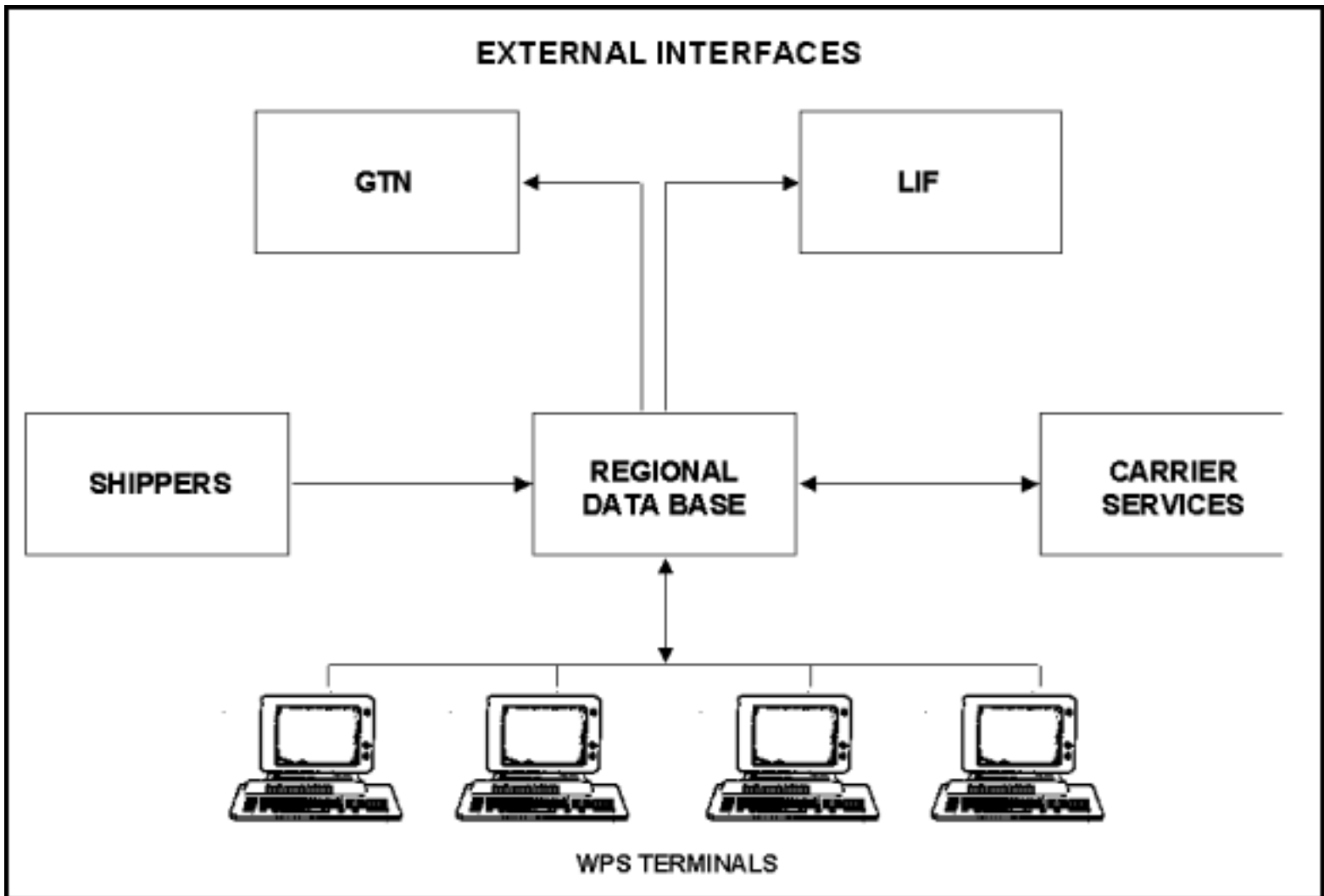

Figure 2-4. Worldwide Port System

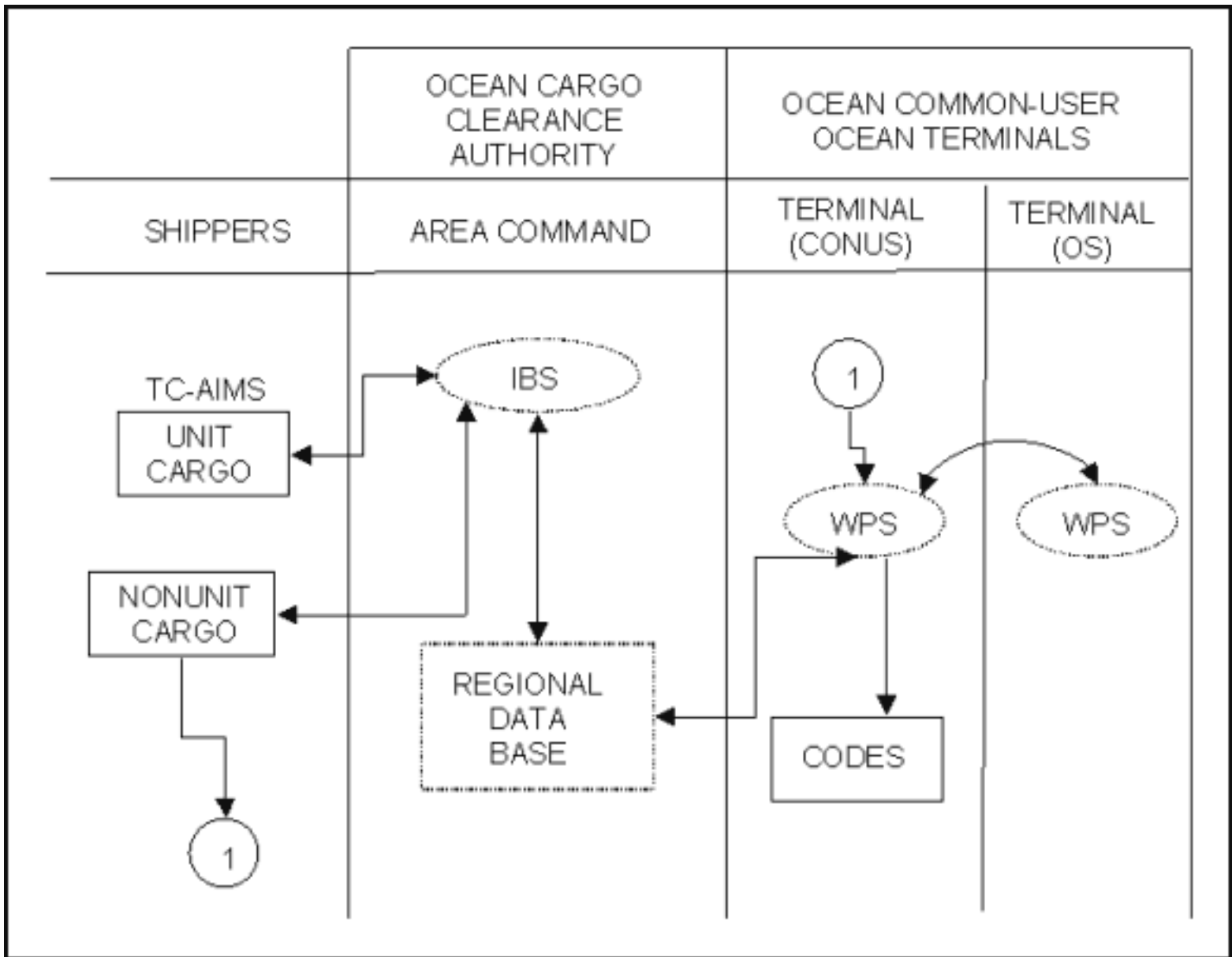

Figure 2-5. Ocean Cargo Clearance Authority

- Ocean terminals with the ability to document cargo moving through a port (manifests, TCMDs, and customs documentation).
- Ocean terminals with the ability to account for and monitor the movement of cargo through a port.
- Terminals and regional commanders the information necessary to manage the movement of ocean cargo.
- ITV information to other DOD systems.

IMPROVED COMPUTERIZED DEPLOYMENT SYSTEM

2-21. ICODES operates from a PC and provides load planning assistance to support deployment by vessel. ICODES main functions are to provide a computerized means of the following:

- Calculating trim and stability.

- Developing prestow plans and preparing final stowage plans for cargo loaded.
- Developing load diagrams.
- Tracking cargo placement.
- Prioritizing discharge of cargo.
- Developing railcar, container, and flatrack load plans.

NOTE: The accuracy of ICODES depends on the accuracy of the DEL. See [Figure 2-3](#) for interface.

AUTOMATED SYSTEM FOR PROCESSING UNIT REQUIREMENTS

2-22. ASPUR is an Intercomputer Data Communications Subsystem that interfaces between noncompatible automated movement systems. MTMC area commands use this system to process and transfer unit and non-unit movement files between connected systems. Used as an interface between installations and ports, ASPUR gives MTMC area commands the ability to process movement requirements for a crisis or for exercises. ASPUR communicates with connecting systems through DDN or DDD.

DEPARTMENT OF THE ARMY MOVEMENT MANAGEMENT SYSTEM-REDESIGN

2-23. DAMMS-R is the theater movement control system that will link to strategic systems to perform reception and onward movement tasks. The information is used by movement control units, mode operators, terminal operators, and materiel managers for planning receipt, discharge, storage, release, and onward movement of unit equipment and cargo. DAMMS-R also provides managers with the following:

- On-line computer terminals with the capability of entering transactions and producing reports.
- Automatic data calculations.
- Rapid and responsive information and report generation to satisfy transportation management needs.
- Standard, consistent, same-day reporting to theater movement managers of all transportation movements from point of origin to destination.

[Figure 2-6](#) shows the interface between DAMMS-R and strategic movement control systems. Refer to [FM 55-10](#) for additional information on theater movement control.

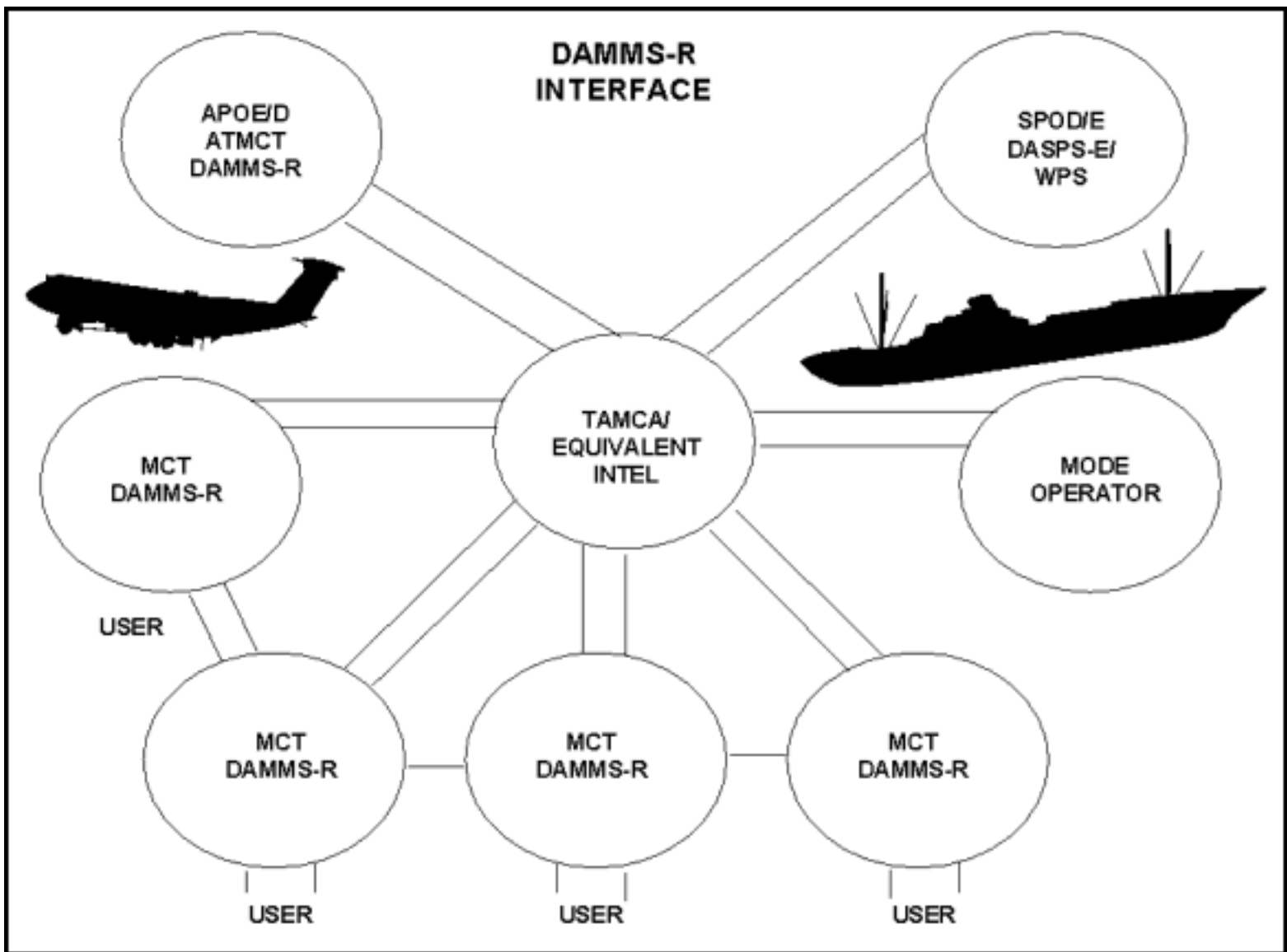

Figure 2-6. DAMMS-R Interface

UNIT MOVEMENT DATA TRANSACTIONS FOR CRISIS RESPONSE

2-24. When the CJCS issues a Warning Order, units will verify their UMD and the MACOM will update AUDEL data files. The deploying units tailor their AUDEL based on mission requirements, commander's guidance, and METT-T. The resulting tailored AUDEL becomes the DEL and prescribes which pieces of equipment and supplies will move. The deploying units must update their DEL with actual weights and dimensions and provide the movement requirements to the UMC in TC-ACCIS format. The UMC consolidates these DELs and sends them to FORSCOM and the MTMC area command via ASPUR which controls the deploying unit's SPOE. The MTMC area command uses this data to develop cargo manifests (WPS) and stow plans (ICODES) for the SPOEs. The SPOEs use these products from the DEL in making final preparations for vessel loading.

2-25. When CJCS issues the Execute Order, MACOMs issue a movement order, MTMC issues a port call message, and AMC issues an ATO. At the same time, MSC

notifies MTMC of the confirmed booking and vessel nomination. MTMC's area commands transmit the DEL to the SPOEs via ASPUR. The port operators at the SPOEs develop prestow plans and prepare to receive and load equipment. All data transmission will be done mainly via automation support systems.

2-26. AMC uses the GDSS to provide air movement messages to APOEs and to ALCSSs. The GDSS message includes air flow data for deploying units.

PERSONNEL DEPLOYMENT PLANNING SYSTEMS

2-27. During the stages of deployment, personnel managers must concentrate their efforts in the following four areas:

- Accessing mobilizing reserve component soldiers in the active component.
- Accounting for all assigned personnel.
- Reassigning nondeployable soldiers from deploying units and cross-level personnel.
- Providing theater fillers and replacements.

2-28. Two primary personnel automation systems (SIDPERS and ROAMS) are used to accomplish this mission.

STANDARD INSTALLATION DIVISION PERSONNEL SYSTEM

2-29. SIDPERS provides automated personnel service support for active and reserve Army soldiers. It supports strength accounting, personnel management, personnel actions, and exchange of information with other automated systems. SIDPERS provides commanders the ability to optimize allocation and use of personnel assets to meet peacetime, mobilization, and wartime personnel service support requirements.

2-30. SIDPERS, a STAMIS, operates on the TACCS. Also referred to as SIDPERS TACCS, it provides a standardized personnel system responsible for strength reporting and personnel administration. The main features of the system are data entry, ad hoc query, word processing, spread sheet, C2SRS (battle rosters, personnel requirements reports, personnel summary reports, and task force summary), and miscellaneous personnel functions.

REPLACEMENT OPERATIONS AUTOMATION MANAGEMENT SYSTEM

2-31. The PERSCOM provides theater fillers and replacements in support of CJCS OPLANs and is the HQDA executive agent for NRP distribution planning and execution. To accomplish this, automated procedures are developed and implemented to position filler and casualty replacements to the supported CINC.

2-32. The MOD, PERSCOM, assists the ASCC in projecting individual manpower requirements during OPLAN execution. Once executed, MOD is responsible for managing replacement flows to the theater and ensuring supported units are maintained at an acceptable personnel strength level. Currently, the following three

automated systems support this mission:

Automation of the Theater Shelf Requisitioning Process

2-33. AUTOREP generates fillers and casualty replacement requirements by personnel category, MOS, and grade and rank to predict the number of replacements required over time. Its product is known as the "Shelf Requisition."

NRP Flow Computer Assisted Program

2-34. FLOWCAP is used by PERSCOM and CRCs to schedule, control, and track the flow of replacements from the CRC to the theater. Applications also provide manifest data for AMC, advance arrival information for the ASCC, and generate internal reports for the CRC to manage and process replacements.

Automation of the Casualty Analysis Process

2-35. AUTOCAP compares actual casualty data and OPLAN modifications against projected and actual flow of casualty replacements and fillers. It also allows the ASCC to adjust projected requirements.

[RDL](#)[Table of](#)[Document](#)[Download](#)[Homepage](#) [Contents](#) [Information](#) [Instructions](#)

Chapter 3

Strategic Deployment Planning and Preparation at MACOM Level and Below

This chapter summarizes deployment planning and execution from a unit perspective. It focuses on the plans and preparations of deployment planning required at the various levels within the US Army. It also discusses the responsibilities of key players during planning.

LEVELS OF RESPONSIBILITY

3-1. The deployment planning and preparation process is a command responsibility that consists of three primary levels. These levels consist of the senior level (MACOM/ASCC), intermediate command level (UMC/ICUMO), and unit level (UMO).

SENIOR LEVEL

3-2. The senior level provides strategic guidance to units under its control for deployment planning and preparation. Army MACOMs and ASCCs perform the following:

- Establish policies and procedures for collecting, verifying, processing, maintaining, and submitting deployment planning data.
- Ensure the deployment readiness of subordinate commands.
- Coordinate deployment activities between units and the JPEC.

Alert Orders and Warning Orders

3-3. The CJCS Warning Order may be the first official indication that a unit may be directed to deploy. The Warning Order conveys the decision to prepare for deployment. The Warning Order passes from DA through the MACOM to the affected units. The Warning Order initiates specific unit actions and may require units to go to a higher level of deployment posture as shown below (active component only).

Deployability Posture	Action
-----------------------	--------

Normal	No action
Increased	Personnel recall
Advanced	Unit packed/positioned
Marshaled	Unit/transport moved to POE
Loaded	First increment loaded

MACOM Movement Directive

3-4. Based on the CJCS Warning Order, commanders alert units for deployment according to the OPORD. Deployment times are the result of strategic lift availability and the priority of the unit on the TPFDD. This priority dictates the date the unit is required in the theater. The movement directive provides resource funding guidance and identifies the unit movement category according to [AR 220-10](#). Unit movement categories are as follows:

Category	Definition
CAT A	Move all authorized equipment (property book).
CAT B	Move only mission-essential equipment (category for Army power projection).
CAT C	Move with less than mission-essential equipment.

USTRANSCOM Movement Directives

3-5. As the strategic lift manager, USTRANSCOM issues the movement directive to its components to schedule strategic lift according to the TPFDD. MTMC issues port call messages and AMC issues an air flow. The movement directive specifies when units must have their personnel and equipment at the POE. Intermediate and unit level commands conduct backward planning to accomplish all required deployment tasks and arrive at the POE as ordered.

INTERMEDIATE COMMAND LEVEL

3-6. The intermediate command level is normally an installation or area command. It consolidates regional/organizational deployment planning data and provides it to the senior level for validation and transmission to JOPES. The intermediate command level authority is the unit's contact for deployment transportation support and instructions. The ICUMO helps units develop and execute unit movement plans.

Unit Movement Coordinator

3-7. Within CONUS, the installation UMC coordinates strategic movements and provides valuable movement information on the development of practical movement plans. The UMC is usually a part of the ITO's staff. The UMC is the primary

intermediate level agent and a key deployment player. The UMC performs the following:

- Serves as the regional/organizational POC between the deployable unit, MACOM, and USTRANSCOM for receipt and submission of UMD.
- Ensures subordinate and supported units update UMD and commanders verify data accuracy.
- Coordinates and maintains unit plans for movement of cargo and personnel by all modes.
- Ensures unit movement plans are compatible with regional/organizational capabilities.
- Coordinates unit escort (supercargo and rail guard) requirements.
- Submits unit deployment planning data to the senior level.
- Maintains data on external military and commercial requirements (including type of railcars, commercial trucks, and buses) and preplans support to move units to the POE.
- Coordinates convoy clearances and special hauling permits for unit requirements.
- Ensures the unit complies with HAZMAT restrictions ([CFR 49](#), [AFJM 24-204](#), [AR 55-355](#) and IMDG Code).
- Coordinates unit requirements for issue and receipt of military 463L pallets and shipping containers.
- Coordinates movement order equipment restrictions and/or peculiarities on specific strategic lift assets.
- Assists units to tailor the AUDEL and update the UMD to create a DEL during crisis action.
- Coordinates commercial transportation according to routing instructions received from USTRANSCOM.
- Provides technical assistance to units at loading and unloading sites.
- Notifies deploying units of the movement schedules.
- Provides unit movement information to their operations staff counterpart for developing/submitting movement reports.
- Helps units to identify and obtain materials for unit deployments.
- Monitors the status of military shipping containers in the regional organizational AOR.
- Helps unit and ICUMOs develop deployment training.
- Helps units process through POEs as required.
- Provides like support to mobilized RC units for movement to MSs ([AR 5-9](#)).

Deployment Support Brigades

3-8. DSBs are RC MTMC units that assist the UMC and deploying units with documenting, staging, and loading their equipment. DSBs provide liaison between the installation and the POE to coordinate the technical aspects of preparation of equipment. A DSB consists of 10 or more UMTs. Each UMT may consist of six persons. A DSB HQ establishes operations with its MTMC area command HQ. The MTMC area operation center directs the DSB's UMTs to various installations. The UMTs will assist the ICUMO/UMC of these installations with specific deployment activities. DSBs will perform the following:

- Establish and provide liaison between the port command and the ICUMO/UMC.
- Coordinate movement schedules, documentation, special cargo handling requirements, including heavy lift, hazardous, sensitive, non-standard configuration equipment, and any other information needed with the port command.
- Assist the ICUMO/UMC in reviewing AUELs/DELS, movement plans, rail and truck loading plans, staging plans, and other documentation.
- Provide guidance to unit movement personnel to verify accuracy of movement documents and to show any missing or damaged equipment.
- Provide guidance to the deploying unit on preparing equipment and cargo loads for strategic movement.
- Ensure deploying units are marshalled and loaded in compliance with appropriate Federal, State, local, and HN environmental laws.
- Inspect equipment to ensure that vehicles are correctly identified, cargo is properly loaded on the vehicles, and no equipment is missing that would impair the loading operations at the port.
- Monitor the loading activity and assist in inspecting military or commercial carrier vehicles.
- Provide guidance in hazardous cargo preparation and certification.
- Provide advice in BBPCT.

UNIT LEVEL

3-9. The unit level is the basic and most critical level. All Army units must be prepared to deploy and be trained in deployment skills. Personnel assigned unit movement responsibilities must be fully trained and qualified for the positions they hold. The UMO will perform the following:

- Prepares and maintains unit movement plans.
- Prepares and maintains the AUEL and other documentation needed for unit movements.
- Changes and submits UMD as required by MACOM/ASCC.
- Supervises the preparation and execution of unit load plans.
- Coordinates with higher HQ and support activities on unit movements.

- Coordinates logistical support for the move.
- Maintains on file, approved copies of all unit load plans.
- Establishes and trains unit loading team.
- Ensures the unit has access to personnel who are authorized to certify HAZMATs.

3-10. Unit commanders routinely review and update movement plans and SOPs. They make sure that the movement plans and SOPs are consistent with OPLANs. The commander may also direct the planning to support newly activated units or newly assigned OPLANs. The unit commander also appoints a UMO and ensures that the UMO is trained. Commanders should strive to appoint UMOs who have some retainability in the unit.

3-11. Commanders appoint officers and/or senior NCOs as UMOs to help them prepare the unit for movement. The UMO must know and execute the commander's intent when developing and updating movement plans. The UMO must make sure that the movement plan is current and reflects changes in personnel and equipment as they occur. The UMO also maintains liaison with higher HQ and support activities on matters concerning unit movement. In the absence of the commander, the UMO represents the unit commander on deployment matters. [Appendix A](#) describes the UMO's training requirements. Commanders ensure that each member of the unit knows his responsibilities during deployment.

Unit Movement Plans

3-12. The unit uses movement plans to successfully organize, coordinate, and execute a unit move. Movement plans are written in a five-paragraph OPLAN format. They may contain SOPs, AUEs, and other annexes as directed. Movement plans are working documents at unit level and should not contain classified material. The unit requires a unit movement plan for each type of move. Unit movement plans define specific responsibilities, functions, and details for each part of a unit move from origin to POE. An effective movement plan contains preparation steps required to deploy. The plan requires considerable coordination and support from all levels in the chain of command. It should incorporate lessons learned from previous moves and exercises that test the plan. The four types of unit movement plans are mobilization, deployment, exercise, and change of station. ASCC and MACOMs establish formats for movement plans. A sample unit movement plan is contained in [FM 55-15](#). The unit commander, intermediate level authority, and UMO will check the unit movement plans to make sure that the following requirements are met:

- Sufficient local implementing guidance on vehicle load plan development and testing have been developed.
- Vehicle load plans have been prepared for all cargo-carrying vehicles.
- Vehicle load plans include provisions for all organizational equipment and supplies to be moved on unit vehicles.
- Supplemental transportation requirements have been identified, such as

commercial lift and other military units.

- Arrangements have been made for needed supplemental transportation and movement of hazardous cargo.
- Provisions have been made for necessary packing materials and shipping containers.
- All aspects of unit movement plans have been tested and updated, as needed.

Unit Movement SOP

3-13. The unit movement SOP outlines functions that should occur automatically upon notification of a unit movement. It should be generic to fit any given situation. It should outline day-to-day as well as alert functions. The SOP defines the duties of each section that will bring the unit to a higher state of readiness. These functions may include but are not limited to unit property disposition, supply draw, equipment maintenance, vehicle and container loading, security, marshaling procedures, purchasing authorities, and unit briefings. The commander must review unit SOPs on a regular basis and distribute them to each concerned position and section within the unit. Command emphasis and training are the most effective means of ensuring a proper state of readiness within the unit.

Unit Movement Binders/Mobilization Files

3-14. In addition to the movement SOP, units should prepare movement binders for quick reference. Movement binders should contain the following:

- Appointment orders including instructions for the UMO, unit movement NCO, load teams, purchasing authority, and personnel who are school trained or otherwise qualified to certify hazardous cargo and air load plans.
- An alert roster with instructions.
- A list of major equipment shortage items.
- A list of blocking, bracing, and packing materials, coordination requirements, and prepared requisitions.
- A list of supplies by support activity, coordination requirements (lists of personnel, transporting locations, and MHE), and prepared requisitions.
- Coordination requirements for executing the move (lists of nonorganic equipment, mess support, and explosive meters) and a list of supporting agencies, personnel (by position title) and telephone number.
- Instructions for other actions unique to the organization.
- Examples of forms required for personnel support during deployment, such as AG, JAG, and medical.
- A list of pertinent references.
- Rear detachment and family support group operations.
- An AUDEL.

- Transportation requirements for each mode. The UMO and the ICUMO will determine the need to transport cargo. The ICUMO will plan for nonorganic transport of cargo and show this requirement on the unit AUDEL report. Locations for spotting trucks and for acquiring MHE must be documented and entered in the unit movement plans.
- Convoy clearance requests. The appropriate form for the area where the unit is stationed will be prepared in advance if the unit is required to conduct a road march from the installation to the SPOE.
- Special hauling permit requests. The appropriate form for the area where the unit is stationed will be prepared in advance for the movement of oversize, overweight, and other vehicles requiring special considerations over public highways.
- Strip maps for each route of march, including alternate routes.
- A spill contingency plan including emergency supplies and equipment for isolating and disposing of HAZMAT spills.

Battle Book

3-15. The battle book is a comprehensive planning document that the unit commander may use to accomplish the unit's movement in a specific theater of operations. The battle book is classified according to [AR 380-5](#). The battle book includes the following:

- The unit's mission.
- The organization, staffing, and actions required to achieve a mission ready posture.
- A copy of pertinent information from the OPLAN or the TPFDL.
- The Army Reserve Stock material appendix and listing and the Army Reserve draw team SOP, if applicable to the unit mission. FM 100-17-1 provides additional information on AR-3, Pre-positioned Afloat.
- The photographs and maps appendix. If possible, this appendix will include the following:
 - Maps of all convoy routes and AOs.
 - Photographs of all critical areas the unit will pass through en route to its destination. Photographs will include the APOD, the SPOD, the Army Reserve draw site, convoy routes, and critical points.
- An operations appendix. This appendix will include the following:
 - A description of operating facilities including maps, diagrams, and photographs keyed to the unit operations site in the theater area.
 - Operational data and procedures.
 - Specific supporting and support organizations with which the unit must interface.
- Army Reserve Stock advance party for battalion and company size

organizations ([Table 3-1](#)).

**Table 3-1. Composition of Army Reserve Advance Party
(Battalion and Company Size)**

Selections/Teams	Battalion			Company		
	Officer	NCO	Enlisted Men	Officer	NCO	Enlisted Men
Command Section	1	1	0	1	1	0
PBO/Hand Receipt Holder	1	1	0	1	1	0
Battery Activation	0	1	15	0	1	4
Battery Installation	0	2	20	0	2	8
Fueling	0	2	8	0	2	4
Maintenance	0	1	8	0	1	3
Auxiliary Equipment	0	6*	16	0	6*	16
Vehicle-Mounted Equipment	0	1	4	0	1	4
Trailers	0	1	5	0	1	2
Drivers per battalion- and company-size: 1 per prime mover 1 NCO per 10 operators						
One NCO as NCOIC						
NOTE: Advance party normally consists of 25 percent to 30 percent assigned personnel.						

MOVEMENT PLANNING PROCESS

3-16. The following information will help units develop their movement plans. Some units may have unique transportability problems. These problems may not surface until the units are deployed or the movement plans tested. The intermediate level authority will assist in preparing plans.

3-17. The TPFDD and the OPLAN will define transportation modes for movement to

the POD. Operations staffs should provide units planning guidelines based on anticipated OPLANs.

3-18. In an overseas deployment, unit equipment is sent by sea two or three weeks before unit main body personnel depart for the AO (if unit personnel are traveling by air). Based on the unit's proximity to the POE, the availability of railcars and commercial trucks, and the type of unit equipment, the unit may move to the POE by unit convoy, rail, commercial truck, or a combination of all three.

3-19. Normally, unit personnel will travel by air accompanied by yellow TAT equipment. The flow of personnel should be in sequence with the arrival of unit equipment at the SPOD. See [Chapter 4](#) for specific guidance on movement by air.

PERSONNEL STRENGTH ANALYSIS

3-20. For planning purposes, the unit commander uses the required strength of the unit according to the MTOE. The commander must plan the breakdown of personnel for Army Reserve draw teams, supercargoes, and the advance party. The commander will determine personnel transportation requirements and the basic loads of supplies initially required by the unit to sustain operations upon arrival in the theater of operations.

EQUIPMENT ANALYSIS

3-21. In conducting a unit equipment analysis, the commander must review the unit's TOE, MTOE, CTA, and AC/RC material standing, if appropriate. The commander must review the AUDEL to determine what will be moved based on METT-T. All outsize, oversize, or overweight pieces of equipment must be identified as they will require special handling. Units should deploy with their STAMIS.

SUPPLY ANALYSIS

3-22. The commander should identify research required items in each class of supply that the unit will need for a deployment. Requisitions should be prepared in advance for each item required. Personnel must maintain a record of the following data:

- A completed [DA Form 2765-1](#) for each item not already on hand. This information can sometimes be obtained from the unit's PLL and the ASL.
- The telephone number and POCs for each supply source.

Changes in requisition priorities may cause equipment to be received during the deployment process. Units must be prepared to accept and process this equipment for deployment. This may require changes to the AUDEL. Upon deployment notification, the unit will follow up outstanding requisitions and update addresses. The OPLAN/OPORD may dictate variations of stockage requirements and supplies that will accompany the unit based on METT-T. However, full MTOE deployments will include the following items:

- **Class I (subsistence).** Units should plan for five days of operational rations (or the amount specified in applicable OPLANs/OPORDs for each person moving to the AOs, supercargoes and guards, and the advance party).
- **Classes II and IV (individual equipment and construction materials).** These items include a basic load of clothing and individual equipment (see [CTA 50-900](#)). Equipment and construction materials also will include the following:
 - Enough sandbags for hardening vehicles and for the troop billeting areas as well as the unit's combat requirements.
 - BBPCT material.
 - Concertina/razor wire.
 - Paint for stenciling.
 - Shipping containers for unit equipment and supplies. Containers should be considered for redeployment requirements.
 - Cleaning equipment, such as long-handled brushes for vehicles.
 - Field sanitation equipment ([FM 21-10](#).)
- **Class III (petroleum, oils, and lubricants).** Units should plan for a 15 day supply of packaged POL.
- **Class V (basic load of ammunition).** A [DA Form 581](#) will be included in the movement plans.
- **Class VI (personal demand items).** Personnel should bring a 30 day supply of personal demand items.
- **Class VII (major end items).** Critical equipment shortages are identified according to [AR 220-1](#). The receipt of this filler equipment upon deployment should be calculated in all planning phases.
- **Class VIII (medical supplies).** Medical supplies authorized for units are listed in [CTA 8-100](#). Authorization for biological and chemical agent medical materials is in [AR 40-61](#), [AR 710-2](#), and [AR 40-562](#).
- **Class IX (repair parts).** Units will keep a 15 day PLL in the unit at all times. Space and weight must be planned.
- **Expendable supplies.** Units should plan for a 15 day supply of items. Requisitions for those items that must be kept on hand include the following:
 - SSSC items.
 - Convoy flags.
 - Fuel tank purging equipment.
 - A 90 day supply of forms.
 - Required publications.

NOTE: Units drawing Army Reserve stocks may be limited to the type and amount of accompanying supplies.

ACCOMPANYING SUPPLIES AND EQUIPMENT

3-23. UMOs should review the TOE, MTOE, CTA equipment, and the supply list to determine which supplies and equipment will accompany troops and how they will accompany troops. The amount of TAT equipment that a unit can ship is based on available lift. The amount of TAT equipment that a unit should ship is based on the mission and available support at destination. The three categories are yellow TAT, red TAT, and NTAT.

3-24. Yellow TAT is equipment that must accompany troops and be accessible en route. Examples include the following:

- Records of unit property and personnel.
- Basic load of Class I items.
- Basic load of Class V small arms items and individual weapons.
- Individual carry-on baggage.
- Administrative equipment needed immediately upon arrival, such as laptop computers and communications equipment.

3-25. Red TAT equipment must be available at the overseas destination before or upon the arrival of the unit. The amount of red TAT equipment that a unit can ship is based on available lift. Red TAT equipment may be sensitive cargo that requires special security or handling at the SPOE or SPOD. It may include cargo to be loaded last on and first off. Examples include the following:

- Individual baggage.
- Tents.
- Basic loads of supplies.
- Tool boxes.
- Crew-served weapons.
- Administrative equipment, such as typewriters, field desks, and field safes.

3-26. NTAT equipment is normally shipped by surface and does not accompany the troops. It consists of all other equipment required for the unit to perform its mission.

PACKING AND LOADING

3-27. Planning to pack and load unit equipment for movement is an important unit responsibility. The UMO identifies the actual space, weight, packaging material, and external transport requirements needed for deployment. If done properly, this planning will save the unit time and prevent delays. Units should rehearse packing and loading procedures.

3-28. Unit personnel consolidate all TOE, MTOE, CTA equipment, and basic loads of supplies at loading sites. They ensure that all required packing material, supplies, and MHE are staged. The UMO will assemble and brief all appropriate unit personnel on

the following packing and loading requirements:

- Packing lists.
- Load diagrams.
- Container stuffing.
- Banding, blocking, and bracing procedures.
- Vehicle preparation and loading techniques (see [Appendix C](#)).
- HAZMAT procedures (segregating, documenting and packing) (see [Appendix D](#)).
- Dimension and weight rules.

The unit should determine which supplies and equipment will be packed or loaded in unit vehicles. The unit should consider special planning for equipment passing directly into or through a hostile area en route to its destination. Materials, such as empty sandbags used for hardening the vehicle, must be packed inside vehicles if the unit will be passing through a hostile area after departing the SPOD. Convoy flags and signs must be placed on vehicles where they can easily be seen or where they are readily accessible at the SPOD. The following are considerations for packing and loading unit equipment:

- Allow adequate time to properly assemble, pack, load, and document equipment.
- Obtain/contract, order, and pre-position BBPCT material. Coordinate with installation activities, such as with the DPW for the construction of crates and blocking and bracing materials. Coordinate with the DOL for the acquisition of inserts, boxes, pallets, and other containers.
- Request appropriate MHE support, such as forklifts and cranes.
- Coordinate for planning and technical assistance, including information on any special packing and marking requirements.
- Coordinate for temporary use of shortage items identified during the equipment and supply analyses.
- Prepare packing site(s) and ensure there is enough room for forklifts, cranes, and trucks to maneuver.
- Obtain/contract scales.
- Obtain stenciling materials.
- Obtain required documentation such as [DA Form 5748-R](#) and [DD Form 1387](#).

NOTE: See [Appendix A](#) for documentation.

Vehicle Loads

3-29. The unit should secure secondary cargo in its organic vehicles. Cargo should be securely restrained with chains and binders, rope, straps, and/or wire rope to prevent movement in any direction to ensure there is no metal-to-metal contact for loaded

of the tie-down assemblies used to secure cargo from movement must be at least 1 1/2 times the weight of the cargo. Pipes, lumber, 55-gallon drums, or other large cylindrical containers are lashed with chain, 1-inch steel bands, or wire. Do not cover 55-gallon drums and 5-gallon cans. Banded or boxed cargo that weighs more than 2,000 pounds and handled as a single unit will be secured as follows:

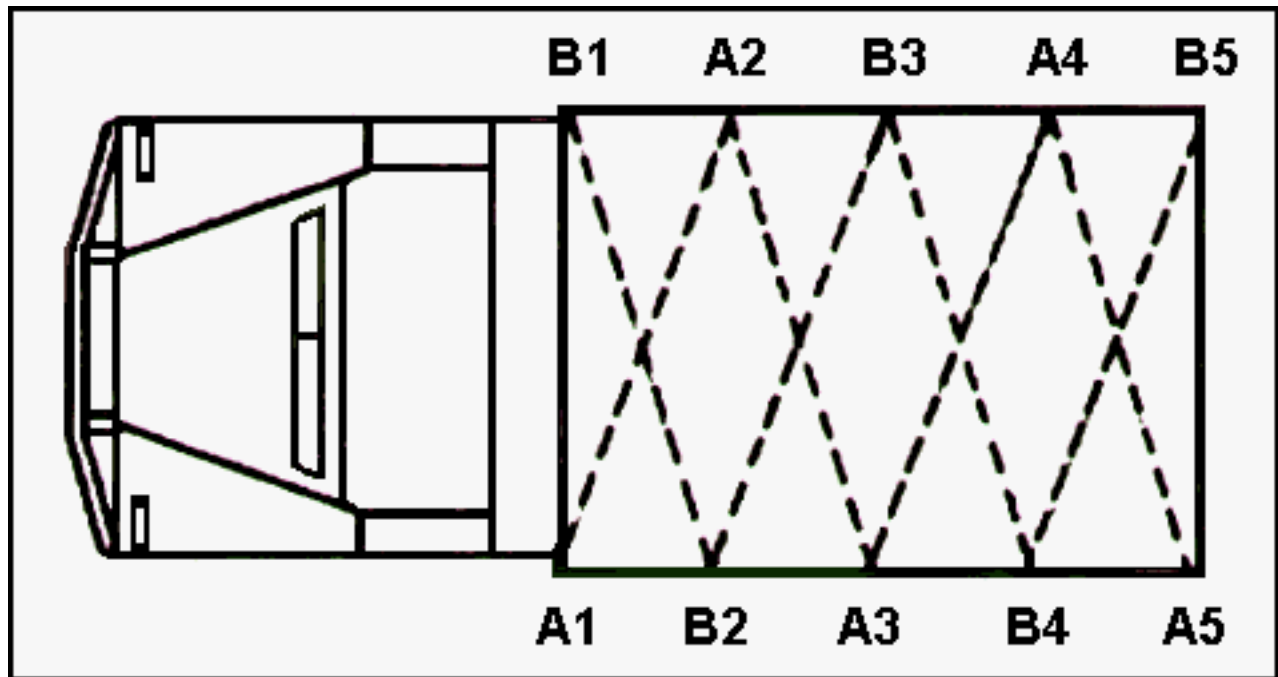

Figure 3-2. Lashing Procedure on a 2 1/2-Ton Truck

- Place one tie-down assembly every 8 feet over the top of the cargo.
- Place 4- x 4-inch cross sections of timber across the top of cargo that is 8 feet long or less. Secure the cargo with tie-down assemblies.
- Cover equipment stored in cargo beds with canvas. Coverage will protect cargo against weather during shipment and help prevent pilferage. (The canvas can be secured under the rope used to restrain the cargo. The rope must be the primary material used to restrain the cargo, not the canvas.)

NOTE: Before moving the vehicle, inspect the load to ensure that it is properly lashed so that it will not shift or fall off in transit. Cover the truck with a tarpaulin if the cargo needs to be protected from the weather.

Equipment Weights and Dimensions

3-34. The UMO must ensure the AUDEL reflects the actual weight and dimensions of each separate load of cargo. During deployments or exercises, as load plans change, the UMO should update the AUDEL with these changes.

- **Weights.** Weight must not exceed the vehicles' payload capacity. The only way to obtain an accurate weight for vehicles, containers, or equipment is to use scales. Units that do not have access to vehicle scales must coordinate with their ITO or higher HQ for assistance. The vehicle will encounter some stress while in transit, such as when railcars are coupling or uncoupling, when a ship

encounters rough seas, when an aircraft experiences turbulence while in flight, or when a jolt occurs while landing. The stress is particularly felt where the cargo bed is attached to the vehicle frame. Through a series of jolts, an overloaded vehicle could sustain structural damage that may result in a nonoperational vehicle. Therefore, while weighing vehicles, personnel may have to redistribute the cargo. Once the organic vehicles have been fully loaded, remaining unit equipment will be containerized (see [Appendix E](#)).

- **Dimensions.** Reporting accurate dimensions is essential for deployment. The difference in inches could mean the difference between that piece of equipment clearing a highway overpass, clearing a highway or railroad tunnel, or fitting into an aircraft or the deck of a ship. The UMO must ensure that the AUEL reflects actual dimensions. The UMO selects the correct LIN in [TB 55-46-1/TB 55-46-2](#) for standard vehicles or enters actual dimensions for nonstandard vehicles. The ITO or ICUMO provides technical assistance to UMOs to determine if the unit has vehicles with dimensions that may have clearance problems during transport. Unit personnel should measure vehicles when any modification is made that changes the standard vehicle dimensions in [TB 55-46-1/TB 55-46-2](#) or cargo height exceeds the highest point on the vehicle. These revised dimensions must be noted on the AUEL and DEL. For example, if machine gun mount rings are installed on trucks, the vehicle's height would change and require an adjustment on the AUEL.

SUPPORT REQUIREMENTS

3-35. Units notified for deployment may require assistance from nondeploying units in the form of maintenance, inspection, load teams, marshaling area, staging area, life support, and property transfer. The installation or area commander should use nondeploying units to provide this support. Units should be capable of deployment from the origin to the POE without external assistance.

LIFE SUPPORT

3-36. The supporting installation or area command should provide life support at staging and marshaling areas and at POEs.

MATERIALS-HANDLING EQUIPMENT

3-37. Units must identify requirements for MHE and CHE. These capabilities are not organic to most Army units. Requests must be specific and identify the exact weight, dimensions, and characteristics of what must be moved, lifted, or loaded.

PURGING OPERATIONS

3-38. When units are required to purge bulk fuel carriers, they will need access to an explosive meter or vapor tester to test for vapors. This type of equipment may be on

hand at the installation fire station or fuel support activity. Prior coordination must be made to obtain this support.

WASTE AND EXCESS FUEL

3-39. When units are required to drain fuel tanks or remove excess fuel, they must consider proper disposal or reclamation of the drained fuel. Planning and coordination is required to transport and discard waste fuel and acquire special equipment, such as hand pumps and containers for contaminated fuel. Unit commanders must ensure that all spills and contaminated fuel are disposed of in compliance with appropriate Federal, State, local, and HN environmental laws.

UNIT ALERT

3-40. Unit alert procedures may include the following:

ALERT ROSTERS

3-41. Units will maintain a roster of each member's name, telephone number, and address. The roster is organized so that the unit commander can contact one or more key members of the unit and can initiate a chain of notification. Using this roster, key members can tell who has been notified. Reporting procedures will be included in the unit SOP. A backup system must be established that includes strip maps and directions to the homes of key personnel. Alert rosters must be widely distributed to unit personnel. Units will verify alert rosters as prescribed by higher HQ.

BRIEFINGS

3-42. After the unit commander assesses METT-T, he will brief key personnel, soldiers, and family members. Briefings are given within security limitations and according to [AR 220-10](#). Briefings include, but are not limited to the following:

- Articles 85 through 87 of the UCMJ.
- The mission.
- Unit movement plans. The UMO will brief key personnel on deployment procedures, deployment duties of unit officers and NCOs, and variations from the SOP.
- Requirements for advance party, liaison personnel, movement teams, supercargoes, off-load preparation party, and escorts.
- Guidance to recall personnel attached/detached, on leave, on temporary duty, attending school, or nondeployable.
- Individual/unit equipment layout and related corrective action.
- Security guidance to include OPSEC and SAEDA.
- Equipment and vehicle requirements based on the AOs, such as recamouflaging. See [TB 43-0209](#) for camouflaging guidance.

- Requirements to retrieve equipment in maintenance prior to or after departure to HS.
- Requirements to retrieve loaned equipment.

SOLDIER READINESS PROCESSING

3-43. The commander must establish a soldier readiness review process. Certain readiness requirements must be met during this review. These requirements include personnel, medical, dental, legal, finance, and specific unit requirements in accordance with [AR 600-8-101](#). The unit must keep a personnel roster and screen personnel before deployment. The following paragraphs explain those duties for which the unit is responsible.

PERSONNEL ROSTER

3-44. The unit routinely monitors and maintains personnel status. The personnel roster shows shortages and nondeployable personnel. It is used for readiness reporting and manifesting for strategic deployment. Before embarkation, the unit commander will obtain a SIDPERS roster listing each element of the unit being moved. If the unit is to move directly from the HS to the POE, the roster is prepared and distributed according to instructions in the movement order.

SCREENING

3-45. Nondeployable personnel or those personnel not MOS qualified are identified and processed out of the deploying unit. Procedures for screening are performed according to applicable personnel regulations and command directives. [AR 614-30](#) and [AR 220-1](#) outline personnel availability criteria.

FINANCIAL READINESS

3-46. Soldiers should use direct deposit of their pay to a financial institution. Commanders with finance and accounting assistance must resolve problems concerning the pay of deploying service members as quickly as possible.

POSTAL INSTRUCTIONS

3-47. Deploying personnel will prepare a [DA Form 3955](#) for mail forwarding. The commander will ensure these forms are submitted to the appropriate postal facility before deployment.

SRP CHECKS

3-48. The supporting installation or area command must establish SRP checks for deploying personnel. Checks include personnel records, finance, legal, medical, dental, security, and the unit ministry team.

- The Military Personnel Division will ensure that each soldier has a current [SGLI Form 8286](#) and emergency data card ([DD Form 93](#)), correct ID tags and ID card, and other criteria in accordance with [AR 600-8-101](#).
- Finance and accounting handles those problems concerning surepay and pay problems, separation pay, direct deposit program, and pay records.
- Legal services ensure that the soldier has a properly documented last will and testament and has powers of attorney for required individuals.
- The medical activity ensures that the soldier's medical and immunization records are up-to-date according to current immunization requirements. It will also ensure DNA samples are taken as required. Personnel are given two pairs of eyeglasses and one pair of protective mask optical inserts.
- The dental activity ensures that the soldier's dental records show recent examinations and a panoramic X-ray. If, for any reason, a unit must deploy with its dental records, under no circumstances will soldiers and their dental records ride on the same conveyance.
- The Provost Marshal ensures that POVs are registered and prepared for storage or returned to family members.
- The UMT offers religious support to the deploying soldier. This may include religious items such as Bibles, crosses, and rosaries.

TRAINING REQUIREMENTS

3-49. The commander ensures that the soldier has completed required training before deployment. The deploying soldier must have completed the following:

- An APFT within the last 6 months. Even if a soldier has not successfully completed the APFT, he may still be deployable. These cases are subject to command review.
- Code of conduct training within the last 12 months.
- A SERE training peculiar to deployment destination.
- Weapon qualification within the last 12 months.
- SAEDA training within the past 12 months.
- Driver's training course for destination country.
- Mobilization briefing (RC).
- Legal briefing (RC).

RECORDS DISPOSITION

3-50. Records and information needed to operate effectively and efficiently at the new location will accompany the unit. Any remaining records will be transferred to the records holding area of the last permanent station.

PERSONAL RESPONSIBILITIES

3-51. The following are personal responsibilities that may affect the deployment process.

PERSONAL PROPERTY

3-52. Unit personnel are encouraged to use a power of attorney designating someone to ship and store their personal property. Unit personnel living in the barracks should properly pack, label, inventory, and turn in personal property not required or authorized in the overseas area. The unit's rear detachment is responsible for disposition of this property in coordination with the transportation activity.

PRIVATELY OWNED VEHICLES

3-53. Unit personnel may store POVs in a storage area designated by the installation or area commander or leave vehicles in the custody of a family member or other responsible individual. When time does not permit the procedures outlined above, the vehicle's keys and the power of attorney are left with the rear detachment commander or custodian or family member.

FAMILY MEMBERS

3-54. Unit commanders must arrange the unit personnel and family members' briefing. He must also ensure that unit personnel are given appointments with the family assistance officer. The family assistance officer is usually appointed from the staff of the command having control over the moving unit. The family assistance officer will perform the following:

- Advise family members of their entitlements for travel and shipment or storage of household goods.
- Advise family members of the need for their sponsors to leave a power of attorney or letter of authorization if family members are to make arrangements for shipment or storage of household goods and POVs.
- Advise family members of the services available through the Red Cross, Army Emergency Relief, and Army Community Services.
- Move family members if required.
- Clear quarters belonging to family members.
- Emphasize the need for a will.
- Establish a chain of concern for family support group members to obtain support and information.

INDIVIDUAL CLOTHING AND EQUIPMENT INSPECTION

3-55. This inspection is coordinated with the issuance of any equipment peculiar to the deployment. All individual equipment, clothing, and unit equipment is accounted for according to the unit supply update, including [DA Form 3645/DA Form 4886](#).

3-56. Unit movement plans will include arrangements for transporting troops to an issue facility to fill shortfalls. The soldier's rucksack contains clothing items that are required while en route and upon arrival at the unit's destination.

SECURITY

3-57. Equipment should be guarded while it is being staged at the installation, at railheads, or en route to POEs. The degree of security required will determine if outside support is needed. At a minimum, equipment should be protected against theft and pilferage.

KEY CONTROL

3-58. Units will wire ignition keys of deploying vehicles to the steering column. When containers are padlocked, two sets of keys will be available for each locked item (one set for the supercargoes or escorts and one set for the custodian). Deploying unit liaisons must ensure that drivers, supercargoes, guards, and escorts turn in any government keys. A key custodian is appointed during the period to help with specialized cargo that may require keys.

IDENTIFICATION MARKINGS

3-59. Unless directed, units will not cover or obliterate equipment markings.

CLASSIFIED MATERIAL

3-60. When handling classified material, the deploying unit must perform the following steps before deployment:

- Dispose of nonessential files according to [AR 380-5](#) and local SOP.
- Consult security or information management directorate for disposition of classified or cryptographic material.
- Prepare classified cargo (see [Appendix F](#)).
- Assign escorts or supercargoes (see [Appendix G](#)) for classified cargo (see [Appendix F](#)).

OVERSEAS ORIENTATION

3-61. Before moving, the commander will brief the unit on the projected AOs. The installation or area commander will provide assistance in assembling information for unit commanders. The briefing will cover the following:

- Mission and threat.
- Geography (location, topography, and climate).
- People (population, race, religion, customs, values, and language).
- Economy.
- Infrastructure.
- Natural resources and special environmental considerations.
- History.
- Defense forces.
- Political systems.
- Local laws including applicable environmental regulations and laws.
- SOFA.
- Force protection and hazards of the area.

CLEARANCE FROM THE INSTALLATION

3-62. The unit commander must clear from the installation/HS before deployment. During rapid deployment, the commander may appoint the rear detachment commander to perform administrative and supply functions, such as accounting for material not accompanying the unit. During clearance, the commander may consider the following:

- **TOE equipment.** Not all of a unit's TOE equipment may accompany the unit. For example, if the unit will be drawing PWRS or if a portion of the TOE equipment is deemed nonmission essential, then all of the TOE equipment may not accompany the unit. This equipment may be turned over to the rear detachment commander or to the installation.
- **Nonmission essential equipment and installation property authorized by TDAs or CTAs.** A hand receipt or annex should be prepared for station property.
- **Excess POL and PLL.** Turn in excess POL and PLL.
- **Fixed facilities.** A listing of motor pools, troop billets, and administration buildings, as well as accompanying material must be turned in to the installation or transferred to a nondeployed unit.
- **Outstanding requisitions.** Ten days before departure, outstanding requisitions should be cancelled or a ship to address given to the servicing SSA according to [AR 710-2](#).

MAINTENANCE

3-63. Maintenance is a key facet of vehicle preparation. Special requirements are needed in hot and cold weather environments.

HOT WEATHER ENVIRONMENTS

3-64. Personnel must devote extra attention to vehicle preventive maintenance schedules. The unit must have special parts, oils, and lubricants to operate in deserts or hot climates. Before deploying to areas having these type climates, personnel must do the following:

- Add corrosion inhibitor compound to the cooling systems. Scale and rust form faster in high temperature environments. Test radiator caps, which are a common cause of overheating (refer to [TM 750-254](#)). Check for correct levels of water, coolant, and oil, which expand with heat and overflow. Clean and service all air cleaners and hoses. Dust entering through holes will destroy an engine.
- Carry greater quantities of lower maintenance category repair parts and lubricants. Tire life is shortened. Oil is used up more quickly in diesel powered engines. Extra coolant, hoses, clamps, and filters are needed because they must be replaced more often. Make sure to stock other supplies that will be needed in an arid environment, such as water cans and dust brushes.
- Use solar heat reflecting paint for radios (refer to [TB 43-0118](#)).

Consult [TB 43-0239](#) and [FM 90-3](#) for more information on maintaining equipment in arid environments.

COLD WEATHER ENVIRONMENTS

3-65. When deploying to a cold weather climate, personnel will perform the following:

- Check the vehicle's TM for the proper winterization kit. Add antifreeze according to [TB 750-651](#). Stock the correct seasonal oil (check the lube order) and fuel. Stock fuel system icing inhibitor and methyl alcohol (methanol) for alcohol evaporators.
- Check battery electrolyte levels and fully charge all batteries according to [TM 9-6140-200-14](#).
- Inspect for serviceable slave cable receptacles.

Consult [FM 9-207](#) for more information on maintaining equipment in cold weather.

[RDL](#)[Table of](#)[Document](#)[Download](#)[Homepage](#) [Contents](#) [Information](#) [Instructions](#)

Chapter 4

Air Movement Operations

Air travel is the only transportation method that meets world situations requiring immediate response. Air movement of units requires planning at all command levels. Units must be trained to skillfully execute an air deployment. This chapter provides a brief overview of missions, responsibilities, and general instructions for conducting strategic air movement. [FM 55-9](#) and [FM 55-12](#) provide detailed guidance for air movement planning and loading procedures.

TYPES OF AIR MOVEMENTS

4-1. There are two types of air movement (nontactical [administrative] and tactical [combat]). Army units plan for nontactical movements unless they are conducting forced entry operations.

NONTACTICAL MOVEMENT

4-2. A nontactical movement is a movement of troops and equipment that is organized, loaded, and transported to expedite movement and conserve time and energy when no enemy interference is anticipated. It emphasizes economical use of the aircraft cabin space and maximum use of the ACL. The ACL is the amount of cargo and passengers (as determined by weight, cubic displacement, and distance to be flown) that may be transported by a specific type of aircraft. Unit integrity or off-loading sequence is second in priority to load efficiency when planning a nontactical movement.

TACTICAL MOVEMENT

4-3. A tactical movement is a movement of troops and equipment that is organized, loaded, and transported to facilitate accomplishment of a tactical mission. The arrangement of personnel, equipment, and supplies is designed to conform to the anticipated tactical operation of the unit. Proper use of the aircraft ACL is still an important factor, but the commander's sequence of employment has priority.

AIR FORCE AIRLIFT AIRCRAFT

4-4. Deployment planners must be familiar with the types of available aircraft and their characteristics. The aircraft of primary concern are the C-141, C-5, C-17, and KC-10. The C-130 may be used for strategic movement, but it is normally used in a theater role. The cargo compartments may be configured to accommodate unit vehicles, palletized cargo, and troops. The wide range of cargo carried by these aircraft, along with the many combinations of loads, provides great flexibility in moving troops and equipment.

AIRCRAFT CHARACTERISTICS

4-5. If a complete file of Air Force publications is not available, the unit's affiliated AMC AMCS will assist the unit load planners. The AMCS is an extension of the unit's staff for all airlift planning. Important aircraft characteristics include the following:

- The size of the cargo door and its location and height above the ground.
- The size and shape of the cargo compartment.
- The strength of the aircraft floor.
- The seating configuration available for airlifting troops.

C-130

4-6. The C-130 Hercules is a four-engine, turbo-prop, medium-range assault transport airplane. Its short field capability makes it suitable for tactical and theater air transport. [Figure 4-1](#), shows the aircraft's characteristics.

C-130 Hercules

Speed: 290 knots/365 mph
Max Payload: 0,174 lb
Cargo: 6 pallets or 90 passengers
Cargo Compartment Dimensions:
Length: 624 inches
Width: 123 inches/106 usable
Height: 108 inches

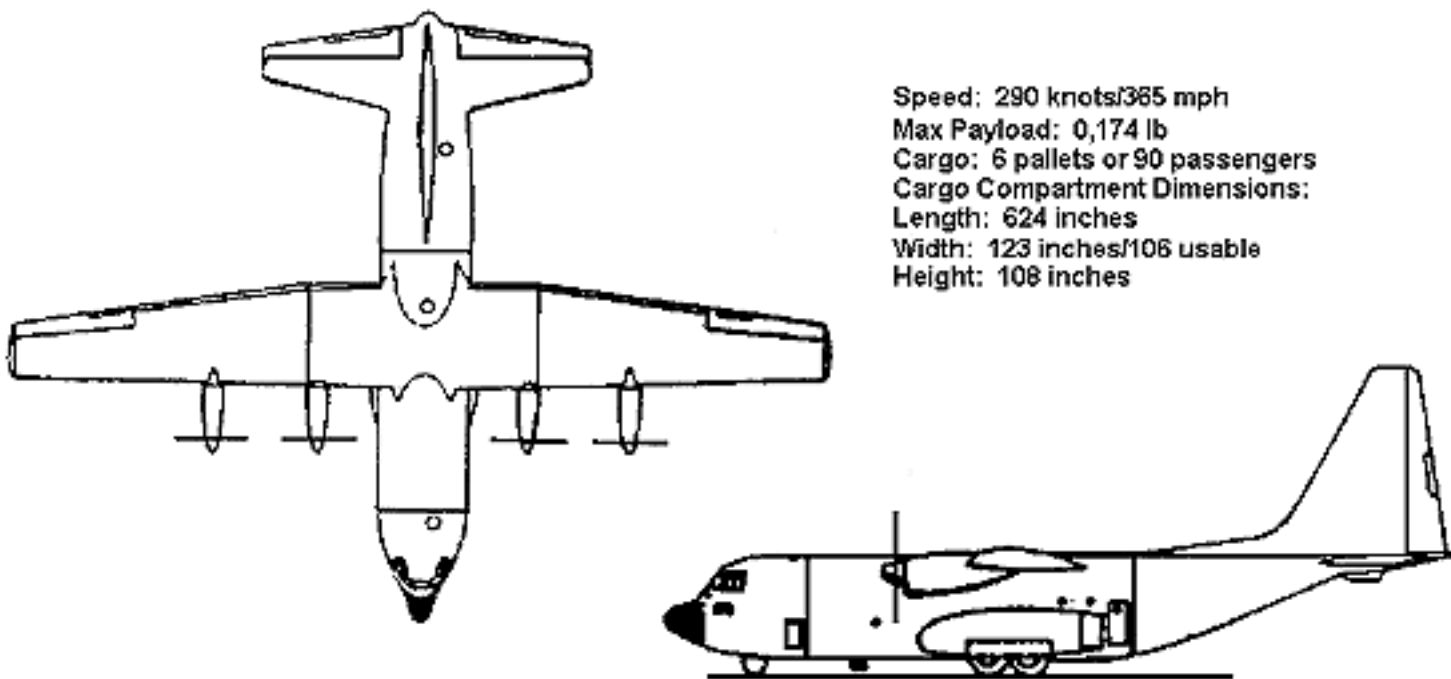

Figure 4-1. C-130 Aircraft Characteristics

C-141

4-7. The C-141 Starlifter is a high-wing, four-engine, turbofan, heavy-transport airplane. Used mainly in a strategic role, it is the core aircraft used for basic air movement planning. Cargo area dimensions are for general planning purposes only. [Figure 4-2](#), shows the aircraft's characteristics.

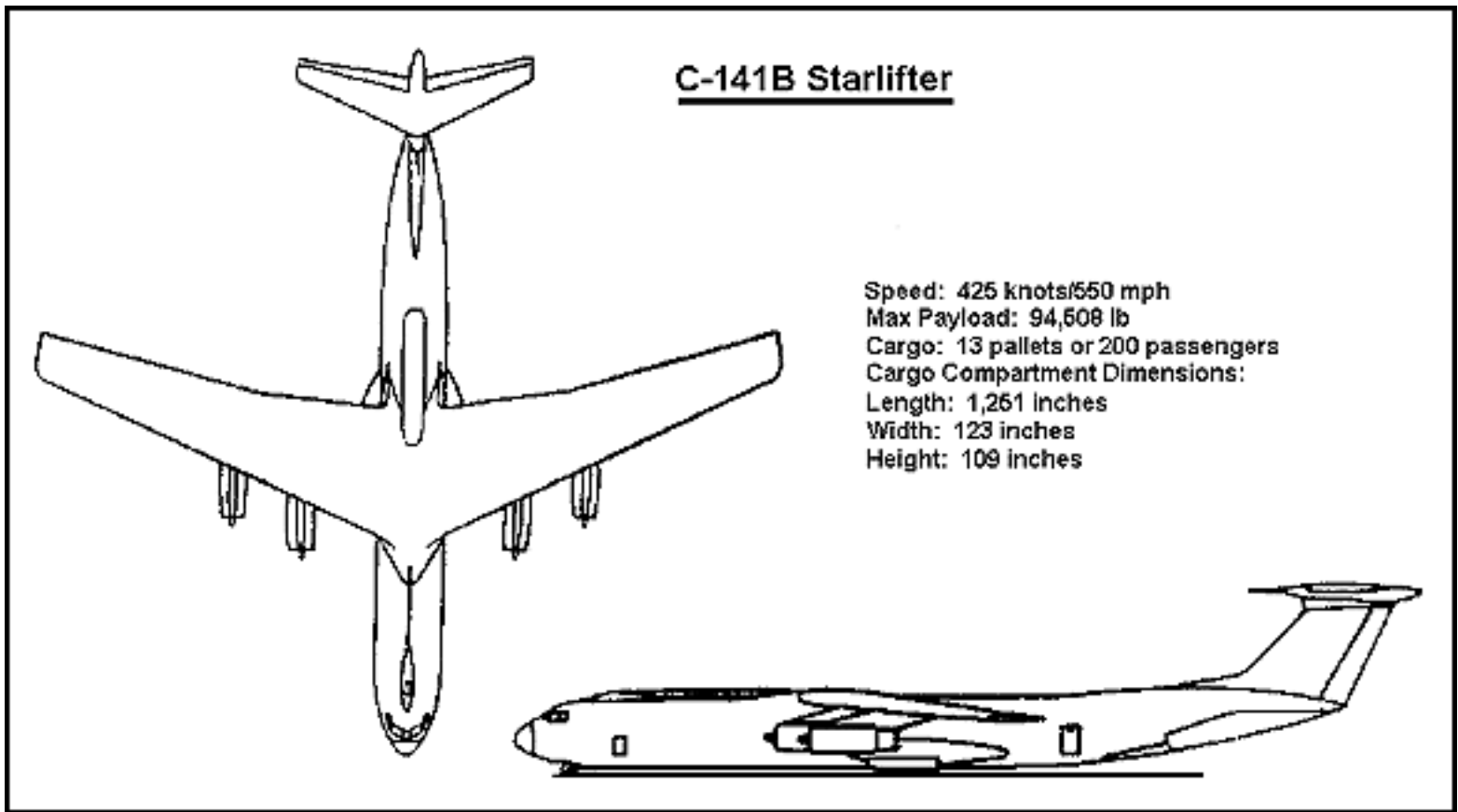

Figure 4-2. C-141 Aircraft Characteristics

C-5

4-8. The C-5 Galaxy is a high-wing, four-engine, turbofan, heavy-transport airplane. It is used mainly in a strategic role to airlift cargo considered oversized to the C-141. Unique features of this aircraft are the forward cargo door (visor) and ramp, the aft cargo door system and ramp, and a separate passenger compartment. These features allow drive-on/drive-off loading and unloading. [Figure 4-3](#), shows the aircraft's characteristics.

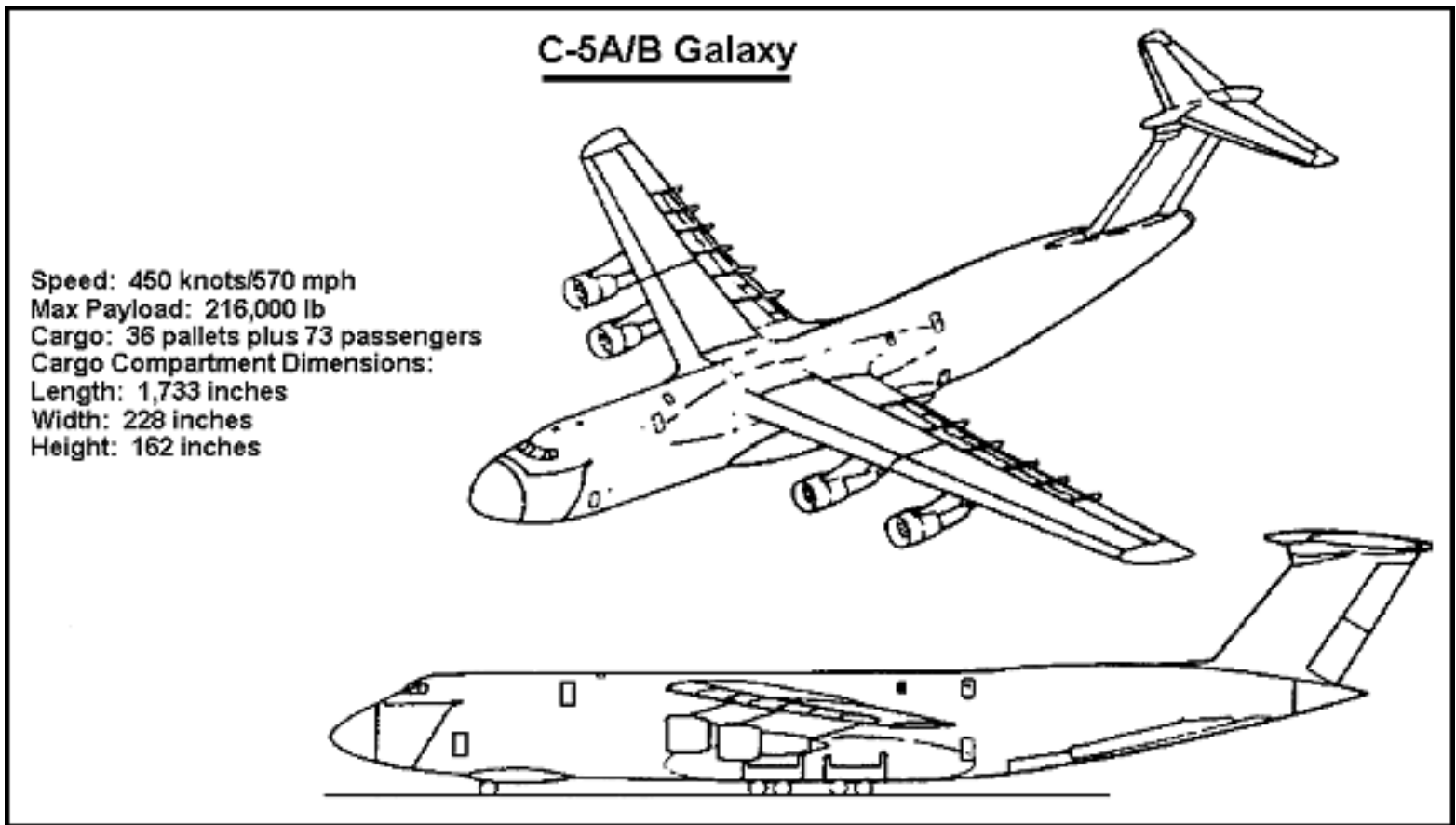

Figure 4-3. C-5 Aircraft Characteristics

C-17

4-9. The C-17 Globemaster III is a high-wing, four-engine, turbofan, heavy transport airplane scheduled to replace the C-141 in its role as the core strategic airlift asset. The C-17 has approximately the same wingspan as the C-141 but can carry twice the payload. It can deliver the same outsize equipment as the C-5 into small airfields previously restricted to the C-130. This ability to land on short runways with anticipated payloads up to 169,000 pounds enables delivery of equipment directly to short airfields without intermediate transshipment. [Figure 4-4](#) shows the aircraft's characteristics.

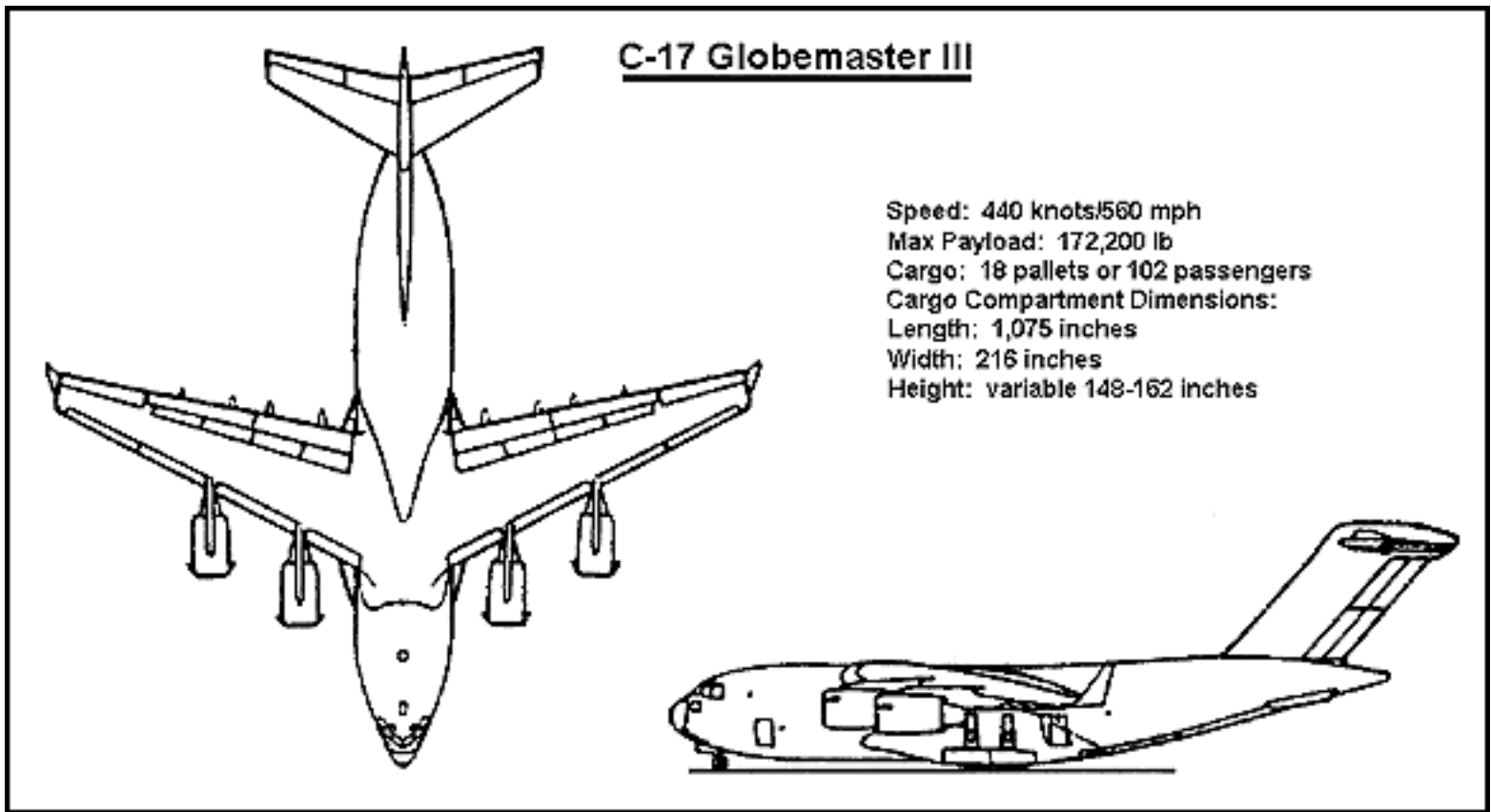

Figure 4-4. C-17 Aircraft Characteristics

KC-10

4-10. The KC-10 Extender is a swept-wing, wide-body, tri-jet with a dual purpose mission as an aerial refueler and cargo/passenger aircraft. Unit personnel, equipment, and materiel are carried on the upper deck, and fuel tanks are contained in the lower compartments of the fuselage. The unique loading requirements and limitations for the KC-10 require special equipment and attention. This aircraft does not have a ramp at ground level and requires the use of a wide-body elevating loader. [Figure 4-5](#) shows the aircraft's characteristics.

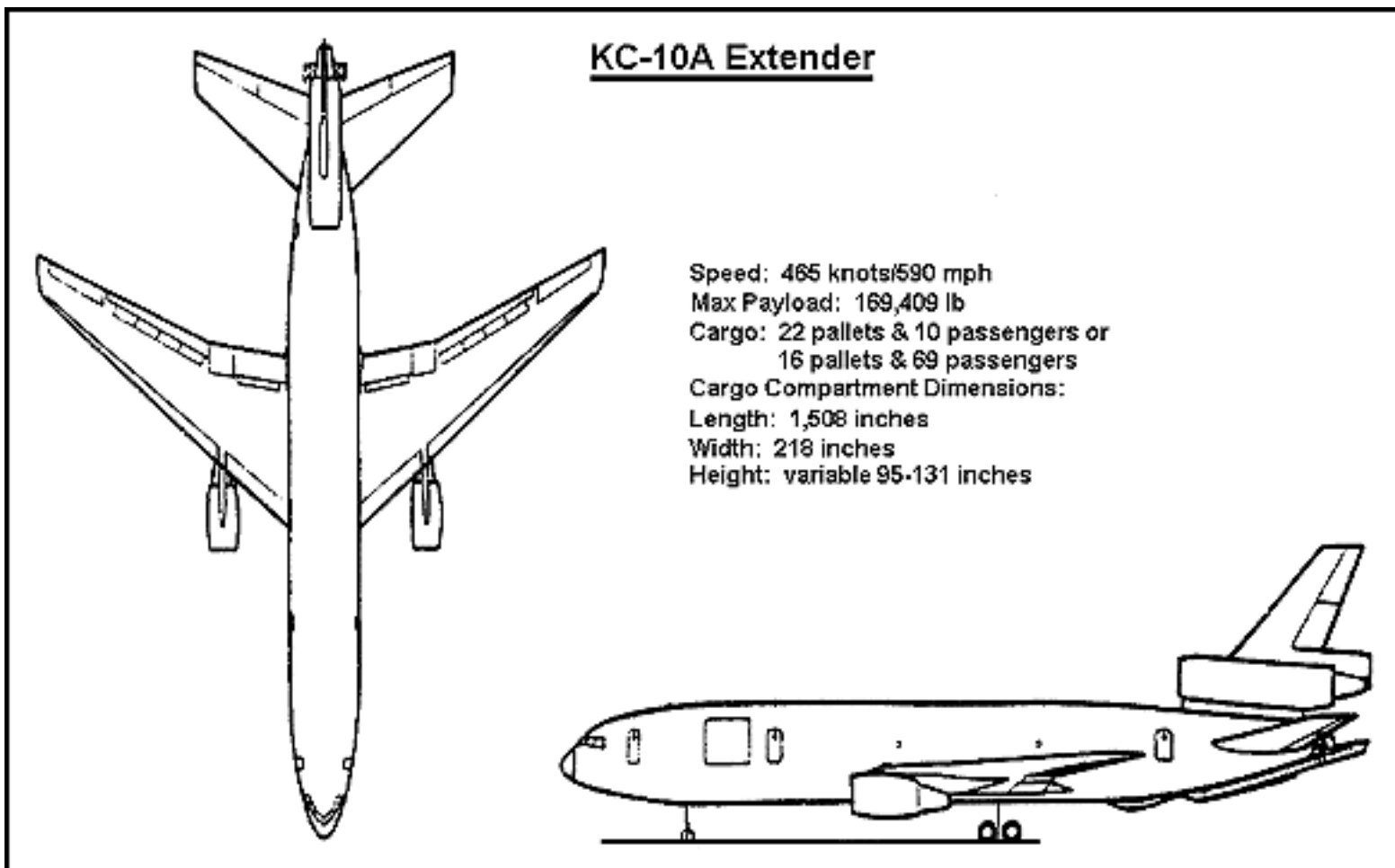

Figure 4-5. KC-10 Aircraft Characteristics

CIVIL RESERVE AIR FLEET AIRCRAFT

4-11. In a national emergency, military airlift may be in short supply. CRAF is a program that employs the aircraft and support capability of US civil air carriers to rapidly augment organic military airlift forces during periods of increased airlift activity. During deployment, many units will use civilian aircraft to deploy most of the personnel and some unit equipment. Air Force aircraft will be used to carry large vehicles and equipment. CRAF is activated in three stages to provide AMC with the flexibility to tailor the airlift force to meet the needs of various degrees of airlift shortfall. The three stages are as follows:

- Stage I is activated by the CINC USTRANSCOM to provide responsive support during a committed expansion of airlift capability. Peacetime procedures remain in effect. This stage is only an expansion of airlift capability contractually committed to call-up. Carriers have 24 hours to make aircraft available for missions.
- Stage II is activated by CINC USTRANSCOM upon approval of the SECDEF. It provides additional airlift to support an airlift emergency. This stage increases the capability more than Stage I without resorting to full mobilization. Carriers have 24 hours to make aircraft available.

- Stage III provides the total CRAF capability for major military emergencies warranting a full mobilization of US forces. The CINC USTRANSCOM issues the order to activate CRAF Stage III only after the President or Congress declares a national emergency. Carriers have 48 hours to make aircraft available.

4-12. Deployments with CRAF aircraft require considerations not usually encountered in loading military aircraft. The cargo compartment of a B-747, for example, is 16 feet AGL. Standard military MHE cannot load the aircraft.

4-13. Unlike standardized military cargo aircraft, civilian airframes vary widely. It is not uncommon for the same type, model, and series of civil aircraft to vary greatly depending on the carrier's needs. All CRAF aircraft will need some modification before military vehicles and equipment can be loaded and transported on them. The deploying force may have to install a 463L pallet subfloor before loading vehicles. Even then, any vehicle heavier than a 2 1/2-ton truck cannot be loaded onto most civilian aircraft.

4-14. The roller/restraint systems in most civilian aircraft will accept a military 463L pallet with some modification. Weight and height restrictions are also critical. Differences in fuselage configurations will cause pallet load heights to vary, especially in the lower lobes of wide body aircraft. More in-depth guidance on type, model, and series capabilities is contained in [AMCP 55-41](#) and [FM 55-9](#). The servicing AMCS can provide assistance.

THE 463L CARGO SYSTEM

4-15. The 463L cargo system includes the pallets, nets, MHE, and aircraft rails and roller system. The overall dimensions of the 463L pallet is 88 X 108 inches. The usable dimensions are 84 X 104 inches. This allows two inches around the load to attach straps, nets, or other restraint devices. An empty 463L pallet weighs 290 pounds and 355 pounds with nets.

4-16. The rails and roller system consists of rows of rollers and rails that allow the palletized cargo to easily move into the aircraft. Supplies and equipment are placed on 463L cargo pallets and secured with cargo restraining nets. The three standard nets of the 463L pallet system will restrain up to 10,000 pounds of general cargo, 96 inches high.

4-17. The 463L pallet may be used as a mobility platform for other than general cargo weighing more than 10,000 pounds. Palletized loads over 10,000 pounds must be restrained with chains and devices to the aircraft floor, the pallet rings, or restraint rail tie-down rings. Palletized loads exceeding 10,000 pounds requires coordination with AMC.

4-18. Pallets are available to units planning or executing an air movement through their ITO/ICUMO from AMC. The user is responsible for building 463L pallets and may be responsible for loading them onto aircraft. [FM 55-9](#) provides detailed

guidance on pallet building and documentation.

UNIT AIR MOVEMENT PLANNING

4-19. Air movement planning is a critical skill that requires training and experience. The challenge is to determine the number and types of aircraft required to support the movement mission.

4-20. The first step in air movement planning is to determine whether the movement is tactical or nontactical. This depends on the unit's mission upon arrival in the theater. The mission may drive the type of aircraft allocated for the movement. The next step is to determine what will move by air, the type of aircraft anticipated, commander's guidance, the unit's movement priority, and the priority of movement for personnel and equipment within the unit. Based on this information, the planner can determine and request the number of sorties by type of aircraft required to complete the mission. For nontactical movements, aircraft must be used to their maximum capability based upon applicable ACL and available passenger seats.

4-21. Plan vehicle loads with as much unit equipment as possible up to the load capacity of the vehicle. To ensure accurate movement planning figures, measure and weigh the vehicles planned for each load. [FM 55-12](#) provides guidance for weighing and marking the vehicles.

4-22. Aircraft are requested based on [DD Form 2327](#). This form requires weight and dimension data, to include the cargo weight of the vehicles carrying cargo. Each aircraft load requires a cargo manifest. Use DD Forms 2130-series (depending on the type of aircraft being used) or automated planning systems (CALM/ALM) to plan the placement of each vehicle and item of equipment. Refer to [FM 55-12](#) for guidance on completing the manual forms. See AFM 28-346 for more information on CALM.

4-23. Two methods of determining aircraft (sortie) requirements are the weight and type load methods. These methods are described as follows:

- Use the weight method to calculate sortie requirements to transport large amounts of vehicles, general cargo, and personnel. This method is based on the assumption that total weight, not volume, is the determining factor. MACOM level planners normally use this method to quickly approximate airlift requirements.
- Use the type load method to calculate individual sortie requirements for like loads. In most unit air movements, a number of the aircraft loads can contain the same items of equipment and number of personnel. Preparing identical type loads greatly simplifies planning and makes manifesting easier. This method is normally used by unit level planners.

AIRCRAFT LOAD PLANNING

4-24. Air load planning is a critical skill that requires training and certification. Units that plan to deploy by air must have certified air load planners to develop viable air load plans. The load planner must perform the following:

- Ensure the safe and efficient use of the aircraft.
- Comply with aircraft safety, weight and balance, and floor load restrictions.
- Ensure that the load is within an acceptable CB condition for takeoff, flight, and landing.
- Coordinate loading with the aircraft loadmaster.

The load planner must also keep other factors in mind such as ease of on load and off load. Improper planning can result in excessive loading or off loading time or structural failure in flight or on landing. A load properly planned and coordinated will go on the aircraft quickly, safely, and with minimum difficulty.

MANIFESTING

4-25. During manifesting, load planners complete the final load plan and cargo manifests. The final load plans may differ from the preplanned ones due to changes in unit movement priorities, aircraft scheduling, or equipment due to breakage in the marshaling yard. The planner identifies the unit equipment and passengers for each aircraft. Final manifesting with actual weights at the airfield is normally completed with automated systems. However, planners must be prepared to use manual systems (templates on DD Form 2130-series) when automation is not available. See [FM 55-12](#) for further guidance.

TYPES OF LOADS

4-26. The two basic types of loads are concentrated loads and palletized loads. These loads are described as follows:

- A concentrated load is a very large or heavy item, such as vehicles, tanks, or construction equipment. Planners must compute the precise station location on which the item is to be placed inside the aircraft and determine and mark the CB. Since station computations enter into this method of loading, it is also called station loading.
- A palletized load consists of 463L pallets. The center of each pallet is its CB unless otherwise marked. The 463L restraint rail system positions and secures the pallets in the aircraft. Army units build their own 463L pallet loads. They must identify 463L pallet requirements so the Air Force can properly prepare the aircraft.

GENERAL RULES

4-27. General rules of loading apply to all aircraft. These rules are as follows:

- Plan to move general bulk cargo, such as boxes or crates, on the back of cargo carrying trucks or trailers.
- When loading cargo in the beds of trucks or in trailers, do not exceed the rated capacity of the vehicle.
- When loading 463L pallets, use forklifts rated at a lifting capacity equal to or greater than the pallet weight. Normally, 10K AT and/or RT forklifts are used.
- Identify in advance any additional required loading aids to ensure availability at the equipment load time. Examples are shoring, aircraft winch, and MHE. (Aircraft ground time is minimized when the unit is prepared to load.)
- Use shoring to prevent damage to the aircraft floor or airfield pavement.
- Do not deflate vehicle tires to achieve vehicle height clearance to fit within the aircraft loading envelope.
- Do not use the book weight of items for weight and balance purposes when the actual airlift occurs. Use the actual scale weight.
- Do not exceed the aircraft limitations specified in [FM 55-9](#).
- Plan on a driver and assistant driver to accompany each vehicle.
- Keep the associated trailer connected to its prime mover for ease of off-load.

Although the load planner knows the general rules for planning aircraft loading, there are other considerations when loading the C-130, C-141, and C-17. None of these aircraft has a separate troop compartment; therefore, when planning troop movements, cargo carrying capacity is sacrificed. Cargo loads restrict the number of troops that can be carried.

LOAD PLANNING FACTORS

4-28. Many factors must be considered in the load planning process. Among these are the allowable cabin load, cargo weight and CB, and aircraft cargo load CB.

ALLOWABLE CABIN LOAD

4-29. The load planner must know the ACL for a particular aircraft. ACL is the weight of cargo and personnel that an aircraft can carry. Air Force personnel provide the ACL for each operation. Several varying factors determine the ACL such as, the critical leg of the route and departure and arrival airfield characteristics. The ACLs shown in [Table 4-1](#) are based on a 3,200 NM range and are for general planning purposes only.

Table 4-1. Allowable Cabin Loads

C-130E/H	25,000 pounds*
C-141B	46,000 pounds

KC-10	80,000 pounds
C-5	130,000 pounds
C-17	90,000 pounds
*The C-130 ACL is not based on 3,200 NM range.	
NOTE: Actual planning ACLs for each aircraft may be obtained from the unit's affiliated AMC airlift control squadron. Based on the mission, accurate ACL information can only be obtained from known operating conditions.	

CARGO WEIGHT AND CB

4-30. The transported unit is responsible for weighing and marking the cargo CB for air movement. The cargo weight and CB must be determined to accurately compute the weight and balance condition of a loaded aircraft. Every piece of cargo must be weighed. Every item measuring 10 feet or longer or having a balance point other than the center must be marked with its CB.

4-31. Weigh and mark all vehicles (without driver) after secondary cargo has been loaded and secured. Weigh and mark prime movers and trailers as they will be loaded on the aircraft (connected or disconnected). The CB is not normally marked on pallets. Once the weight and CB are determined, nothing can be added or moved without reweighing and remarking the cargo. See [FM 55-12](#) for detailed procedures on weighing and marking cargo.

AIRCRAFT CARGO LOAD CB

4-32. Since balance of the aircraft is mainly affected by weight variations along the longitudinal axis of the cargo inside the aircraft, the term CB refers to the balance point of items of cargo or equipment that go into the aircraft. Each aircraft has a CB range. All aircraft loads must have a CB within the range of the specific aircraft. Compute the total load weight and CB to ensure that the limits of the aircraft are not exceeded. To do this, you need to know the following:

- Weight of each vehicle or piece of cargo.
- Fuselage station CB of each vehicle or piece of cargo as it is located within an aircraft.
- Total cargo CB limitations range of the aircraft.

Refer to [FM 55-9](#) and [FM 55-12](#) for aircraft cargo load CB computations.

AIR TERMINALS

4-33. Air terminal operations occur at military and civilian air fields. The air terminal commander or civilian operator is responsible for air terminal operations. The Army or other service component commander will provide an A/DACG to control Army activities at the terminal. The A/DACG may also be responsible for loading and unloading aircraft and cargo at these facilities. Deploying units coordinate with the A/DACG for their responsibilities in processing through the terminal. The Air Force TALCE supervises Air Force operations at the air terminal. The A/DACG and the TALCE must coordinate support responsibilities prior to the start of operations. See [Chapter 7](#) for departure air terminal operations and [Chapter 8](#) for arrival air terminal operations.

AIRCRAFT LOADING GUIDANCE

4-34. A variety of techniques can be used to load aircraft. Aircraft are usually loaded according to the unit's load plans. However, the aircraft loadmaster is the final authority on how cargo is to be loaded and positioned aboard an aircraft. The DACG normally does the loading under the supervision of the loadmaster.

LOADING TECHNIQUES

4-35. The basic techniques for loading are described below.

Drive-on/Drive-off. The vehicle or prime mover is driven or backed under its own power into the aircraft cargo compartment. This method is generally the easiest for loading vehicles and is also used for vehicles with towed loads and for tractor-trailer units.

Towed or Pushed Loads. Certain loads, such as trailers, must be towed or backed aboard the aircraft either by a prime mover or pusher vehicle. A pusher vehicle equipped with a front-mounted pintle hook is particularly helpful in pushing large trailers aboard the aircraft because the driver can more easily control the operation. If the towed load remains with the prime mover aboard the aircraft, the trailer may or may not remain hitched to the prime mover inside the aircraft. The loadmaster may direct that the trailer be uncoupled. In that case, the tongue is normally lowered on the aircraft floor under the prime mover. Semitrailers may not be disconnected. Ensure that proper shoring is placed under the tongue to prevent metal-to-metal damage to the aircraft floor.

Winched Loads. It may be necessary to winch wheeled or tracked vehicles, helicopters, and palletized cargo into the aircraft. This method is very useful where cargo compartment clearances and ramp inclines are difficult to negotiate. The winch may also be used to unload cargo or vehicles to control movement down the ramp.

Direct Loading From Vehicles. In this method, a vehicle delivers cargo directly to the aircraft. The vehicle is positioned close to the aircraft ramp or door, permitting direct transfer of the cargo from the vehicle to the aircraft cargo compartment.

SHORING

4-36. Some items loaded on aircraft require shoring. The moving unit provides this shoring when required. Shoring is made of lumber, planking, or similar material. Shoring does the following:

- Protects the aircraft cargo floor or 463L pallet surfaces.
- Decreases the approach angle of aircraft ramps.
- Protects airport parking ramps.
- Spreads weight over a larger area.

The requirement for shoring is based on the type of aircraft. Units obtain shoring through their DPW or area command. Units should save shoring for redeployment. The affiliated AMCS can provide technical guidance on shoring requirements and dimensions. [FM 55-9](#) provides additional information on the types of shoring and their uses.

4-37. When shoring is required to load cargo, it will also be needed to unload. If shoring is not available at the destination, then the shoring must be transported with the load. Include the weight of the shoring with the weight of the cargo. For tracked vehicles, simply load the lumber on top of the vehicle while it is being weighed. For rough terrain forklifts or other pieces of equipment that require sleeper shoring, weigh the shoring separately and add the weight to the vehicle weight.

CARGO RESTRAINTS

4-38. Cargo must be restrained (tied down) in an aircraft so that it remains stationary in the cargo compartment when the aircraft is subjected to turbulence, vibration, acceleration, deceleration, and landings. Restrain cargo with tie-down devices provided aboard the aircraft. [FM 55-9](#) gives detailed instructions on how to restrain cargo.

SAFETY

4-39. Safety is a very important consideration in any airlift movement to prevent injury to personnel and damage to equipment. Safety is the result of effective training, common sense, and alertness. Leaders at all levels are responsible for evaluating the risk of each phase of every air movement operation. Hearing protection will be used as needed during all air movement operations. [FM 55-9](#) covers specific safety measures for vehicle operations during aircraft loading.

FLIGHT LINE SAFETY

4-40. Personnel on the flight line will observe the following:

- Will not smoke on the aircraft parking ramp area or flight line.
- Will not walk in front of any aircraft when the engines are running. Personnel must never walk within the propeller arc.
- Will observe a 15 mph speed limit for all vehicles on the flight line, a 5 mph speed limit for all vehicles within 25 feet of an aircraft, and a 3 mph (walking speed) when within 10 feet of the aircraft.
- Will not approach within 50 feet of an engine intake or within 200 feet of the blast area to the rear when jet engines are running. On propeller-driven aircraft, the danger area is 10 feet in front of the propeller and 200 feet to the rear.
- Will not drive vehicles under any part of the aircraft.
- Will not drive or park vehicles, except those being loaded or off-loaded, within 10 feet of an aircraft without a walking guide to observe clearance between vehicle and aircraft.
- Will approach an aircraft in a vehicle with the driver's side nearest the aircraft. Personnel will park the vehicle parallel to the aircraft wings.
- Will not allow trash or debris to be thrown on the flight line. Personnel will also ensure that canvas or small pieces of equipment are secure to prevent the jet exhaust from blowing them around.
- Will not back vehicles toward or into an aircraft without spotters placed at the front and rear corners of the vehicle. Spotters should not be directly in front of or behind any moving vehicle. The aircraft loadmaster directs all backing. Vehicles backing toward aircraft cargo doors, other than the vehicle loading ramp, should have a chalk block placed between the vehicle and the aircraft at a position to stop the vehicle before it could strike the aircraft.
- Will not allow troop formations on the flight line without Air Force or D/AACG escort. Troops move on the airfield in controlled formation only; halt at least 100 feet from the edge of runways, taxi strips, and ramps; and get clearance before crossing. Units will not hold standing formations on the flight line.

IN-FLIGHT SAFETY

4-41. While in flight, personnel will follow instructions of the aircraft commander and observe the following:

- Will keep seat belts fastened when taking off or landing and when ordered by the aircraft commander.
- Will not smoke.
- Will not operate electronic devices.
- Will follow the instructions of the aircraft commander or designated representative in the event of an emergency.

OFF LOAD SAFETY

4-42. When deplaning or off loading, personnel will observe the following:

- Will not remove any restraint devices or start vehicles until instructed by the aircraft loadmaster.
- Will exit the aircraft on direction of the aircraft loadmaster and ground guides.
- Will have vehicles proceed directly aft of the aircraft at least 25 feet before making any turns.

[RDL](#)[Table of](#)[Document](#)[Download](#)[Homepage](#) [Contents](#) [Information](#) [Instructions](#)

Chapter 5

Convoy Operations

Convoy operations are planned according to [FM 55-30](#) and [FM 55-312](#). Joint Service regulations [AR 55-29](#), [AR 55-162](#), and [AR 55-80](#) provide guidance on oversize/overweight vehicles and convoy moves. Civil highway authorities set limits on vehicle weight, length, width, and height to ensure the safety of the highway user and to preclude damage to the infrastructure. DOD policy states that no vehicle movement that exceeds legal limitations or regulations, or that subjects highway users to unusual hazards, will be made without permission from state, local, and/or toll authorities. Loads that exceed maximum allowable weight or dimensions will be transported by other modes or commercial transporters that conform with the limits of each state.

Special provisions apply during a national defense emergency and for certain other critical defense moves. During emergencies, permit requests may be made by the most expeditious means of communication available. Convoys and oversize/overweight moves must be coordinated with civil authorities to ensure that the selected routes are passable. These moves may be made without prior written permits from civil authorities. However, all requests should later be confirmed in writing. The POCs for coordinating movement are given in the MTMCTEA's Directory of Highway Permit Officials and MOBCON Coordinators.

CONVOY ORGANIZATION

5-1. The organization of a convoy consists of the following:

ORGANIZATIONAL ELEMENTS

5-2. A convoy commander can better control a convoy if it is broken into smaller, more manageable groups. Whenever possible, convoys are organized along organizational lines, such as platoon, company, and battalion. The three organizational elements of a convoy are a march column, a serial, and a march unit (see [Figure 5-1](#)). They are described as follows:

- A march column is a group of two to five serials. It represents approximately a battalion-to-brigade size element. Each column has a column commander.
- A serial is a subdivision of the march column. It consists of elements of a march column (convoy) moving from one area over the same route at the same time. All the elements move to the same area and are grouped under a serial commander. The serial commander is directly responsible to the convoy

commander. A serial may be divided into two or more march units.

- A march unit is a subdivision of the serial. It comes under the direct control of the march unit commander. It is the smallest organized subgroup of the convoy and usually will not exceed 20 vehicles.

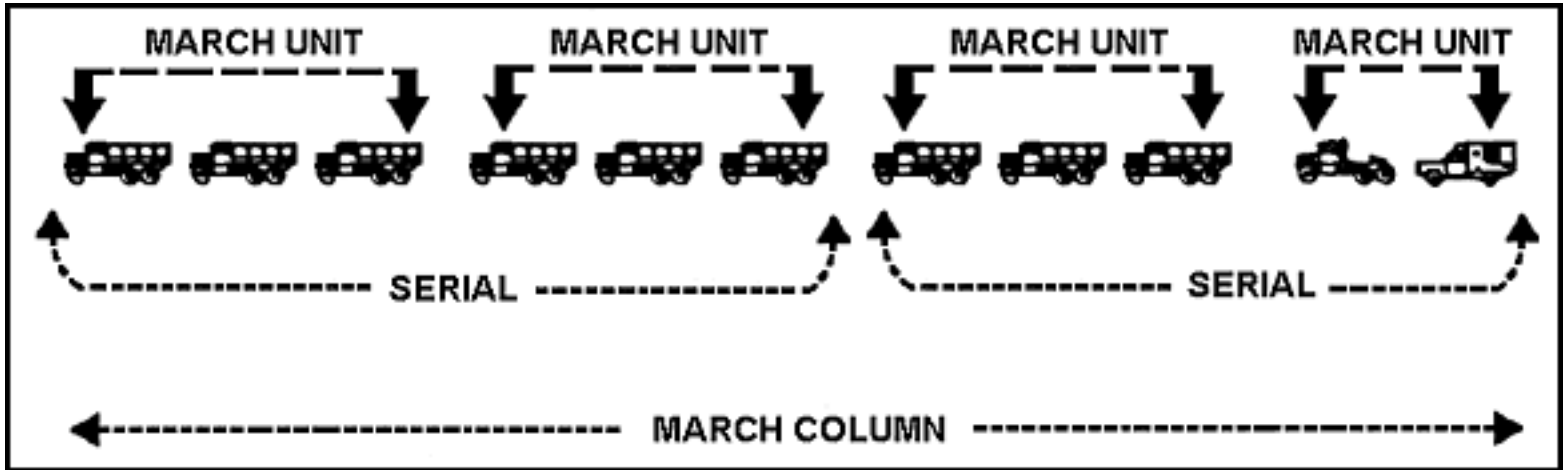

Figure 5-1. Convoy Organizational Elements

FUNCTIONAL ELEMENTS

5-3. All convoys, regardless of size, are made up of three functional elements. These elements consist of a head, a main body, and a trail (see [Figure 5-2](#)). These elements are explained as follows:

- The head is the first vehicle of each column, serial, or march unit. It carries the pacesetter, who sets the pace to maintain the prescribed schedules and rates of march. The pacesetter leads the convoy on the proper route. With the head performing these duties, the convoy commander is free to move up and down the convoy to enforce march discipline.
- The main body follows right behind the head (pacesetter) and consists of the majority of vehicles in the convoy. It is the largest part of the convoy. It can be subdivided into serials and march units for easier control and management.
- The trail is the last section of a march element. The trail consists of recovery, maintenance, and medical support. The trail officer is responsible for march discipline, breakdowns, straggling vehicles, and control at the scene of any accident involving his march unit until the arrival of civilian authorities. [Figure 5-3](#), shows equipment that can potentially be included in the trail.

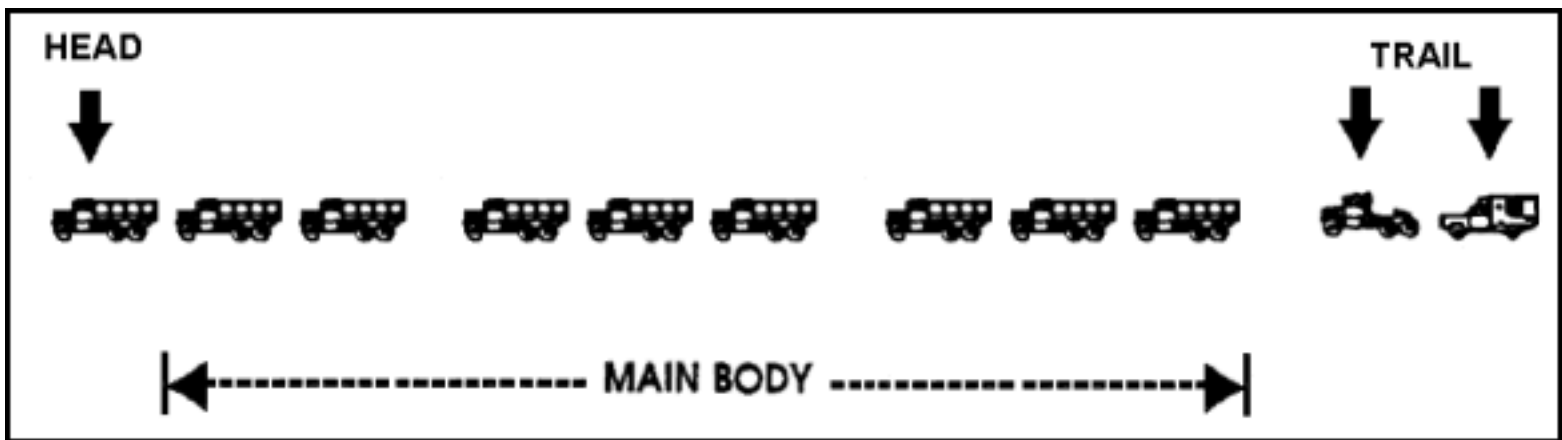

Figure 5-2. Functional Elements of a Convoy

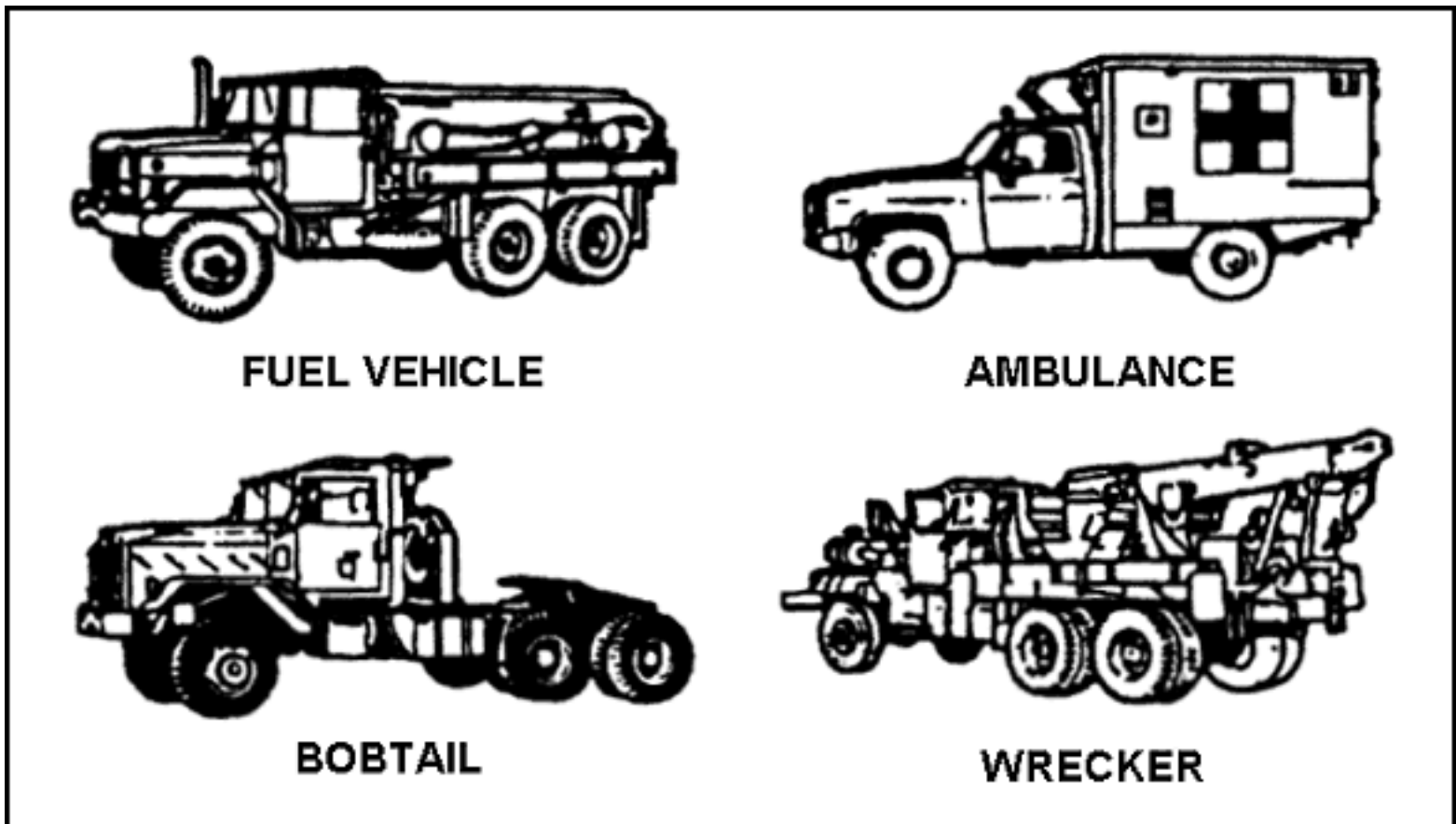

Figure 5-3. Equipment Included in the Trail

TYPES OF FORMATIONS

5-4. The convoy must be organized to meet mission requirements and provide organizational control. The convoy commander decides how the convoy is formed for movement. The three basic types of formations are close column, open column, and infiltration. They are described as follows:

- Close column provides the greatest degree of convoy control. It is characterized by vehicle intervals of 25 to 50 meters and speeds under 25 mph. Close column is normally used during limited visibility or on poorly marked or congested

roads.

- Open column is the preferred formation used during movement. It is characterized by vehicle intervals of 100 meters or more and speeds in excess of 25 mph. Open column is normally used on well marked open roads with good visibility.
- Infiltration has no defined structure. Vehicle intervals and speeds will vary. This type of formation is normally not used during movement. Infiltration should only be used as a last resort in extremely congested areas or when the mission dictates.

A motor convoy is a group of vehicles organized for the purpose of control and orderly movement with or without escort protection. This chapter provides guidance for planning, organizing, and conducting convoys. A convoy is defined as follows:

- Any group of six or more vehicles temporarily organized to operate as a column, with or without escort, proceeding together under a single commander.
- Ten or more vehicles per hour dispatched to the same destination over the same route.
- Any one vehicle, with or without escort, requiring the submission of a special haul permit.

NOTE: Dimension and weight limitations on vehicles vary greatly. Check local rules and restrictions before any military motor movement. However, for gross planning purposes, vehicles are normally considered over dimensional or overweight if they exceed the following:

Width	102 inches
Height	162 inches (13 feet, 6 inches)
Weight	20,000 pounds for single axles 34,000 pounds for tandem axles 80,000 pounds for gross weight
Length	48 to 60 feet for semitrailers

CONVOY PERSONNEL

5-5. There are certain personnel associated with military convoys. The following is a list of these convoy personnel.

CONVOY COMMANDER

5-6. Each convoy will be organized under the control of a convoy commander. Since the convoy commander must be free to supervise the movement of the convoy, there is no specified location for him in the convoy. The convoy commander should have contact with all subordinate commanders during the movement.

SERIAL/MARCH UNIT COMMANDERS

5-7. Serial/march unit commanders are positioned where they can best control their convoy element. Although commanders may want to place themselves at the head of their units, it is not recommended because this will restrict their ability to control all of their vehicles.

NOTE: Convoy, serial, and march unit commanders should avoid driving in the left hand lane because the limited speed of military vehicles can easily cause them to become a hazard to faster moving civilian traffic.

PACESETTER

5-8. The convoy commander will designate a pacesetter for the convoy. The pacesetter is in the first vehicle in the march element, normally the slowest, heaviest vehicle, excluding oversize/overweight vehicles. The pacesetter will perform the following:

- Maintain the rate of march established by the convoy commander.
- Meet all established times at SPs, critical points, CPs, and RPs.
- Inform the convoy commander of any obstacles or hazards that may cause a deviation from the established route, such as construction, detours, or other obstacles.

TRAIL OFFICER

5-9. The trail officer is positioned at the rear of a march element. He checks and observes vehicles at the SP and keeps the convoy commander informed on the status of vehicles that fall out of the convoy. He oversees all maintenance, recovery, accident investigation, medical aid, and disposition of disabled equipment. He picks up all guides and markers left by preceding march elements.

GUIDES

5-10. Guides are used to ensure the convoy follows the prescribed route and become very important when operating in an area where road signs are poor or nonexistent. They assist convoys in locating supported units, preventing conflict with other convoys, and providing information on the route. Guides should be instructed that the convoy does not have priority over civilian traffic when not on a military reservation. Guides do not have authority to disregard traffic lights or other traffic devices on public roads.

CIVILIAN POLICE ESCORT

5-11. The convoy commander should request the assistance of civilian police, whenever possible, for all critical areas not on military reservations through which the convoy will pass. These areas include the following:

- Major intersections.

- Entrances to and exits from expressways and main routes.
- Densely populated and industrial areas.
- Entrances to and exits from rest halt areas.

The convoy commander should request that the installation provost marshal arrange for civilian police support in the immediate vicinity of the installation where the convoy originates.

VEHICLE PLACEMENT

5-12. The placement of the vehicles in an organizational element of a convoy is determined by many factors. One of the major factors is the danger of rear-end collisions. To reduce the possibility of injury to personnel, place vehicles transporting troops in the first march unit of the main body of the convoy. When empty trucks or trucks loaded with general cargo are available, use them as buffer vehicles between those transporting personnel and those loaded with hazardous cargo. Other factors to consider include the following:

- Position those vehicles that require the longest unloading time near the front of the main body of the convoy. This will shorten the turnaround time.
- If the convoy consists of vehicle-trailer combinations, have one prime mover without trailer (bobtail) per 10 vehicle-trailer combinations to support the recovery operations.
- Place vehicles transporting hazardous cargo in the last serial of the convoy but not in the trail party.

CONVOY COMMUNICATIONS

5-13. Convoy commanders and NCOICs must effectively communicate with their subordinate leaders and vehicle drivers. Communications must be well planned and understood by all personnel involved in the movement. Radio is the principal means of communications within a motor convoy. It allows for the rapid transmission of orders and messages between widely separated elements in a convoy. Plans for radio use must be given in orders, in the unit SOP, and in the movement plan. Consideration needs to be given to the number of radios in the unit and distance over which elements of the convoy are trying to communicate.

5-14. Another means of communication is visual communications. These may involve hand and arm signals, flags, headlights, and protechnic signals and messages. In addition to hand and arm signals, messages may be written on a board and posted along the route or displayed by a guide in view of the oncoming vehicles. In the event of radio silence or for other reasons, the drivers or their assistants can use visual signals for convoy control. These signals should be specified in a SOP so that drivers are completely familiar with them. The signals must also be trained and rehearsed.

5-15. The next group of signals include audio signals which consists of the use of

horns, whistles, and verbal messages. When possible, serial commanders should be equipped with loudspeakers to issue verbal instructions.

CONVOY IDENTIFICATION

5-16. Convoy identification must include the following:

CONVOY CONTROL NUMBER

5-17. Each convoy is identified by its CCN, which is assigned by the ITO where the convoy originates. The CCN identifies the convoy during its entire movement. It is placed on both sides of each vehicle in the convoy. The CCN is also placed on the top of the hood of the first and last vehicles of each march element.

5-18. For active duty component units, TC-ACCIS provides the capability for preparing the [DD Form 1265](#) and [DD Form 1266](#). The ITO provides the CCN through TC-ACCIS. The CCN has 10 digits. The first two digits identify the location (post or state) from which the convoy originates. The next four digits represent the Julian date. The next three digits are the sequence number, followed by a single digit, designating the type of movement. The type of movement designators are as follows:

Outsize/overweight vehicles	- S
Explosives	- E
Hazardous cargoes	- H
All other convoys	- C

An example is FE 5234 039 C, a convoy leaving from Fort Eustis, VA, on 22 August 1995. It is the 39th convoy of the day and is a regular convoy without any special requirements.

NOTE: CCN may be different than what is described above based on command directives, HN, or STANAGs.

VEHICLE IDENTIFICATION

5-19. The first vehicle (pacesetter) in each element of the convoy must have on its front a sign with 4-inch black letters on a yellow background reading CONVOY FOLLOWS. The last vehicle of each convoy element will have on the rear a sign reading CONVOY AHEAD. CONVOY AHEAD signs are not on maintenance or medical vehicles unless that vehicle's purpose is to represent the end of the convoy. Refer to [AR 55-29](#) for the dimension of the convoy signs.

5-20. Mark each march element of a convoy with flags 12 inches in height and 18 inches in length. The lead vehicle is fitted with a blue flag and the rear vehicle with a green flag. Mount the flag on the left front of the lead and trail vehicle so that it will not interfere with the vision of the driver or with any functional component of the vehicle (see [Figure 5-4](#)).

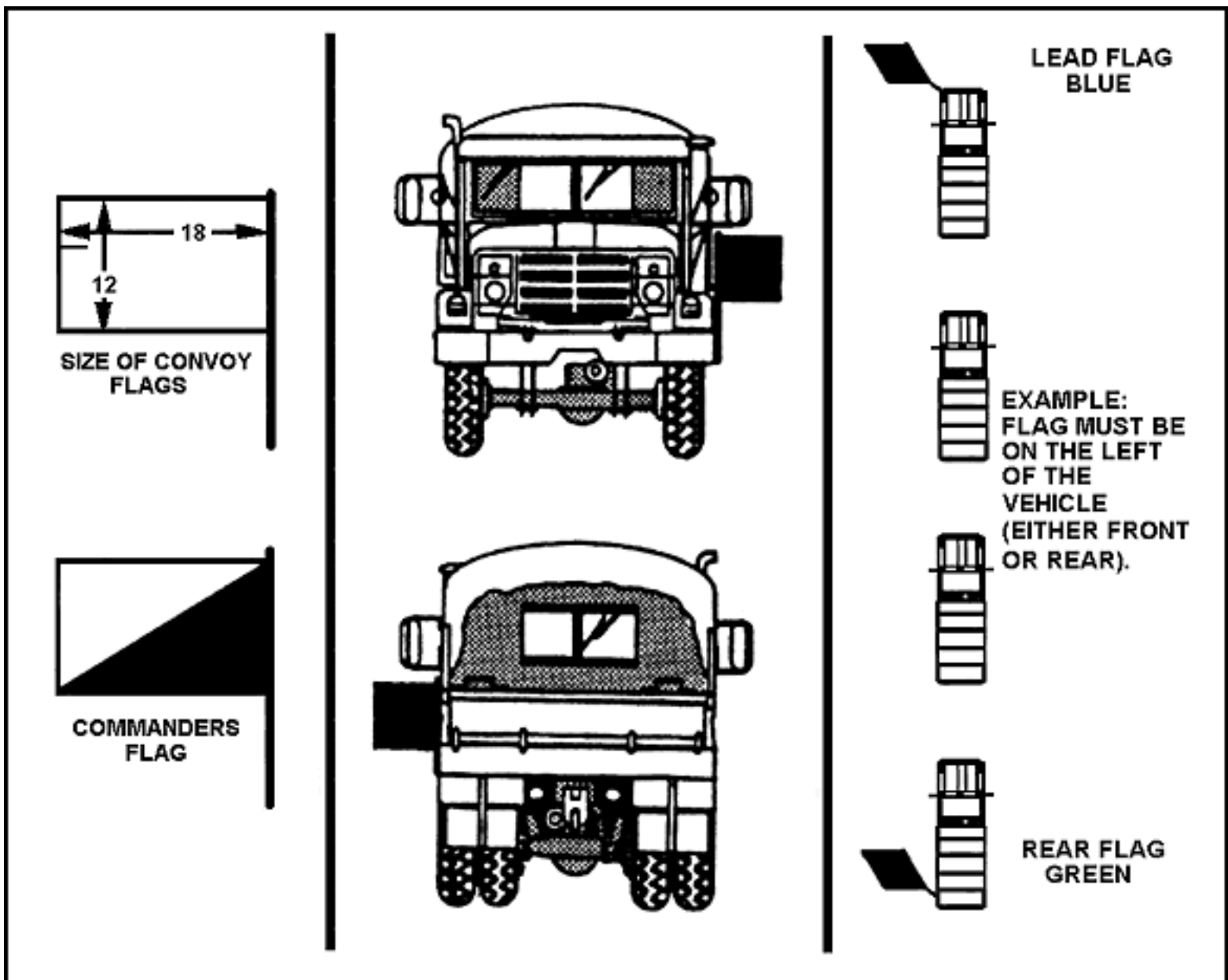

Figure 5-4. Flag Placement on a Vehicle

5-21. The vehicles of the column, serial, and the march unit commanders must carry on the left front bumper a white and black flag. Trail party vehicles will carry an international orange safety flag. Local police or MP escort vehicles will not display convoy identification flags. Convoy identification flags are available through local supply channels as follows:

- Lead vehicle flag (NSN 8345-00-543-6912).
- Last (rear) vehicle flag (NSN 8345-00-543-6913).
- Commander's flag (NSN 8345-00-543-6911).

NOTE: A standard flagstaff attachment (NSN 8345-00-242-3650) can be used for attaching the flags to the vehicles.

A rotating amber warning light will be placed on cranes (wreckers), oversize or overweight vehicles, and the first and last vehicles in a convoy. The lights will be on

at all times when the convoy is operating outside a military installation.

SAFETY EQUIPMENT AND WARNING DEVICES

5-22. While moving at night or during periods of reduced visibility, lead, trail, and oversize/overweight vehicles will operate four-way flashers. Convoy vehicles will also display reflective L-shaped symbols 12 inches long and 2 inches wide at the lower corners of the vehicle's body (refer to [AR 55-29](#)). See [Figure 5-5](#), for specifications.

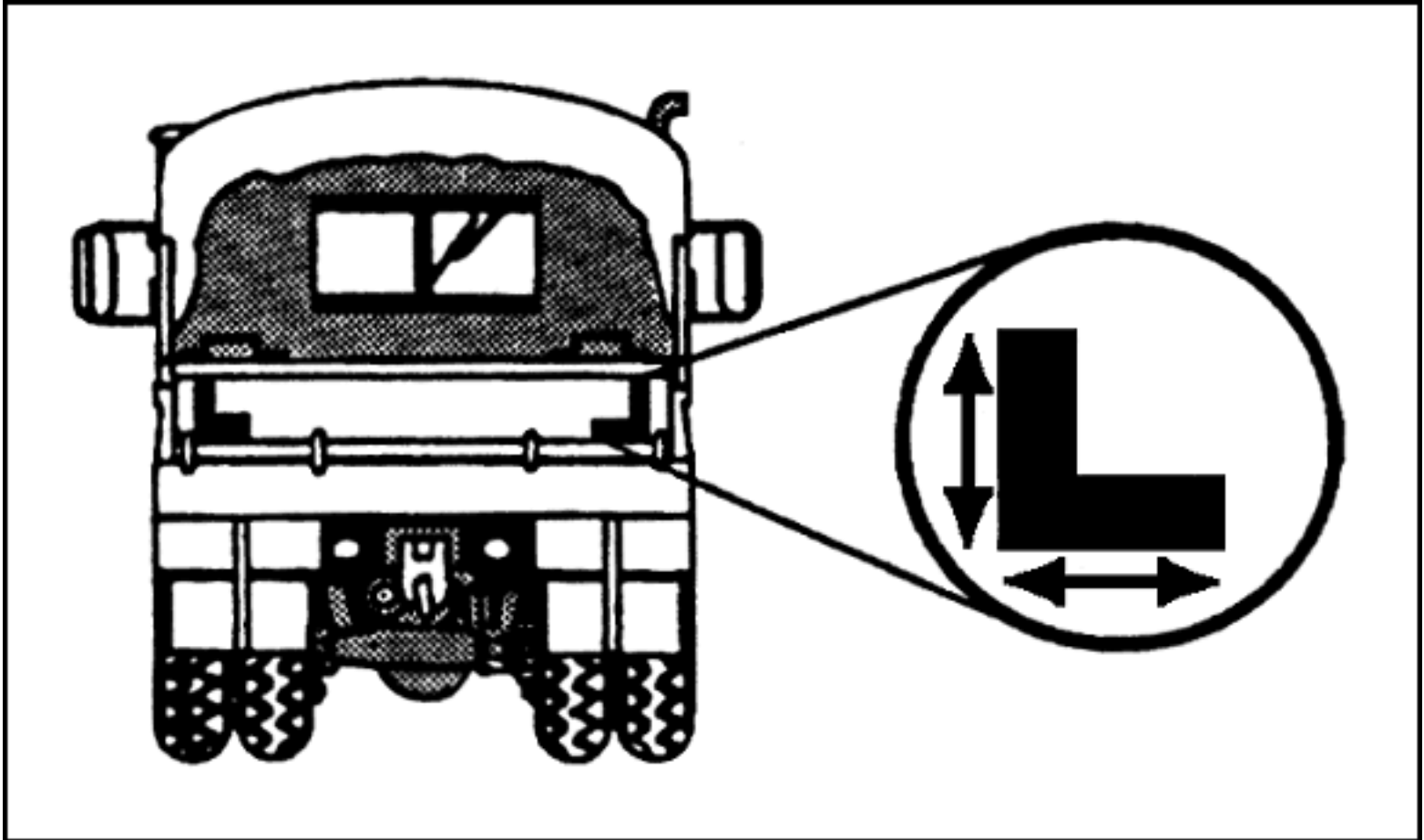

Figure 5-5. Reflective L-Shaped Symbol

5-23. Headlights of all vehicles moving in convoy or halted on road shoulders must be on low beam at all times except where prohibited by local ordinances. While halted on shoulders, vehicles equipped with emergency flasher systems must also have these lights operating. The following safety equipment is needed in all vehicles:

- An approved fire extinguisher.
- An approved first aid kit.
- One set (pair) of tire chains when snow or ice conditions may be encountered.
- An approved highway warning kit.

Road guides must wear high visibility devices such as a reflective vest (NSN 8415-00-177-4974). Baton flashlights must also be provided when the convoy

operates during darkness or when visibility is reduced to 500 feet or less.

FINAL ACTIONS BEFORE DEPARTURE

5-24. The convoy commander or his designee inspects all vehicles in the convoy staging area to ensure that they are in satisfactory condition. He ensures on-the-spot corrections are made as soon as possible. Vehicles should be checked for the following:

- Properly completed dispatch ([DD Form 1970](#)).
- PMCS completed and deficiencies and shortcomings are corrected ([DA Form 2404](#)).
- Required basic issue items.
- Check fuel levels.
- Safety equipment (fire extinguishers, first aid kit, and so on.)
- Properly secured secondary loads.
- The correct CCN, flags, signs, lights, and placards.
- Headlights on low beam.

After vehicles and drivers have been inspected and the convoy is organized and ready to move out, assemble the personnel for a final briefing. Distribute strip maps to all drivers. Use an enlarged strip map (a blackboard drawing or other drawing) to explain details of the route. Conclude the briefing with a question and answer period.

DRIVER PREPARATION

5-25. The convoy commander ensures the following:

- Drivers and assistant drivers possess a valid [OF 346](#) for the piece of equipment they are operating.
- Only experienced drivers are selected to operate vehicles on public highways.
- Drivers are prepared, are in the proper uniform, and have required equipment.
- Drivers have 8 hours of rest within 12 hours before the convoy departs (refer to [AR 55-29](#)).

The convoy commander also ensures that drivers and assistant drivers are briefed thoroughly before the convoy departs. He issues strip maps and orders to drivers and briefs the following topics:

- Convoy organization and vehicle assignments.
- Departure and arrival times.
- Compliance with traffic signals.
- Route of march.
- Maximum and minimum speeds.

- Actions at halts.
- Route and highway markers in accordance with the strip map.
- Vehicle gaps or intervals (for urban areas, expressways, conventional routes, and entrance and exit routes).

NOTE: A simple method to use is the "4 second rule." It establishes an interval of 4 seconds between vehicles in the convoy. The interval can be maintained regardless of the speed of the convoy, and it allows for the space between vehicles to be adjusted as the rate of march changes.

- Schedule rest stops and refuel points.
- Vehicle recovery operations.
- Obedience to civil authorities and MP.
- Location and time of scheduled halts.
- Action to take if separated from the convoy.
- Actions in the event of breakdown or accident.
- Refueling procedures.
- Communications/signal procedures.
- Light discipline.
- Security en route and during halts.
- Weather forecast and actions during inclement weather.
- Chain of command and locations.
- Safety during movement and during halts.

NOTE: The assistant driver will remain awake at all times and keep the driver alert. The use of an assistant driver DOES NOT double the amount of driving time for the convoy.

ROAD MOVEMENT PLANNING

5-26. All convoy movements must be planned out in advance. The following factors and formulas will assist in convoy calculations.

TIME-DISTANCE FACTORS

5-27. Time-distance factors are used to perform calculations for planning highway movements. Understanding time and distance factors is critical when planning a convoy. [Figure 5-6](#) shows the relationship between distance factors and time factors.

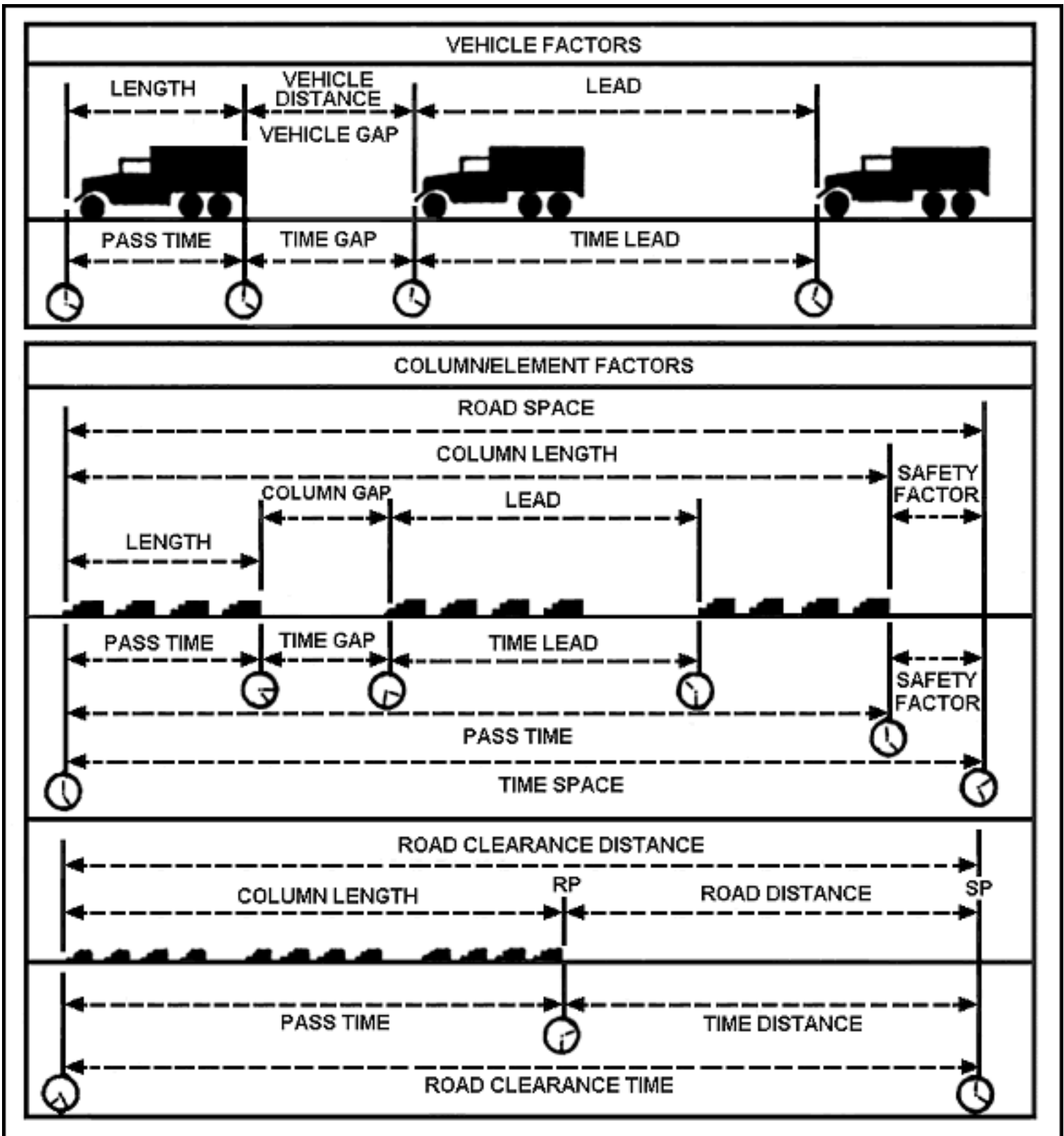

Figure 5-6. Distance and Time Factors

5-28. Distance factors are expressed in kilometers or miles. The following explains distance factors:

- Length is the length of the roadway the convoy occupies, measured from the front bumper of the lead vehicle to the rear bumper of the trail vehicle.

- Road space is the length of a convoy plus any additional space added to the length to avoid conflict with leading and following traffic.
- Gap is the space between vehicles (vehicle interval) or between elements of a convoy (column gap). It is measured from the rear of one element to the front of the following element.
- Road clearance distance is the distance that the head of a convoy must travel for the entire convoy to clear a given point along the route. It is the sum of the convoy's length and road distance.

5-29. Time is expressed in hours or minutes. The following describes time factors:

- Pass time is the time required for a convoy or a subgroup to pass a given point on the route.
- Time space is the time required for a convoy or one of its subgroups to pass any point along the route plus any additional time required for safety.
- Time gap is the time between vehicles or elements as they pass a given point. It is measured from the trail vehicle of one element to the lead vehicle of the following element.
- Time lead is the time between individual vehicles or elements of a convoy, measured from head to head, as they pass a given point.
- Time distance is the time required for the head of a convoy or any single vehicle to move from one point to another at a given rate of march.
- Road clearance time is the total time a convoy or an element needs to travel over and clear a section of road. Road clearance time equals the pass time plus time distance.

ROAD MOVEMENT CALCULATIONS

5-30. To complete a movement request, the moving unit must determine the arrival and clearance times at the SP, CPs, halts, and RP. Clearance times must be calculated for all march elements within the convoy. Use the following formula to compute the time distance of the convoy:

$$\text{Time Distance} = \text{Distance/Rate}$$

To calculate the clear times at each point along the route, planners must determine the pass time. Calculating pass time requires two calculations: vehicles per mile (density) and pass time. Use the following formula's to compute density and pass time:

$$\text{Density} = \frac{1 \text{ mile (1,760 yards)}}{\text{vehicle gap (yd) + average vehicle length (yd)}}$$

$$\text{Pass Time} = \frac{\text{number of vehicles X 60 + time gap}}{\text{density X rate}}$$

CONVOY MOVEMENT REQUESTS

5-31. Units needing to convoy must request and receive clearance before beginning movement. The request is submitted through command channels to the ITO or movement control element within whose area the convoy originates. Requests may be prepared manually or through TC-ACCIS.

5-32. Requests for convoy clearance are submitted on [DD Form 1265](#) or on a theater movement bid. A special hauling permit ([DD Form 1266](#)) is used to request permission to move oversize/overweight vehicles on public roads. All sections of the forms must be completed. The convoy commander should identify specific CPs in addition to the required location and duration of each halt. The convoy commander may also request additional support and routing instructions.

5-33. Once the convoy clearance request has been reviewed and processed by the approving authority, the unit is issued a CCN. The movement of the convoy must be conducted as the convoy clearance directs. Deviations are not authorized without prior coordination with the approving authority.

5-34. The convoy commander must ensure that the routing specified on the approved convoy clearance is followed and that the estimated time of departure and estimated time of arrival are met at each of the CPs and rest halts.

PREPARATION OF THE GRAPHIC STRIP MAP

5-35. The strip map will show a picture of the route over which the convoy will travel. The following eight items must be shown on the strip map:

- Start point. The SP is the location where the convoy must start and comes under the active control of the convoy commander. As the SP is passed, each element should be traveling at the rate of speed and vehicle interval stated in the OPORD. When selecting an SP, select a place that is easily recognized on the map and on the ground.
- Release point. The RP is the place where convoy elements are released to their owning units. It must be clearly shown on the strip map. As with the SP, the convoy passes the RP without halting and at the rate and vehicle interval stated in the OPORD.
- Halts. Scheduled halts provide rest, messing, refueling, maintenance, and schedule adjustment, while allowing other traffic to pass. Halt time is included in the road march. Generally, all elements of the convoy halt at the same time so that the time gaps between elements remain the same. Every effort should be made so that dining and refueling halts coincide.
- Convoy routes.
- Major cities and towns.
- Critical points/checkpoints. CPs are designated along the route for control and maintenance of the schedule. Choose easily recognized features as CPs.

- Distance between CPs.
- North orientation.

The strip map will be detailed but not so cluttered with information that it is unreadable (see [Figure 5-7](#)). Listed are examples of what may be shown:

- Route data, including route numbers, major intersections, and mileage between points.
- Movement control data, including arrival and departure times at the SP, CPs, RP, state lines, and all halts.
- Logistical support data, including the location of all logistical support facilities. This may also include the procedures for requesting/obtaining medical and maintenance support.

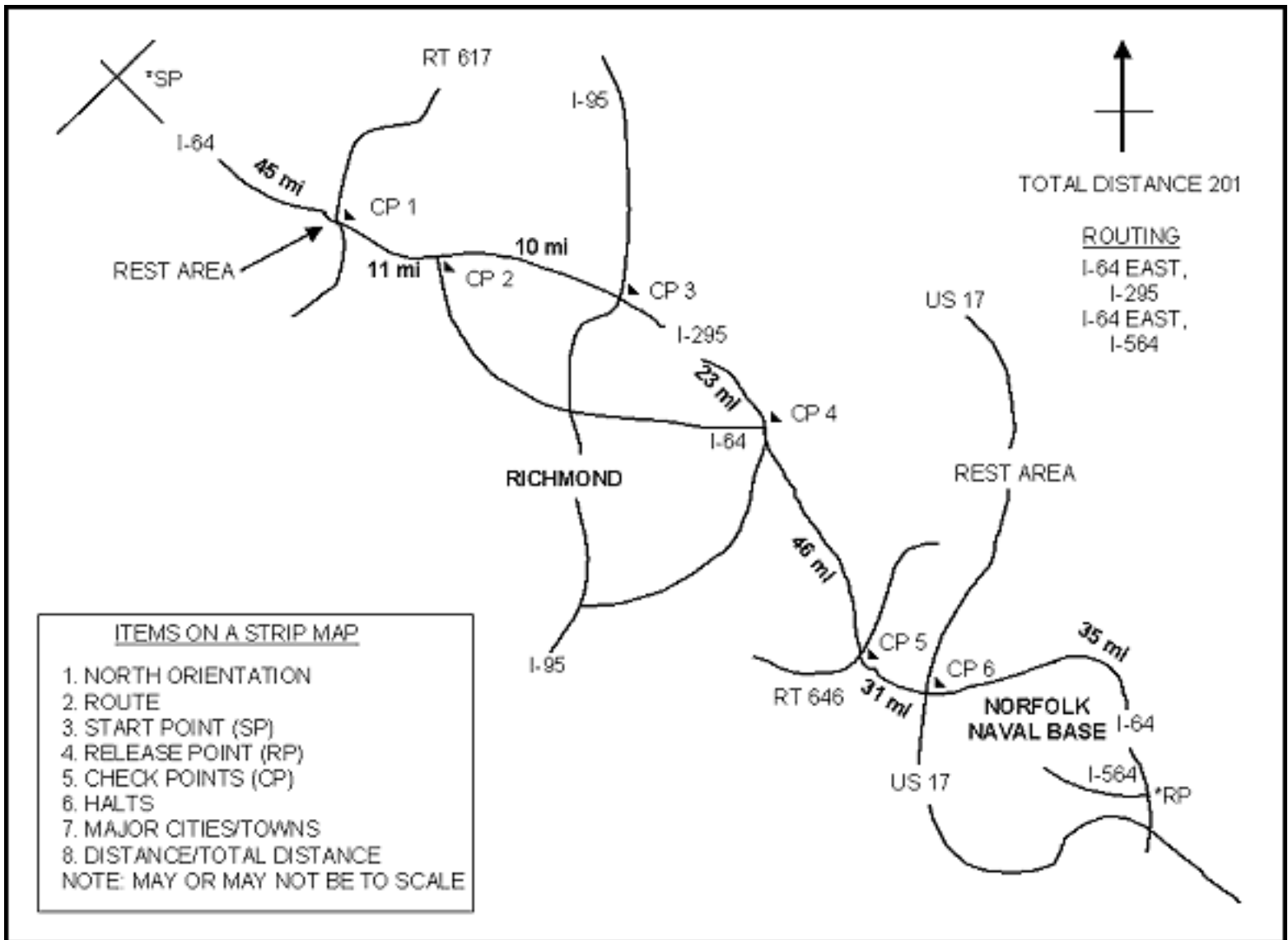

Figure 5-7. Strip Map

CONVOY EXECUTION

5-36. Convoys should depart staging or marshaling areas in sufficient time to pass the SP at the prescribed time. Convoy commanders should use the close column formation when moving from the staging area to the SP of the main convoy route.

TRAFFIC

5-37. Main convoy routes are usually characterized by heavy, fast-moving traffic. Entering the route is a critical operation, but the risk can be reduced when civilian police assist by controlling traffic.

5-38. Ensure that all vehicles remain in the right lane after the convoy has entered the flow of traffic. Where the right lane is reserved for traffic turning off at the next exit, the convoy should use the next adjacent lane. Drivers must be alert and drive defensively.

5-39. To leave the route, either to enter a rest area or to take another route, move vehicles to the deceleration lane at the earliest opportunity and reduce to a safe speed to exit. Commanders should ensure that all vehicles remain with the convoy element.

SCHEDULED HALTS

5-40. Schedule halts so that the convoy will halt for 15 minutes at the end of the first hour of operation and 10 minutes every 2 hours thereafter. Minor adjustments to this schedule can be made when a suitable area is not available at these time periods. Schedule all meals and refueling halts at the same time. Take the following precautions when halting the convoy:

- Avoid areas on curves or reverse sides of hills.
- Leave enough room to allow the vehicles to park off the paved portion of the road and return to the road safely.
- Maintain a minimum distance of 3 feet between parked vehicles.
- Do not permit convoy personnel on the traffic side of vehicles except to perform prescribed maintenance.
- Make sure drivers and assistant drivers perform prescribed maintenance and check the security of cargo.
- Post guards at least 50 meters behind the last vehicle to warn traffic when departing a rest area.
- Ensure that there is space for other vehicles. Convoy vehicles should not occupy more than 50 percent of the parking area at any time.
- Maintain a sufficient time gap between serials to allow one to clear a rest area before the following serial arrives.

UNSCHEDULED HALTS

5-41. Move a disabled vehicle immediately from the traffic lane to a location where it will not be a hazard to other traffic. If a breakdown occurs, emplace a highway warning device either in the obstructed lane or on the shoulder of the road if the vehicle is on the shoulder. Do this before any attempt is made to repair the vehicle. DO NOT use military personnel to warn traffic by manual flagging except where warning devices do not give adequate warning.

5-42. In the event of an accident, make every effort to minimize its effects and keep the convoy moving. Do the following if an accident happens in the convoy:

- Keep moving. Only the vehicle immediately behind the vehicle should stop and render assistance.
- Give first aid. Give immediate attention to injuries.
- Report any accident to civilian police and wait for assistance. Do not move the damaged vehicle until an accident investigation has been completed by civilian police.
- Trail parties will assist civil authorities, investigate, and recover the vehicle as required.
- Clear the traffic lane. The crew of the affected vehicle should make every effort to clear the traffic lane as soon as possible.
- Complete an [SF 91](#).

The first officer or NCO to arrive at the scene of the accident will take charge by supervising emergency aid, directing military traffic, warning civilian traffic, and directing the placement of warning devices until the trail officer arrives. The trail officer, aided by available medical and maintenance personnel, will supervise and direct care of the injured and disposition of the damaged vehicles. Further assistance needed should be requested from the agencies listed in the convoy OPORD.

MOVEMENT REPORTS

5-43. The convoy commander will normally provide a movement report to the next higher HQ. During deployment and selected exercises, special instructions included with the approved convoy clearance will direct the convoy commander to report to the appropriate HQ upon departure, at selected halt locations, and upon arrival. As a minimum, the report should contain the following:

- Convoy clearance number and convoy commander's name.
- Time of arrival at scheduled halts.
- Time of arrival at state lines or country borders.
- Complete details and circumstances of any accident or incident.

[RDL](#)[Table of](#)[Document](#)[Download](#)[Homepage](#) [Contents](#) [Information](#) [Instructions](#)

Chapter 6

Rail Movement Operations

This chapter provides guidance for rail planning and loading. This includes loading, blocking, and bracing military equipment on railway cars for movement within CONUS according to applicable loading rules. Railcar loading procedures in overseas areas are dictated by the HN carrier and published in local command directives.

RESPONSIBILITIES

6-1. The unit and the installation have planning and execution responsibilities during rail operations. The following is a list of these responsibilities.

DEPLOYING UNIT

6-2. Unit commanders or shippers submit movement requirements to the supporting ITO. Units are responsible for preparing their equipment for rail loading. This includes packing, crating, banding, blocking, and bracing secondary loads. Units load railcars under the technical supervision of the ITO. Army terminal units or DSBs may assist units during rail loading. The ITO is ultimately responsible for approving rail loads. Deploying units will use the following publications as guidance for railcar loading:

- [FM 55-17](#).
- [TB 55-2200-001-12](#).
- [MTMCTEA Pamphlet 55-19](#).

Direct questions arising during rail loading that are not answered in these publications to the ITO. The ITO will coordinate with the railroad representative or the MTMCTEA to resolve the issue. MTMCTEA publishes transportability guidance for specific vehicles in the Army inventory system.

INSTALLATION TRANSPORTATION OFFICER

6-3. The ITO orders railcars in the types and quantities required based on the deploying unit's movement requirements. He will compute railcar requirements based on the shipping configuration of the items to be shipped. Accurate AUEL/DEL data is essential. The ITO will make maximum use of the available loading space to make the most efficient use of the assets and to reduce the carrier's transportation charges.

6-4. The ITO is the official liaison with MTMC and the railway agent. He inspects all railcars for serviceability before units begin loading. He provides technical advice to units on BBTM. He ensures that rail loading schedules are maintained according to the movement order. The ITO provides HAZMAT documentation as required. In conjunction with the railway agent, he checks applicable route clearances for each shipment of overweight or oversized items.

6-5. The ITO can use TC-ACCIS to prepare the GBL based on equipment data from the deployment equipment list. This information is obtained by scanning the military shipment labels using portable bar code readers. The scanned information is used to prepare the GBL and provides ITV.

DIRECTOR OF PUBLIC WORKS

6-6. The DPW provides units blocking and bracing materials needed to load military equipment on railcars. Units must request these materials from the DPW as far in advance as possible. The DPW also provides tools and assistance as required. At Army depots, the shipping activity or responsible supply agency may furnish these materials and services according to local organization and command policies.

RAIL EQUIPMENT

6-7. Units may deploy on DODX or commercial railcars. The types of railcars vary from carrier to carrier. There are three basic types of cars:

- Open top cars (flatcars and gondolas). These cars vary in length, but military-useful flatcars are 60, 68, and 89 feet long. The cargo requirements determine the type and size of the railcars to be ordered.
- Closed cars (boxcars).
- Specialty cars, such as multilevel, caboose, and heavy-lift; and TOFC.

6-8. Railcar capacities are defined by size and load limits. All railway freight cars in CONUS have the car number, length, width, and height (closed cars), capacity, lightweight (weight of the car empty), and load limit in pounds stenciled on the side.

6-9. The preferred type of flatcars for deployments are chain-equipped flatcars. They usually reduce the need for blocking and bracing material, reduce loading times, and reduce line-haul transportation costs.

6-10. Flatcars without side rails are easier to load. Vehicles wider than the railcar deck can be easily accommodated. This is particularly true for tracked vehicles. Side rails impose limitations on what can be loaded.

6-11. ITOs should first consider using DODX if available. DODX provide more flexibility in loading and unloading and eliminate the additional (demurrage) charges that can accrue on commercial railcars. If DODX are used, ITOs will report the movements to the MTMC area command.

RAIL SITE PREPARATION

6-12. The rail site must be clean, free of debris, and well lit. Position railcars to reduce the length of the gaps between railcars. Apply car brakes and chock rail wheels to prevent shifting during loading. The ITO inspects railcars for cleanliness and serviceability. Additional site preparation may include setting up command and control facilities, warming tents, and medical aid stations. When possible, turn off overhead electric wires.

6-13. Check chain tie-downs and position them on the railcar decks to avoid having to reposition chains after vehicles are loaded. Store unused chains in the channels to prevent damage. Place spanner boards between railcars when loading wheeled vehicles. As a general rule, at least 12 inches of the spanner should overlap the railcar deck. Most tracked vehicles do not require the use of spanners when rail loading. The ITO will provide spanners as required for rail operations. Spanners come in various lengths to meet operational requirements.

RAIL LOADING

6-14. The following are essential principles of loading, blocking, and bracing vehicles on flat cars or in boxcars:

- Cars must be suitable for safe transportation of the load. This is determined by a joint inspection between the ITO, the using unit, and the rail representatives when the empty cars arrive.
- Load and weight limits must not be exceeded.
- Loads must not exceed the width and height restrictions over the proposed route.
- Loads must be adequately secured on cars.

The railroads prescribe loading and tie-down requirements based on the load and type of railcar. The ITO will assist in determining the proper loading method. See [Appendix C](#) for equipment preparation standards and [Appendix D](#) for hazardous loads.

LOADING RULES

6-15. The AAR publishes loading rules that apply to both the railroad and the ITO or shipper. These rules are incorporated into military publications. This means that a railroad can refuse to accept an improperly loaded shipment and the ITO or shipper can refuse a car that they find unsuitable for the planned load. However, once the military accepts the car, units have full responsibility to comply with the AAR rules.

RESTRICTIONS

6-16. Restrictions on loading include the following general rules:

- Do not exceed the load limit of the car.
- Do not exceed one-half the load limit of the car on any axle.
- Balance the load on the car.
- When loading large and heavy items not otherwise covered by rules, load them with the largest dimensions and heaviest weight on the floor to prevent tipping.
- Secure items having a high CB to prevent tipping while in transit.
- Use idler cars when loads extend beyond the end of the loaded car.
- Do not place heavy equipment on trailers. This makes the load top heavy.

RAILCAR INSPECTIONS

6-17. When railcars arrive on the site, the ITO performs a joint inspection with the representative of the rail carrier before the railcars are placed at ramps or warehouses for loading. Another inspection is made after the railcars are loaded to ensure that the contents are loaded, blocked, and braced to comply with the applicable Army directives and AAR loading rules.

6-18. Details of the required inspections are discussed below. The ITO has a complete set of AAR rules and loading diagrams on file in his office that unit commanders and shipping activities may consult for guidance at any time.

6-19. During preloading inspections, check to ensure the following:

- On closed railcars, doors and fastenings are in good condition and operative. Roofs and sheathing are sound and tight, walls free of nails, and so forth. Interiors are clean and dry with floors intact.
- On open railcars, decks are free of residue or refuse from previous loadings and from foreign matter likely to damage cargo such as bolts, nails, and old blocking materials.
- On chain railcars, chains are present and serviceable. Decks must be free of residue or refuse and all wood decking is intact.

After loading inspections, check to ensure the following:

- Loads are evenly distributed (half the weight over each car truck if possible).
- Load limits are not exceeded.
- Cargo is adequately secured by blocks, braces, cables, and chains according to AAR loading rules.
- The height and width of the load is within the clearance limits of the railroads over which it is to be moved.

RESTRAINING MATERIALS

6-20. Properly applied tie-down devices are used to prevent load shifting as the train starts, stops, traverses curves, and runs over crossings and switches and loose rail

joints. Tie-down devices are included on chain-equipped cars. They are not included on older wooden deck cars. For wooden deck cars, motion is controlled as follows:

- Lengthwise motion of vehicles and similar equipment is controlled by nailing chocks against the wheels. Drive nails in wheel chock blocks at right angles to the floor.
- Lateral motion is controlled by nailing side blocks of 2 X 4 lumber of suitable length against the wheel. Chafing of tires against the side blocks is prevented by nailing burlap, fiberboard, or other suitable waterproof barrier material under the blocks and extending it a minimum of 2 inches above them.
- Vertical motion is controlled by wire cable, usually attached to stake pockets.

LOADING VEHICLES ON RAILCARS

6-21. The most common and expeditious method of loading vehicles is called the circus method. This method uses flatcars as a roadbed with spanners placed between cars. Tracked vehicles may be loaded without spanners.

6-22. After the loading sequence for the train has been determined, the vehicles are staged in that sequence. They are then called forward to the ramp and driven onto the flatcars.

6-23. A guide should be stationed on the ramp and a guide stationed on each flatcar to direct vehicles and aid the drivers. A guide should also be stationed at each side of the flatcar near the spanners. His duty is to move the spanners so the distance between spanners conforms to the wheel width of the particular vehicle. When heavy equipment is loaded, spanners are secured to each car to prevent movement.

6-24. Brake wheel clearance on loaded open-top cars is prescribed by Rule 2, Section 1, AAR Rules Governing the Loading of Commodities on Open-Top Cars. Sufficient space must be provided around the brake wheel on open-top cars to ensure accessibility.

UNLOADING RAILCARS

6-25. Railcars must be off-loaded promptly at destination so they can be returned for further use and avoid payment of demurrage or detention charges. Tariffs usually allow 48 hours free time for unloading commercial railcars. DODX will not be detained by ITOs more than 10 days without prior approval of MTMC. Blocking, dunnage, and banding must be removed from unloaded cars before releasing to the carrier.

[RDL](#)[Table of](#)[Document](#)[Download](#)[Homepage](#) [Contents](#) [Information](#) [Instructions](#)

Chapter 7

Operations at the Point of Embarkation

Units may pass through two types of ports of embarkation (sea and aerial) en route to the theater of operations. This chapter describes operations at both ports.

SECTION I - Sea

7-1. Units deploy equipment and supplies by sea through a port that is generally commanded or contracted by MTMC. Where MTMC does not have a TTBde or other contractual agreements, the Army has terminal units that can operate the seaport facilities until MTMC can negotiate HN/commercial contracts or establish a TTBde to perform this mission.

7-2. All ports must have assured communications and be able to provide ITV of unit equipment during this phase of movement. This capability must extend to providing advance arrival information to the POD.

RESPONSIBLE AGENCIES

7-3. The following is a list of agencies responsible for operations at the port of embarkation.

MILITARY TRAFFIC MANAGEMENT COMMAND

7-4. MTMC directs deployment of units and sustainment through POEs according to the TPFDD. Deploying units receive their port call instructions from MTMC. The port call message identifies what date the unit must arrive at the SPOE for movement processing. MTMC will schedule units to arrive at the POE in sufficient time to allow processing and loading to meet vessel sailing schedules. Units backward plan for SPOE movement through the ITO, and coordinate movement schedules with MTMC. MTMC is the worldwide common user ocean terminal port operator. Its deployment duties and responsibilities are as follows:

- Select unit SPOE/SPOD with the CINC.
- Determine movement requirements and coordinate vessel selection with MSC.
- Prepare and issue port call messages.
- Receive PSAs from supporting installations and direct their functions and activities.

- Receive, stage, and transship unit equipment in the port.
- Establish and direct port communications, safety policies, and physical security procedures.
- Regulate military traffic within the port.
- Direct DSBs to assist deploying units.
- Assist ITOs and traffic managers in shipping unit equipment and supplies to the POE.
- Develop stow plans, supervise vessel loading, inspect vessel readiness, and provide documentation.

MTMC TIGER TEAM

7-5. The Tiger Team opens and temporarily operates a SPOE until the TTBde is fully operational. When alerted, the Tiger Team immediately deploys to the SPOE to coordinate contracts, set up operations, and begin to receive cargo. The team will also plan for traffic flow, obtain waivers and clearances, establish liaison with the deploying unit, develop prestow plans, and provide reports. Liaison with the deploying unit is especially critical to establish the flow into the port based on the priority of load. The team's composition is determined by the team chief based on mission requirements. Command authority remains with the team until the TTBde commander arrives and assumes command.

TRANSPORTATION TERMINAL BRIGADE

7-6. TTBdes are RC units that allow the MTMC to expand the number and capability of seaports. They normally take over responsibility for port operations from the Tiger Team. TTBdes conduct ocean terminal operations at established ports where existing manpower, equipment, and infrastructure are available. When operating in CONUS, TTBdes are assigned to MTMC. They may be deployed OCONUS to expand the number and capability of ports for sustainment or redeployment purposes.

7-7. TTBdes consist of soldiers and systems. They depend on the infrastructure of the port facility, contract stevedores, and HNS at the terminals where they are assigned to operate. A typical TTBde operates two or three berths simultaneously (four or five berths for limited surge periods), provides traffic management, and supervises contracts. It employs Army standard management information systems such as ICODES, WPS, and LOGMARS. Its major responsibilities are as follows:

- Establish and maintain liaison with port authorities.
- Establish and maintain liaison with the PSA, the supporting installation or ASG, and the marshaling area commander.
- Receive, load/discharge, and transship cargo according to supported command directives.
- Establish and maintain liaison with the local MSCO.
- Prepare and update port terminal operations plans.

- Analyze terminal work load capabilities and quantify missions that may be performed by contract, HN, or military stevedore support.
- Assign unit assets, whether assigned, attached, or contracted, to accomplish terminal missions.
- Analyze, plan, and control terminal cargo movements through the terminal.
- Prepare and update vessel stow plans.
- Plan vessel work loads.
- Execute port security plans in coordination with the Coast Guard.
- Develop, process, and execute commercial contracts to hire stevedores. The civilian stevedore company provides vessel/terminal work. It normally will hire gangs to do the actual loading and lashing.
- Compile cargo receipt and processing data in automated systems for documentation, management information, and ITV.
- Perform liaison with deploying units.
- Coordinate all cargo activity and stow plans with the vessel master or his representative.

TRANSPORTATION COMMAND (TERMINAL)

7-8. The transportation commands that performs terminal service missions includes the following:

Group Level

7-9. HHC transportation group (terminal) may command two to six transportation battalions (terminal services) performing LOTS and/or fixed-pier operations. With a contracts supervision detachment assigned, the group may perform a role similar to the TTBde in that the group may administer contract and HN terminal service operations support.

Battalion Level

7-10. Terminal service battalions, crane and automated cargo accounting detachments, and various lighterage companies, load and discharge cargo in either LOTS (discharge two vessels simultaneously) or fixed-pier operations (discharge two to four vessels simultaneously) without the need for external stevedoring assistance.

Company Level

7-11. Terminal service and cargo transfer companies load/discharge cargo in either LOTS or fixed-pier operations.

7-12. Depending on the maturity of the AO, TOE transportation commands performing terminal service missions may transition to a MTMC activity. This transition will be predicated on the CINC and/or MTMC obtaining contract/HNS for

seaport operations. As contracts and HNS agreements take effect, TOE transportation commands assume COR responsibilities and, upon order, shift these missions to MTMC. Transitional procedures are coordinated between the CINC's principal port representative and MTMC.

US COAST GUARD

7-13. The USCG is responsible for all waterside physical security. This includes harbors, channels, approaches, and vessels that are in these areas. The USCG physical security plan is integrated with the port commander's physical security plan for developing and maintaining comprehensive physical security and antiterrorist plans. In addition to waterside physical security, the USCG's other duties include the following:

- Regulating the shipping, handling, and pierside storage of hazardous cargo.
- Interfacing between HN and military authorities on storage and handling of hazards, as the senior DOD port safety agent.
- Issuing hazardous cargo permits.
- Supervising vessel fire prevention programs.

PORT SECURITY COMPANY

7-14. Port security is a port commander responsibility. Availability of existing port security elements determines whether the port commander deems augmentation is necessary. A PSC may be required to augment existing port security elements.

7-15. The PSC works for the physical security officer, HHD, TTBde, or physical security officer within the S3 section of a transportation battalion (terminal service) or group (terminal). The PSC administers the port commander's physical security plan and coordinates with USCG for an integrated port physical security plan. PSC duties include the following:

- Augmenting existing port security force or controlling port traffic circulation, to include port points of entry.
- Providing escort and security for high priority shipments.
- Conducting physical security surveys and inspections and ensuring existing safeguards protect sensitive, classified, or critical materiel and supplies.
- Establishing liaison with area police authorities. Coordinating internal and in-transit sensitive and classified physical requirements as needed.

PORT SUPPORT ACTIVITY

7-16. The PSA is a temporary military augmentation organization comprised of personnel with specific skills that aid the port commander in receiving, processing, and clearing cargo at both SPOE and SPOD (see [Table 7-1](#)). CONUS installations are delegated specific ports to which they must provide support. This includes the PSA and associated logistic support for deploying units. In a mature AO, OCONUS, the

ASG provides PSA and associated logistic support for deploying units. In an immature theater or where assigned theater forces are inadequate, the ASG provides logistics support for deploying units. The deploying force provides the PSA support that augments the port commander's terminal operations force.

Table 7-1. PSA Mission Essential Task List

COLLECTIVE TASK	SUPPORTING TASKS
1. Report to the port commander, who provide command and control for his task organization.	Develop, in conjunction with the sport commander, an MOU that identified all support and installation components.
2. Receive and stage unit equipment in SPOE/SPOD staging area.	Tailor PSA to the type, size, and mode of transportation of units passing through the port.
	Implement and refine the traffic flow and the staging area to be used for each ship.
	Implement and plan for the handling and storage of hazardous, controlled, sensitive, and pilferable cargo.
	Supervise the staging and movement of all cargo.
	Stage equipment to execute stow plan.
3. Correct configured equipment and cargo POM deficiencies not resolved in the marshaling area.	Check to ensure hazardous cargo is labeled properly with HAZMAT documentation and stored according to CFR 49 .
	Check to ensure secondary loads are properly blocked, braced, and secured.
	Ensure equipment is properly documented.
	Adjust fuel to the proper level in vehicles and equipment being shipped.
	Correct cargo lashings and height limitations of equipment.

4. Serve as vehicle operators for all types of equipment to move vehicles in staging area and, if necessary, assist in loading and unloading the vessels.

Ensure properly licensed vehicle operators are available for the types of unit equipment being staged.

Implement a training program to develop skills necessary to maneuver vehicles in tight spots found on vessels.

Operate all vehicles with applicable safety procedures to include sufficient ground guides and safety equipment.

5. Assist in servicing self-deploying aircraft to include air traffic control, fire protection, fueling/defueling, and disassembly.

Assist the aircraft maintenance teams in preparing, storing, and moving aircraft to be loaded.

Supervise designated staging area landing zones and serviceability of both for aircraft support operations.

6. Provide necessary DS maintenance to ensure vehicles are able to move under their own power or recover them in the SPOE/SPOD staging area.

Perform emergency repairs (DS maintenance) on equipment in SPOE/SPOD staging area.

Provide sufficient assets (drivers and mechanics) to expeditiously load and unload deadlined equipment.

Provide vehicle recovery in SPOD/SPOD staging area during loading and unloading.

7. Assist the port commander with cargo accountability in the SPOE/SPOD staging area.

Document each movement of cargo as required by the port commander.

Provide processed equipment information/list to appropriate agency at the times requested.

Train documentation personnel on documentation being used.

8. Provide for security of sensitive (protected) and classified cargo.
- Enforce hazardous and sensitive cargo procedures established by the port commander.
- Establish control procedures that deny unauthorized access to hazardous and sensitive cargo.
- Establish procedures to protect classified and OPSEC information.

NOTE: A general numeric sizing rule of thumb for this PSA task force is a company for a deploying brigade, a battalion for a deploying division, and a brigade for a deploying corps. This relates to size only, not organizational structure.

7-17. Commanders responsible for deployments should not (where practical) allocate deploying units to operate the PSA organization. The JPEC should allocate separate elements to perform this function. Commanders responsible for PSA organizations should maintain the same core personnel for the duration of the deployment and augment, as required, with unique deploying unit skills such as aviation personnel and munitions experts. Terminal operations success depends on a well-organized PSA augmenting and supplementing the port commander's SPOE/SPOD mission.

7-18. The PSA is under operational control of the TTBde/port commander. It will be established (through agreement with appropriate MACOM) by supporting installations and contract labor. An ISA between the support installation and the terminal commander will identify the PSA support requirements. The port commander will request additional PSA support requirements not originally identified in the ISA.

7-19. The PSA establishes the necessary communications to ensure the proper flow of cargo. It provides daily operational reports of cargo received, maintenance performed, and operational problems to the port commander.

7-20. In areas designated by the port commander, equipment will be staged according to the stow plan and call forward schedules. Vehicles will be manifested by like type if a prestow plan is not available.

7-21. The PSA organizational functions (see [Figure 7-1](#)) depend on the port commander's SPOE/SPOD mission, available contract and HNS, and the TOE and/or TDA organizations performing the terminal operations mission. PSAs are tailored to perform terminal operations duties that cannot be performed by assigned/attached, contract, or HNS elements.

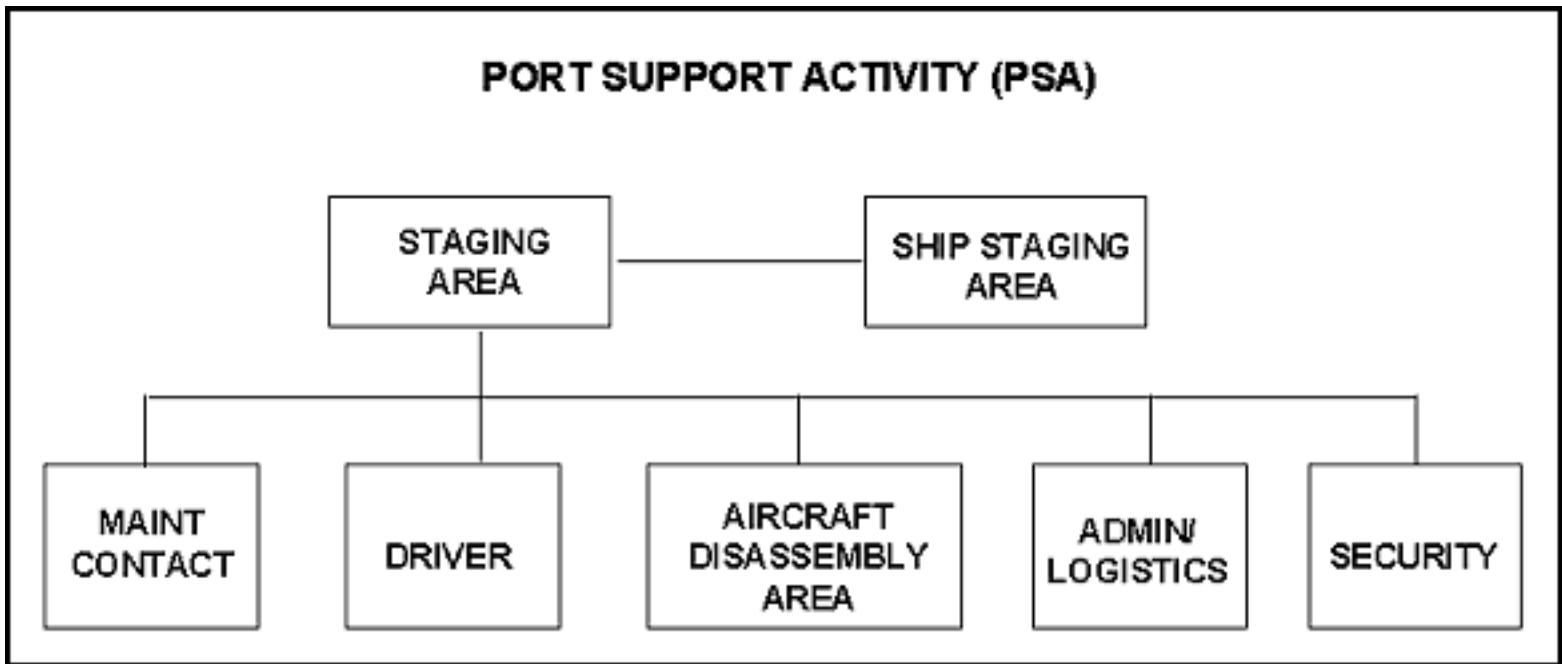

Figure 7-1. PSA Organizational Chart

7-22. The PSA must establish a command structure that is tailorable to assist in any situation and provide trained personnel to accomplish its mission. The unique equipment assigned to engineer units and personnel who operate this equipment make this unit one of the most desirable units to perform PSA missions.

7-23. The commander providing PSA support should first consider the type of unit and equipment being deployed. He then selects personnel with the following qualifications and skills:

- Personnel qualified to handle the physical security on classified equipment and cargo.
- Personnel with unique equipment operator skills.
- Maintenance personnel to correct primary weapon system and deploying equipment deficiencies.

7-24. The PSA's day-to-day contact with the port commander is through the logistics and PSA coordinating officer, HHD, TTBde, or S3 of the respective TOE transportation command. The PSA duties include the following:

- Receiving, inspecting, and documenting deploying cargo.
- Correcting cargo deficiencies that preclude sea movement.
- Operating unique equipment (normally neither contract nor military stevedores can operate track vehicles and other atypical military cargo).
- Providing backup organizational and limited DS maintenance for deploying units.
- Providing physical security guard force for staged military cargo.
- Providing blocking/bracing personnel and tools to secure secondary loads.
- Providing recovery vehicles, buses, carry-all vans, administrative vehicles,

maintenance trucks, ambulances, and equipment to wash equipment on redeployment.

- Providing workers with safety equipment, such as vests, lights, gloves, and goggles.
- Moving deploying unit equipment according to the port traffic plan.
- Providing messing/billeting and medical support to transiting units.
- Providing miscellaneous administrative support.

MARSHALING AREA

7-25. In the MOU between FORSCOM and MTMC, support installations are tasked to establish a final en route marshaling area, if space permits. Here unit equipment is to be configured for overseas movement prior to entering the port staging area. This marshaling area is designated by and under the control of the support installation and will serve to facilitate planning for the call forward of equipment.

7-26. The loading and discharging of vessels is dedicated to rapid, efficient, and controlled movement of cargo between vessel and shore. Improvements in cargo packaging, particularly containerization, contribute immeasurably toward increasing ship and cargo handling productivity. The cargo marshaling yard is an essential part of this shoreside operation providing a place to hold and process cargo pending further movement. Commanders may also select the marshaling area as an area to prepare vehicles and supplies for nontactical or combat loading.

7-27. Using a marshaling area allows rapid clearing of the beach or pier and makes vessel working space available for its primary purpose. It reduces pier congestion, thus reducing the potential for work slowdowns or stoppages in upload/discharge operations. Ideally, containers and other cargo should go from vessel's hook directly onto line-haul equipment for movement inland. This is not possible except for selected container or other cargoes. Conceptually, all cargo should move through the terminal without delay. However, this is not always possible because of the following:

- Damaged containers may require repair or restowing of contents before further movement.
- Containers may require segregation by destination or priority.
- Retrograde containers must be cleaned and inspected, where required.
- Containers found with broken seals or apparent pilferage must be inventoried and a new seal applied before onward movement.
- Frustrated cargo will be segregated to a holding area pending resolution of documentation or mechanical problems.
- Containers loaded with HAZMAT have been stuffed, documented, or placarded incorrectly.

7-28. The container marshaling yard is a temporary in-transit storage area. It allows for expeditious discharge operations by facilitating rapid, continuous movement of

cargo and/or containers to or from the beach or pier. Marshaling cargo allows leveling of line-haul peak work loads resulting from discharge operations. Marshaling cargo allows selective, controlled, and flexible phasing of container or cargo movement to destination or vessel. In container operations, the marshaling yard provides an area for the following container activities:

- Maintenance, repair, servicing, and inspection.
- Unstuffing/stuffing.
- Documentation and accountability.
- Cleaning and decontamination.
- Marshaling for retrograde movement.
- Staging.
- Security.

NOTE: [STANAG 2926](#) ensures that national containerization procedures are compatible and interoperational. This STANAG also includes factors relating to container selection, handling, inspection, and stuffing.

7-29. There is no set organization or physical layout for a marshaling area. It is organized to meet operational requirements within available space by grouping related functions. Cargo can be subdivided into any number of categories. The categories and the volume of cargo in each category plays a significant role in the marshaling area. The following are the most widely used categories:

- General (break-bulk).
- Containerized.
- Roll-on/roll-off.
- Special (oversize, heavy lift, hazardous, and security) cargo.

7-30. Cargo and container marshaling areas should provide for the following activities and functions:

- A central control and inspection point with multiple lanes for cargo and containers entering or exiting the marshaling yard.
- Auxiliary internal CPs for containers and cargo entering the yard from a beach, a rail spur, or by helicopter to a landing zone within the yard.
- Segregation of inbound containers and cargo by size and type and, within these groupings, further segregation by priority, destination, and special handling (security, mail, hazardous, and so forth).
- Segregation of retrograde cargo and containers by type and size with empty and loaded containers further segregated.
- Maintaining an inventory of containers by location and status.
- Security area for break-bulk cargo or containerized protected cargo.
- Electrical outlets for refrigerated containers. (In an unimproved or bare beach LOTS environment, self-contained refrigeration units may be needed. This

mandates separate propane or diesel refueling areas.) Refrigeration maintenance must also be provided.

- Sheltered facilities for inventory and control, documentation, and movement control elements.
- Covered facilities for stuffing and unstuffing containers.
- A traffic circulation plan showing movement flow into, through, and out of the marshaling area.
- Cleaning and/or decontamination of retrograde containers and vehicles.
- Minor repair of damaged containers.
- Equipment parking.
- Unit maintenance of equipment.
- Messing and comfort facilities.
- A spill contingency plan including emergency supplies and equipment for isolating disposing of HAZMAT spills.
- An emergency response plan for fire or other emergencies. In addition to the space for temporary storage of containers, there should be space for any container repacking requirements, container repair, or other operational or administrative functions. Space requirements are influenced by type, size, and number of containers handled, length of time containers are held in the marshaling area, and CHE available.

7-31. The marshaling area (general cargo, container, or both) is located as near the vessel, rail, air, or truck discharge or load site as practicable. Enemy capabilities and activities may require dispersion of activities or affect selection of marshaling yard location.

7-32. Cargo should be transferred mechanically when supplies are unitized and MHE is compatible with the carriers. For planning purposes, personnel requirements for mechanical handling of cargo by such equipment as RT forklifts, cranes, and tractor trailers is usually limited to an operator for each piece of MHE, a checker, and appropriate supervisory personnel.

STAGING AREA

7-33. As the vessel readies for loading, equipment is sent from the marshaling area or installation to the staging area by the port commander based on a call forward plan. The MTMC port commander assumes custody of the cargo in the staging area. The PSA performs its functions, such as driving vehicles and correcting deficiencies, in the staging area. Equipment is then loaded onto the vessel. Notional seaport operations are shown in [Figures 7-2](#) and [7-3](#).

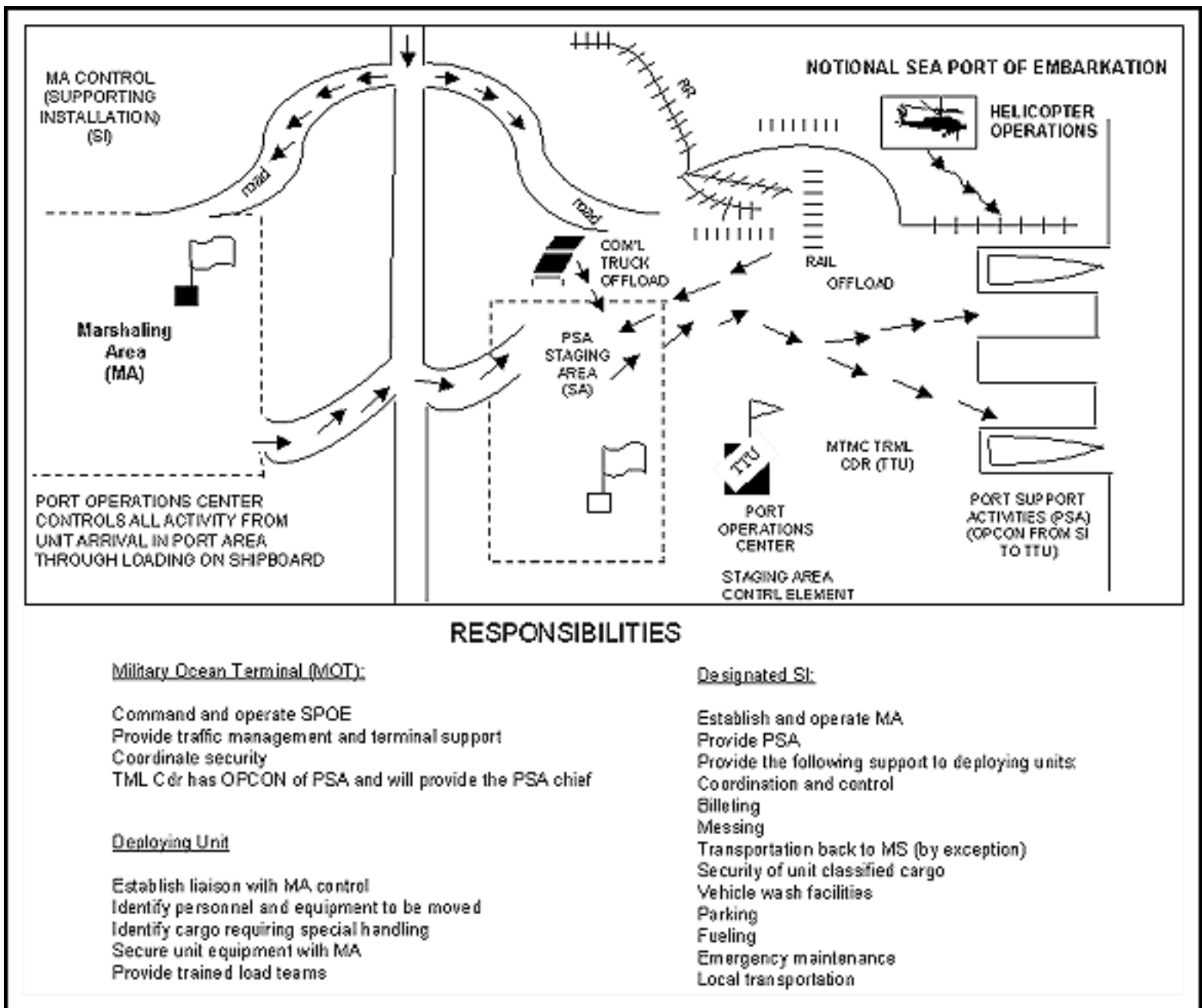

Figure 7-2. Notional SPOE

MOVEMENT BY SEA

In many cases, there is not enough room at the ocean terminal to stage the entire unit or large number of units scheduled to move at the same time. If required, a marshaling area will be operated by a designated FORSCOM supporting installation in close proximity to the port, if possible. At the Marshaling Area, units make final Preparation for Overseas Movement (POM), and are called forward to the terminal as ships are positioned by loading. Supercargoes accompany the unit's cargo on the ship as it sails to the designated Sea Port of Debarkation (SPOD). These personnel periodically start the vehicles and perform minor maintenance to ensure vehicles are ready upon arrival in the theater.

MARSHALING AREA OPERATIONS CONVOYS

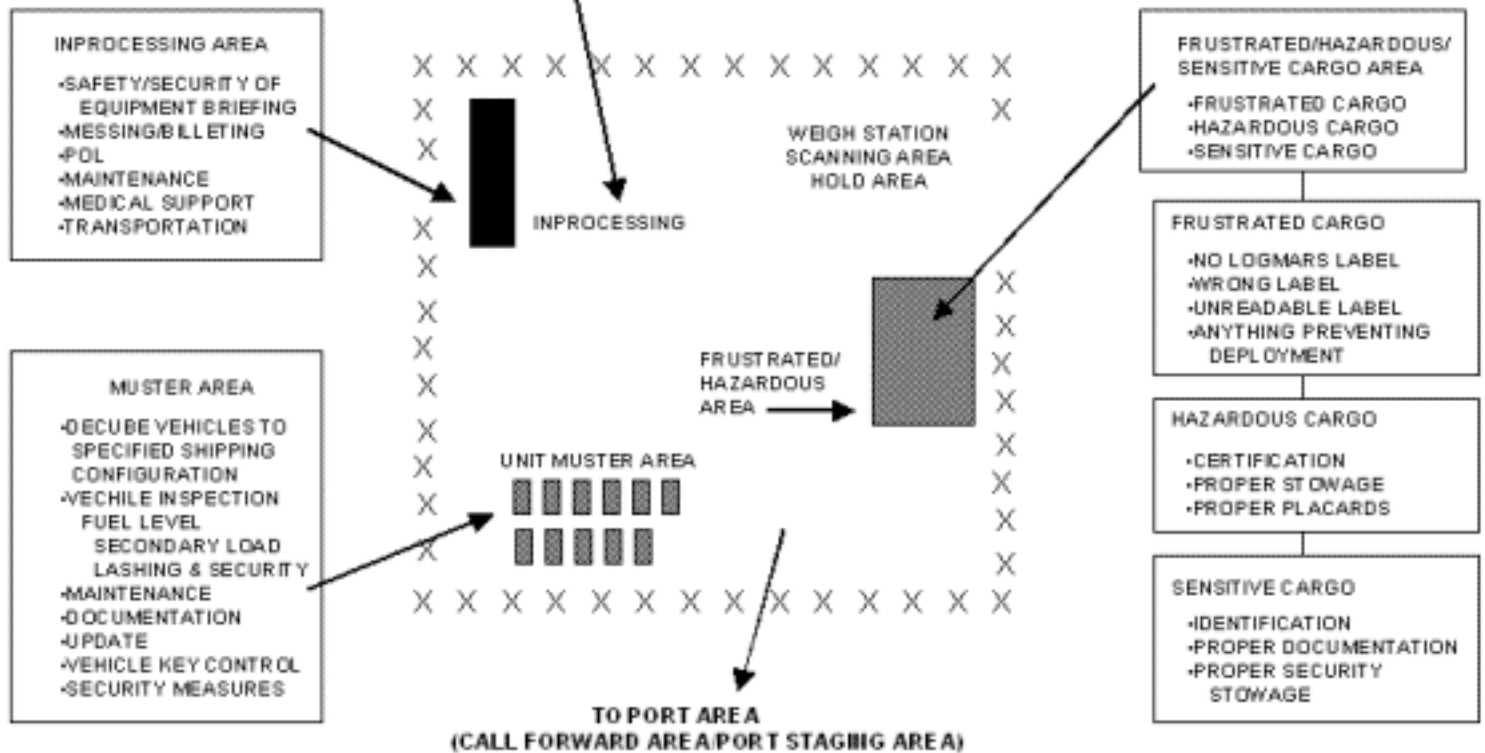

Figure 7-3. Movement by Sea (Marshaling Area)

SECTION II - Aerial

7-34. Departure airfield operations (see [Figure 7-4](#)) are outlined in four separate areas of activity for the unit, DACG (see [Figure 7-5](#)), and TALCE. These areas are the marshaling area, the alert holding area, the call forward area, and the loading ramp area. The TALCE coordinates the overall airlift operations at the departure airfield (see [FM 55-12](#)).

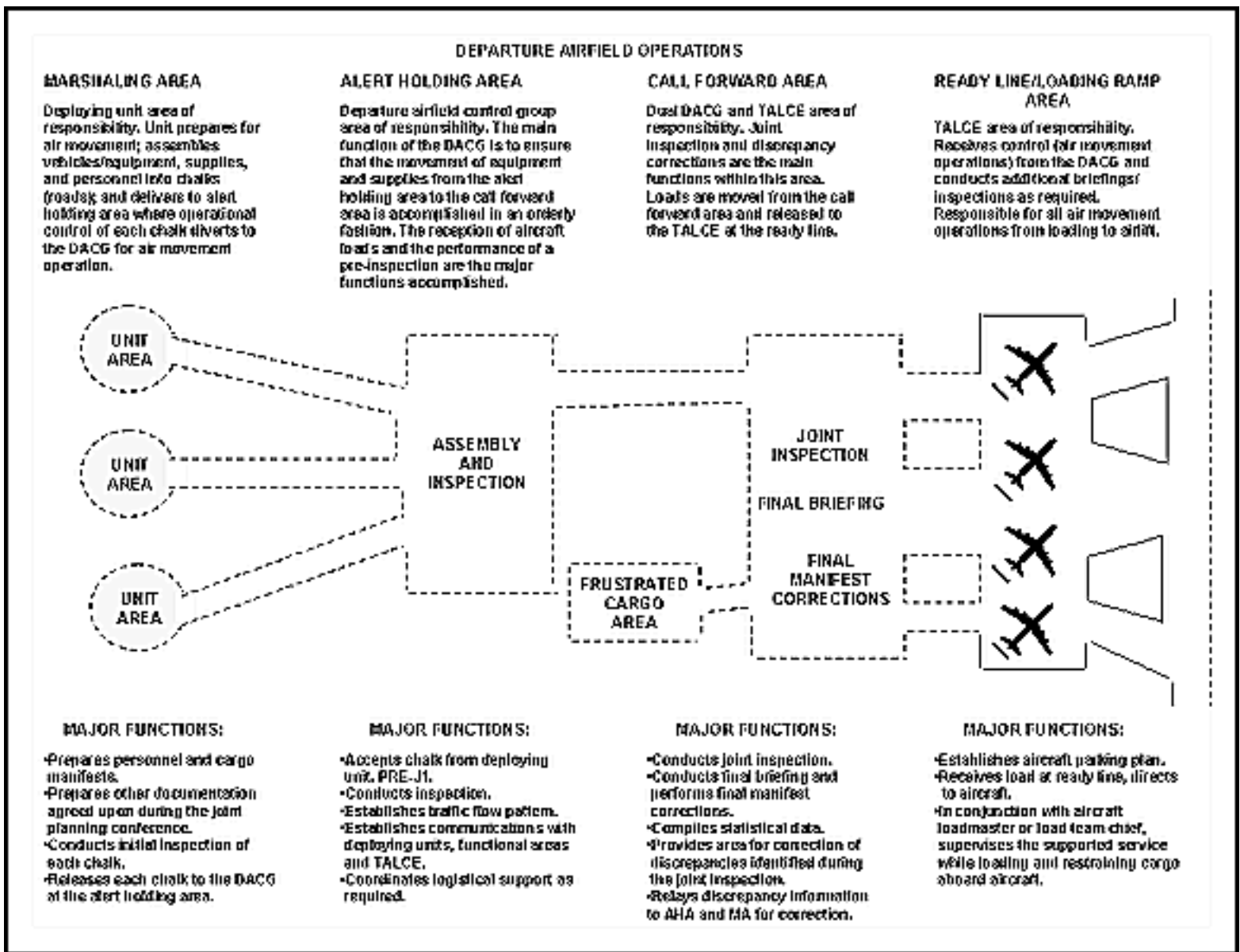

Figure 7-4. Departure Airfield Operations

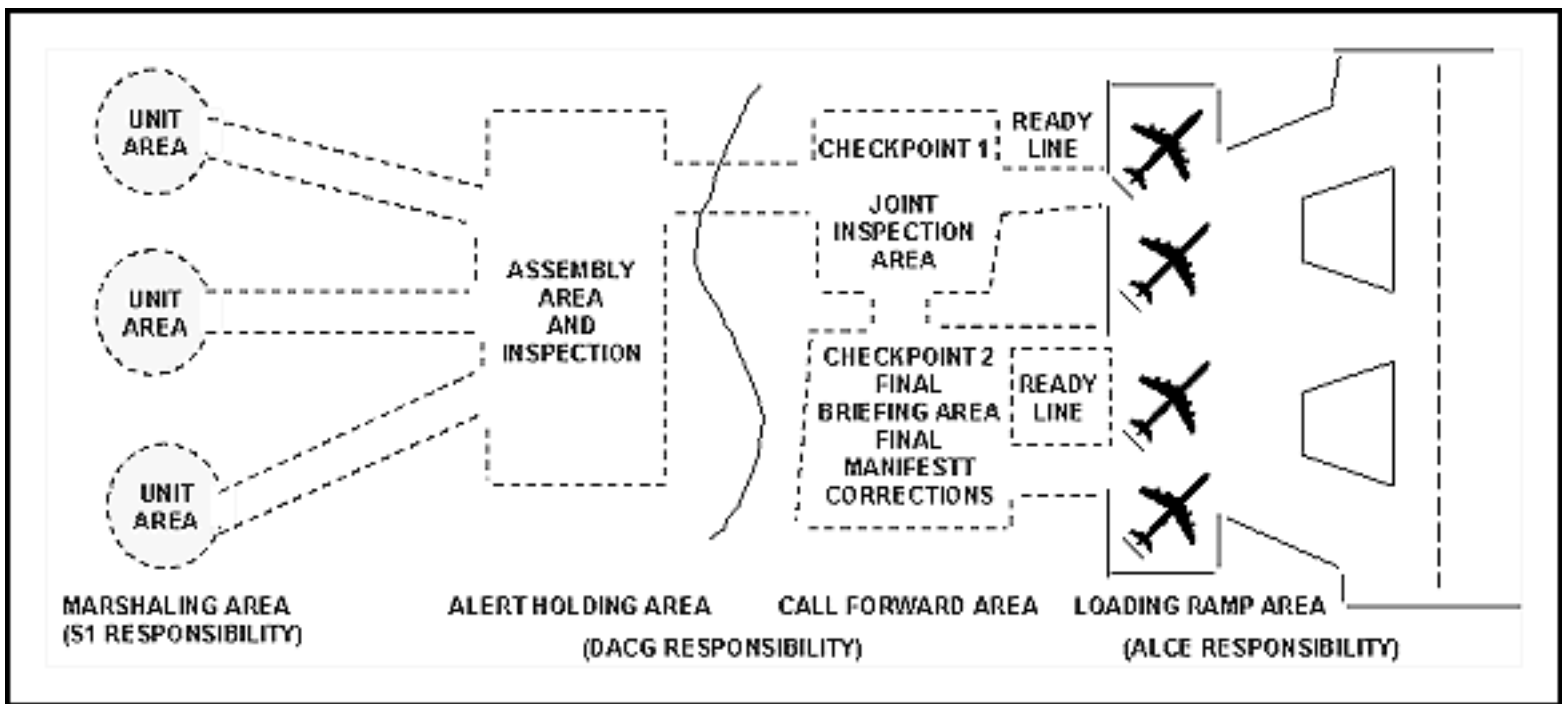

Figure 7-5. D/AACG Functional Structure

MARSHALING AREA ACTIVITIES

7-35. The marshaling area is provided by the installation or base commander of the geographic AOR from which the deploying unit stages its departure. Marshaling area activities are the responsibility of the deploying commander. These activities may take place within the deploying unit's permanent area or in another area to ease movement and control. In either case, the marshaling area activities should take place as close as possible to the departure airfield. Its location should not cause unnecessary congestion to airfield operations or undue hardship to the deploying unit. It may be the area where units may start, continue, or complete preparation for strategic loading.

7-36. The installation/base commander (or the parent organization) who provides the marshaling area will assist the deploying forces. The deploying unit should not be required to perform support functions thus permitting concentration on preparation for the deployment.

7-37. The HS installation or parent organization is responsible for the movement of its subordinate units. The deploying unit should do the following:

- Establish liaison with the DACG and other activities.
- Coordinate a joint planning conference.
- Perform final preparation of vehicles and equipment according to air transport guidelines (to include weighing and marking center of balance).
- Ensure that adequate shoring material is on hand and readily available.
- Prepare personnel and cargo manifests.
- Assemble personnel, supplies, and equipment into aircraft loads according to established load plans.

- Ensure planeload or troop commanders are appointed and properly briefed on their responsibilities.
- Develop alternate (bump) plan for chawks in the event aircraft becomes nonmission capable.
- Pass control of unit aircraft loads to the DACG at the alert holding area.

The DACG is responsible for the following:

- Maintaining liaison with the deploying unit.
- Arranging with the TALCE for Air Force technical assistance required by the deploying unit.
- Establishing communications.
- Maintaining liaison with the aerial port section of the TALCE.
- Calling aircraft loads forward from the marshaling area and assuming control in the alert holding area.

ALERT HOLDING AREA

7-38. The alert holding area is the equipment, vehicle, and passenger control area. It is normally located in the vicinity of the departure airfield. It is used to assemble, inspect, hold, and service aircraft loads. Control of the load is transferred from the individual unit to the DACG at this point. The deploying unit is responsible for the following:

- Ensuring that the aircraft load arrives at the alert holding area at the time specified by the DACG.
- Providing the DACG with passenger and/or cargo manifests and required documentation.
- Correcting load discrepancies identified during preinspection.
- Ensuring vehicle drivers remain with the vehicles until released.

The DACG is responsible for the following:

- Ensuring loads arrive at the alert holding area at the time agreed upon by the deploying unit and TALCE.
- Receiving, inventorying, and controlling aircraft loads as they arrive at the alert holding area.
- Inspecting aircraft loads to ensure that they are complete and correctly prepared. Ensure required shoring, floor protection materials, and 463L dunnage are available.
- Verifying accuracy of weight and balance markings.
- Establishing a discrepancy correction area.
- Inspecting documentation for accuracy and completeness.
- Providing emergency maintenance, POL, and related services, as needed, to accomplish the outloading mission.

- Directing or guiding aircraft loads to the joint inspection area (call forward area).

The TALCE will assist the DACG as required.

CALL FORWARD AREA

7-39. The call forward area is that portion of the departure airfield where the joint inspection is conducted. A final briefing is provided to deploying troops and all manifests reviewed for accuracy. The deploying unit will correct all discrepancies found by the DACG/TALCE joint inspection. The DACG is responsible for the following:

- Establishing communications with TALCE and deploying units.
- Assisting in the joint inspection of aircraft loads and manifests.
- Ensuring that passenger/cargo manifests are correct.
- After loads have passed inspection, moving equipment forward to the ready line and segregate by load.
- In the event of aircraft aborts or discrepancies in the planned ACL, reassembling aircraft loads with the assistance of the TALCE and preparing required manifest changes.
- Ensuring that discrepancies found during the joint inspection are corrected.
- Maintaining statistical data to account for the current status of all unit personnel and equipment scheduled for air movement.
- Ensuring the deploying unit adheres to the established movement timetable.
- Providing loading team personnel and support equipment to include one pusher vehicle per load team.
- Providing gloves, goggles, ear protection, and reflective devices for load team members.
- Escorting aircraft loads to the ready line and ensuring that all personnel are briefed. (Personnel will be briefed on flight line safety, including driving procedures, smoking rules, and other applicable local safety requirements.)
- Retaining a final corrected copy of each passenger/cargo manifest and inspection record.
- Ensuring that deficiencies noted during the joint inspection are relayed to the alert holding area and the unit. This action will prevent recurrence of the same deficiencies. The DACG provides emergency services as required and agreed upon at the joint planning conference to ensure uninterrupted operations.
- Providing fueling and defueling capability and emergency maintenance for vehicles to be transported.
- Providing passenger holding areas as required.

The TALCE is responsible for the following:

- Coordinating with the DACG on all changes required to the aircraft configuration.
- Together with the DACG, conducting the joint inspection using [DD Form 2133](#).
- Providing passenger briefing guide for the passengers' representative to brief the troops for on/off load procedures. Briefing vehicle drivers and passengers on flight line safety, driving procedures, smoking rules, and special precautions.
- Providing a team chief for each loading team.
- Providing passenger escort to the aircraft.
- Notifying the DACG when loads are to be dispatched to the loading ramp area ready line.
- Accepting loads at the ready line and load aboard the aircraft. (If a TALCE is not available, the aircraft loadmaster will accept the load.)
- Providing airflow information to the D/AACG.

LOADING RAMP AREA

7-40. The loading ramp area, including ready line area, is controlled by the TALCE. The planeload commander or troop commander is responsible for the following:

- Following directions of load team chief or passenger escort.
- Monitoring and controlling aircraft passengers.
- Retaining one copy of the final passenger/cargo manifest.
- Providing assistance in loading and securing the aircraft load as requested by the load team chief.
- Ensuring that vehicle drivers and equipment operators follow the instructions of the load team chief or primary loadmaster while loading equipment on the aircraft.

The DACG is responsible for the following:

- Transferring control of the aircraft load to the TALCE at the ready line and monitoring the loading.
- Providing load teams to assist in loading and securing aircraft load as required by the load team chief.
- Maintaining coordination with the deploying unit representative and TALCE.
- Obtaining individual aircraft load completion time from TALCE.

The TALCE is responsible for the following:

- Accepting planeloads from the DACG at the ready line.
- Ensuring that all drivers have been briefed on flight line safety.
- Ensuring that each aircraft load is positioned at the proper aircraft at the

specified time.

- Maintaining liaison with the aircraft crew and the DACG.
- Coordinating with the aircraft primary loadmaster and ensuring that loads are placed aboard the aircraft in time to meet the scheduled departure time.
- Providing (if required) and operating MHE and special loading equipment according to AR 59-105/AFR 76-7/OPNAVINST 4630.13D/MCO 4660.2 and agreements established during the joint planning conference.
- Maintaining communications with the DACG and deploying units.
- Providing aircraft primary loadmaster with required copies of the passenger/cargo manifests and retaining a copy for TALCE files.
- Briefing aircrews, as required.

The load team chief is responsible for the following:

- Receiving loads at the ready line.
- Directing and supervising the loading teams and vehicle drivers.
- Coordinating with the aircraft primary loadmaster, directing all loading operations, and ensuring all equipment and supplies are properly restrained in the aircraft.
- Coordinating with the TALCE ready line coordinator for any special assistance or equipment needed.
- Collecting required copies of the passenger/cargo manifest and making sure that they are given to the aircraft primary loadmaster.
- Passing load completion time to the AOC section of the TALCE.



[RDL](#) [Table of](#) [Document](#) [Download](#)

[Homepage](#) [Contents](#) [Information](#) [Instructions](#)

Chapter 8

Reception and Onward Movement

This chapter provides an overview of the last two phases (reception and onward movement) of the deployment process (see [Figure 8-1](#)). Reception and onward movement are the responsibility of the theater commander implemented by TAMCA, TRANSCOM, or equivalent organization. Arrival within the theater marks the transition from the strategic to operational level. Transfer of advance arrival information from USTRANSCOM to the gaining commander is essential to plan for reception and onward movement of theater resources.

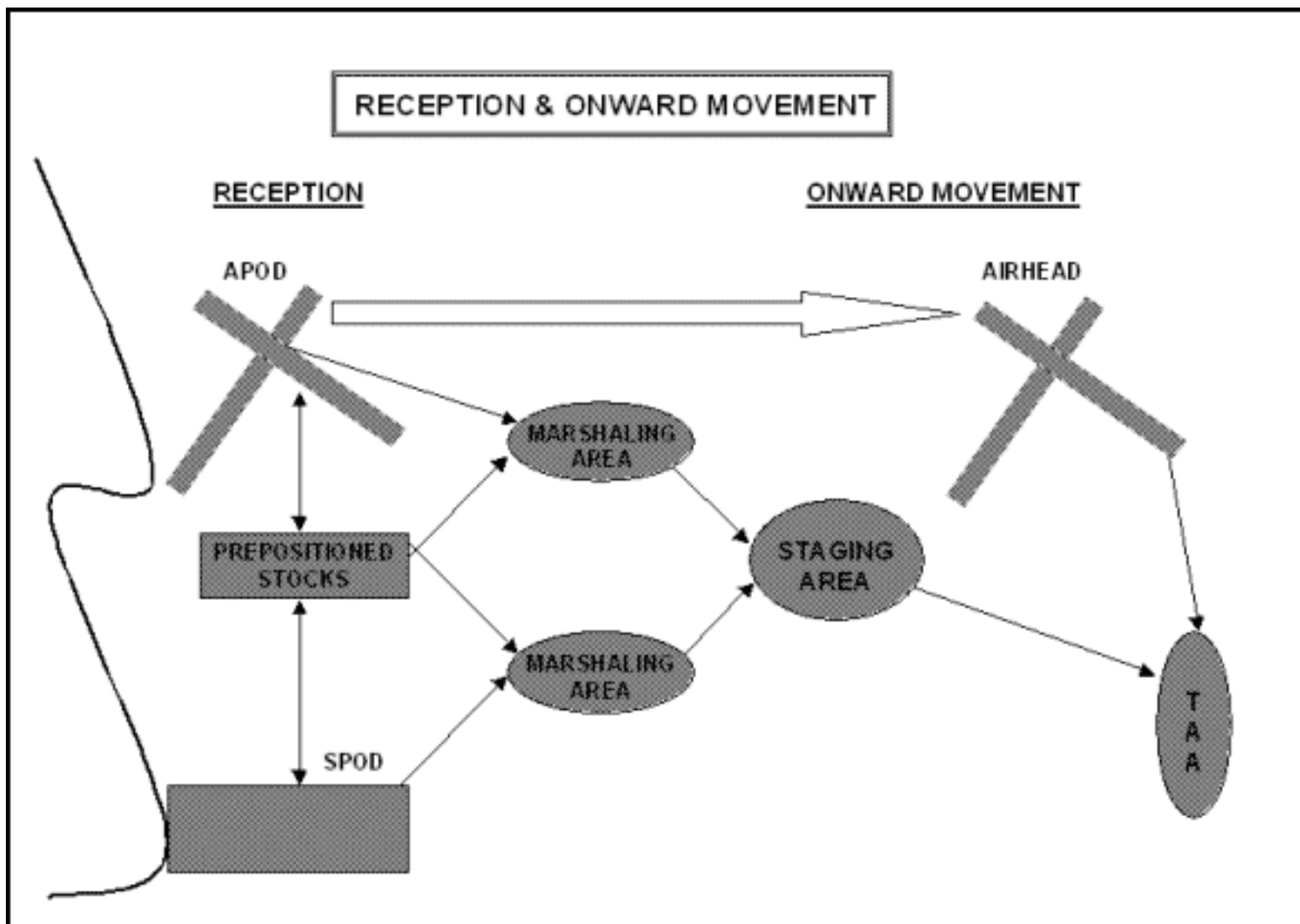

Figure 8-1. Reception Process

RECEPTION AND ONWARD MOVEMENT PROCESSES

8-1. There are two different reception and onward movement processes. One is for units deploying with their own equipment and another for units deploying only with TAT equipment. This second reception and onward movement process is defined by plans that require the unit to draw AR stocks.

8-2. Reception is a command responsibility. The TAACOM is responsible for the health, welfare, and life support of arriving forces and for assisting with their onward movement. Onward movement is coordinated by movement control units to ensure a smooth flow of personnel, equipment, and supplies through the PODs and inland LOCs.

8-3. Unit personnel should arrive at the APOD to coincide with equipment draw, either at the SPOD or at AR stock sites. When unit personnel arrive, they may move as follows:

- Directly to a unit marshaling area if the unit moves with its equipment.
- To AR stock sites to draw equipment.
- To waiting aircraft for theater air movement (AAI).
- Directly to the SPOD to receive unit equipment off-loaded from vessels at the SPOD.
- To holding areas, if equipment is delayed.

8-4. Planning must focus on moving units through the PODs without delay. Marshaling areas are planned to allow rapid clearing of the PODs and make staging areas available for off-loading. This reduces port congestion, thus reducing the potential for work slowdowns or stoppages in discharge operations.

8-5. Theater based reception begins with the arrival of forces and their sustainment at the POD. The primary challenge of this process is port clearance. Except in the case of forcible entry, port opening forces should precede the arrival of combat forces. Other CS and CSS forces may either precede or arrive concurrently with combat forces to conduct force reception and onward movement operations, establish theater distribution infrastructure, or to conduct security operations.

RECEPTION AT THE APOD

8-6. Reception at the APOD is coordinated by the senior logistics commander and executed by an ATMCT, AACG, or both, depending upon the magnitude of the operation. The ATMCT and/or AACG must be in the lead elements of the transported force. Augmentation with cargo transfer units or HNS is desired to rapidly clear the port.

ARRIVAL AIRFIELD OPERATIONS

8-7. The main areas of the arrival airfield are the off-load ramp, the holding area, and the unit marshaling area (see [Figure 8-2](#)). The TALCE will supervise off-loading arriving aircraft. The AACG will escort loads to the holding area and assist the unit in assembling and moving to the marshaling area.

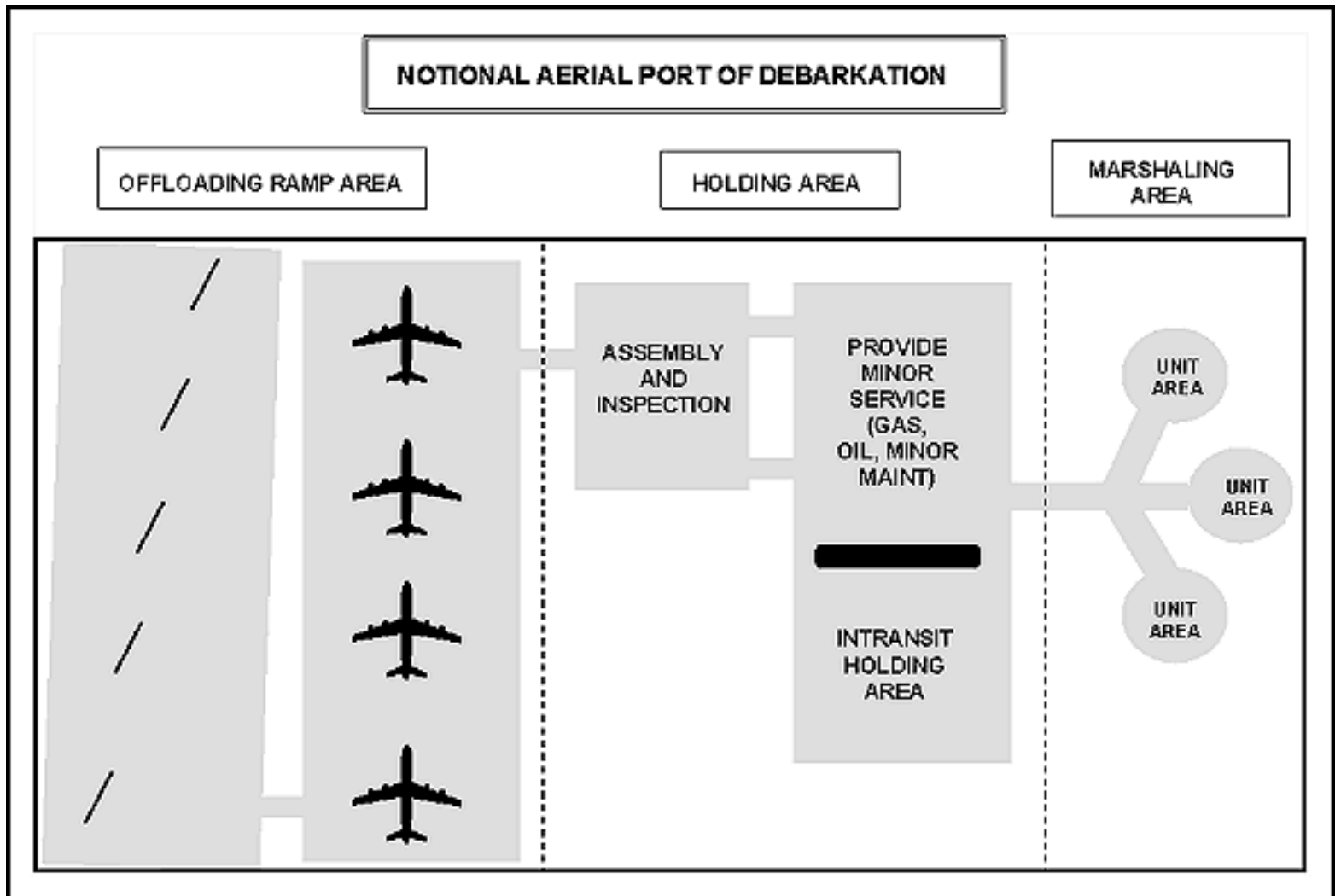

Figure 8-2. Notional Aerial Port of Debarkation

OFF-LOAD RAMP AREA ACTIVITIES

8-8. The off-load ramp area activities are controlled by the TALCE. Each load will be released to the AACG for return to unit control at the holding area. The chalk leader or troop commander will perform the following:

- Provide assistance to the loadmaster.
- Comply with instructions from the off-load team chief when unlash and off-loading from the aircraft.
- Ensure that all aircraft tie-down equipment is returned to the TALCE.
- Retain all shoring and dunnage for redeployment.
- Provide one copy of the passenger and cargo manifests to the AACG.

The AACG will perform the following:

- Maintain coordination with the deploying unit and TALCE representative.
- Provide off-load teams and support equipment as required.
- Accept each planeload from the TALCE at the established RP.
- Remove shoring and dunnage from the aircraft and transfer it to the unit.

The TALCE will perform the following:

- Advise the AACG of the airflow and expected arrival of aircraft.
- Plan and supervise aircraft parking.
- Receive passenger and cargo manifests from the aircraft loadmaster.
- Supervise off-loading the aircraft, including removal of shoring and dunnage.
- Provide all MHE and special off-loading equipment including operators, as required, in accordance with AR 59-105/AFR 76-7 and agreements established during joint planning conferences.
- Provide ITV by reporting arrival of loads and release to the AACG.

HOLDING AREA ACTIVITIES

8-9. The deploying units are responsible for providing unit liaison personnel to AACG and for assisting the AACG as required. The AACG will perform the following:

- Coordinate with the TALCE and the deploying unit.
- Provide support to arriving units as determined during the joint planning conference.
- Maintain ITV of arriving loads.
- Release aircraft load to the deploying unit commander or his representative at a predesignated location.
- Coordinate MHE and transport of the movement of aircraft pallets to the unit marshaling area for pallet breakdown.
- Provide fuel, oil, and minor maintenance for transported vehicles.
- Provide emergency services to accomplish the mission.

NOTE: Units may proceed to an AAI. Soldiers and TAT equipment are transloaded from strategic airlift to tactical airlift at the APOD site. Movement procedures are generally the same as in [Chapter 7](#). Refer to [FM 55-10](#).

UNIT MARSHALING AREA

8-10. The deploying unit terminates the air movement at its marshaling area. Equipment is reconfigured for onward movement. Units will perform the following:

- Install equipment previously removed for strategic transport.
- Ensure that all aircraft pallets and nets are returned to the TALCE or AACG.
- Perform required maintenance checks, including refueling.

- Prepare and organize for movement (convoy, rail, airlift, and inland water).

RECEPTION AT THE SPOD

8-11. When vessels arrive at the SPOD, the port commander is responsible for discharging the unit equipment, staging the equipment, maintaining control and ITV, and releasing it to the unit. Units receive this equipment and move it to a marshaling area outside of the terminal. The length of time needed to discharge a vessel depends on the type of vessel and throughput capacity of the port, influenced by availability of berths, equipment, and stevedores. [Figure 8-3](#), shows a notional SPOD.

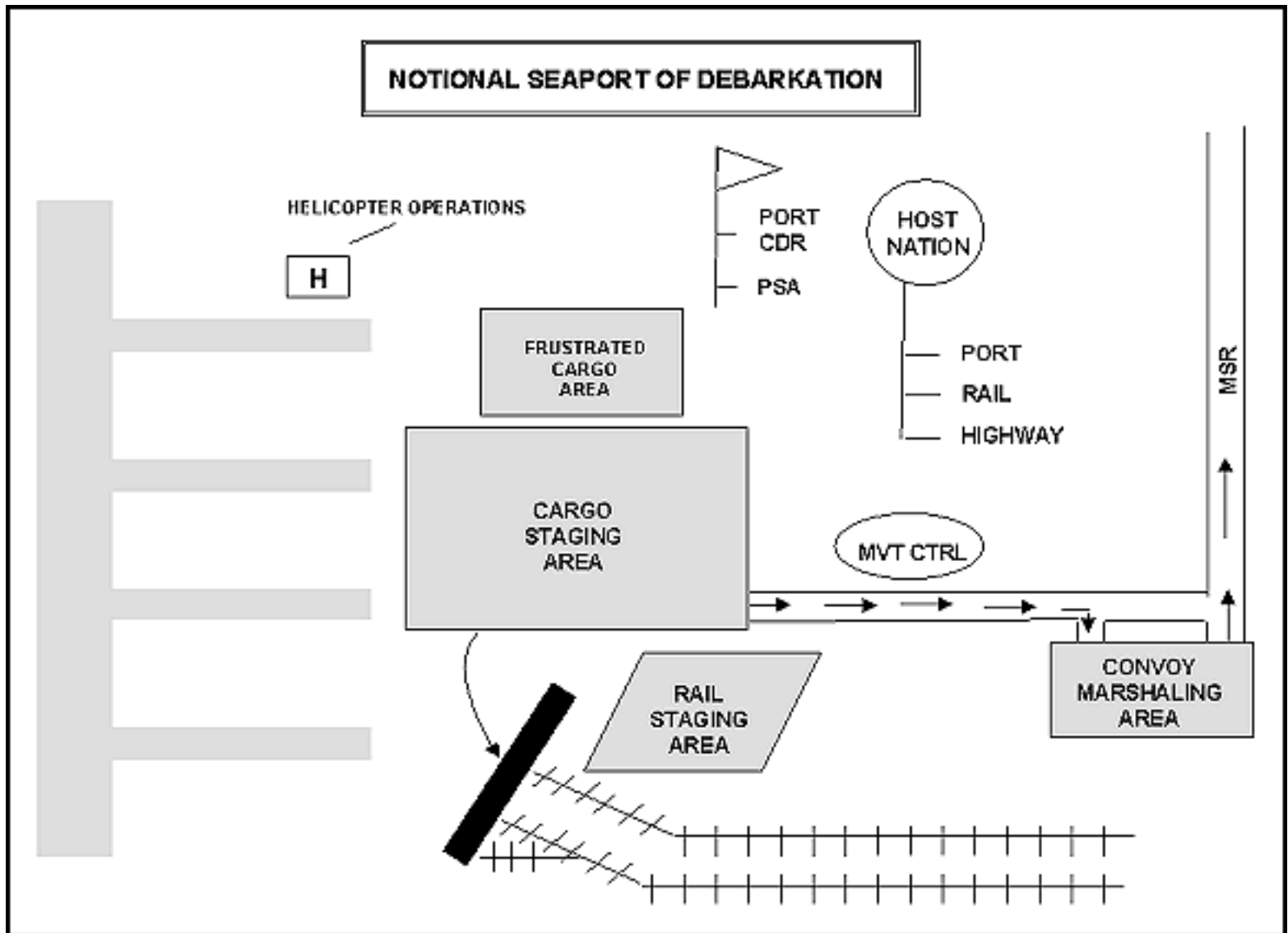

Figure 8-3. Notional Seaport of Embarkation

SPOD OPERATIONS

8-12. The SPOD will be commanded or contracted by MTMC (TTBde) or operated by the transportation group until MTMC can negotiate HN/commercial contracts. All SPODs must have assured communications and the capability to provide ITV of unit equipment during this phase of movement. The port operator will perform the

following:

- Prepare and update port operations plans.
- Establish and direct port communications, safety policies, and physical security procedures.
- Establish and maintain liaison with the USTRANSCOM representatives, port authorities, movement control organizations such as a JMC, and the logistics command.
- Contract for interpreters.
- Direct PSA operations.
- Provide harbormaster functions, such as assigning anchorages and berths to arriving vessels.
- Supervise vessel discharge.
- Coordinate all cargo activity and discharge plans with the vessel master or his representative.
- Receive, discharge, and transship cargo according to supported command directives.
- Regulate military traffic within the port.
- Task units, whether assigned, attached, or contracted, to accomplish port operations.
- Execute port security plans in coordination with Coast Guard.
- Compile cargo receipt and processing data in automated systems for documentation, management information, and ITV.
- Perform liaison with arriving units.
- Analyze terminal work load capabilities and quantify missions that may be performed by contract, HN, or military stevedore support.

TRANSPORTATION COMMAND (COMPOSITE)

8-13. The transportation command is an operational level Army unit that provides theater wide transportation services. When deployed, it has a major responsibility to open and operate seaports during contingency operations. It conducts ocean terminal operations at established and austere ports and where no port facilities exist. It is assigned to the ASCC.

8-14. The transportation command consists of soldiers, systems, and equipment required to operate a port. It employs Army standard management information systems such as ICODES, WPS, and LOGMARS. The transportation commands that perform terminal service missions includes the following:

Group Level

8-15. HHC transportation group (composite) may command two to six transportation battalions primarily performing fixed port and LOTS operations. With a contracts

supervision detachment assigned, the group may perform a role similar to the TTBde in that the group may administer contract and HN terminal service operations support.

Battalion Level

8-16. Terminal service battalions and companies, crane and automated cargo accounting detachments, and various lighterage companies load and discharge cargo at either fixed ports (discharge two to four vessels at the same time) or LOTS operations (discharge two vessels at the same time) without the need for external stevedoring assistance.

Company Level

8-17. Terminal service and cargo transfer companies are the basic working units in theater terminal operations. They load and discharge vessels.

STAGING AREA OPERATIONS

8-18. As the vessel readies for off-loading, the port commander establishes a staging area for the transshipment and accounting of equipment. He determines discharge priorities based on the supported CINC's guidance. He also assigns missions to terminal service units with support from the PSA who discharge vessels according to the port commander's priorities. He assumes custody of the cargo from the vessel master upon discharge. Equipment is then staged based on theater onward movement requirements. As unit personnel arrive in the theater, they are transported to the SPOD to assume custody of their equipment. Equipment is assembled and moved into the marshaling area.

MARSHALING AREA OPERATIONS

8-19. The marshaling area is an area where units reconfigure their equipment and prepare for onward movement. It is located next to the port. Prompt clearance of cargo from the terminal is essential to the efficiency and success of the total theater logistics system. It is also necessary to avoid serious congestion in the terminal staging area. Marshaling areas should provide for the following activities and functions:

- A central control and inspection point.
- Security area for sensitive items.
- Life support facilities.
- A traffic circulation plan showing movement flow into the marshaling area and from the staging area.
- Maintenance and fuel area for vehicles and equipment.
- Unpacking containers and repacking cargo as secondary loads.
- Consolidating movement requirements and submitting movement requests.

- Emergency supplies and equipment for isolating and disposing of HAZMAT spills.

Since marshaling areas are not always available, units should be prepared to move directly into their AOs from the port staging area. When this is necessary, the marshaling area functions will have to be performed in the port staging area. This requires additional coordination with the port commander so that these activities do not interfere with discharge operations.

ONWARD MOVEMENT

8-20. Transportation request procedures are required for the orderly and expeditious movement of unit equipment and supplies. The following criteria may be used to assist in the selection of modal transportation:

- **Service considerations.** Provide service according to need. The theater commander's priorities and the nature of the shipment determine the need.
- **Security considerations.** The type of security required for the shipment depends on the type of cargo being shipped, such as nuclear shipments, hazardous or classified cargo, or Class V shipments.
- **Political considerations.** In some theaters, particularly in OOTW, some types of cargo may be of a sensitive nature to the local population. In these cases, cargo may have to stay covered at all times, be moved under the cover of darkness, or be moved by air.
- **Tactical considerations.** A tactical environment will present special challenges to the MCT. Not only will it have to react to transportation assets being attacked en route, but the destination may have changed. A tactical environment may include the following:
 - **Weapons of mass destruction.** The threat of these weapons will be ever present. Rerouting or transloading of cargo and other protective measures are considerations for mode selection.
 - **Rear area threat.** CSS units are expected to defend themselves against any threat while continuing their mission.
 - **Highways.** Highways and bridges should be intact, passable, and able to handle the load's weight and height. Using MSRs may require convoy and/or highway clearances before committing assets.
 - **Rail.** Lines should be intact and off-load facilities available. Using rail assets may constitute a multimode shipment. This could mean highway assets are needed to ship the cargo from the shipper to the rail loading site and from the rail discharge point to the receiver.
 - **Air.** Airfields should be operational and required aircraft available. If Army air (helicopters or fixed-wing) is the selected mode, the origin MCT must obtain movement clearance before forwarding requests to the TAMCA or corps MCC for validation and mode operator tasking. If Air Force air is the selected mode, a preplanned airlift request is forwarded

to the TAMCA/MCC for validation and processing. If scheduled flights have been established, the origin MCT goes directly to the ATMCT to book the cargo.

THEATER MOVEMENT PLANNING

8-21. A comprehensive plan for reception at the POD and onward movement requires adherence to a step-by-step process. Initial planning should include estimating the placement of movement control elements, mode operating units, mode change units, any specialized handling requirements, and any anticipated HN assistance. During this process, the supported CINC's staff will perform the following:

- Obtain requirements data from operational planners. This data is normally found in the TPFDL and the base plan. More information can be obtained from PERSCOM, DCSLOG, TAMMC, and J3.
- Assess the requirements data. Ensure that all needed information is available, such as RDD, priority, equipment characteristics, and special requirements.
- Group the data by destination area.
- Sequence the requirements for RDD.
- Examine each requirement for the first day. Look at the type requirement, equipment characteristics, modes servicing the destination, and any data that would affect mode selection.
- Make mode selection for each phase of movement.
- Select POD and onward movement sequence from POD to destination.
- Estimate processing, assembly, and preparation for onward movement time at POD. Determine required date and time of arrival at POD.
- Examine the onward movement sequence for all modes used and look for conflicts. Fix conflicts by either rerouting, changing modes, or rescheduling. Reconfirm that the selected route can accommodate any oversize or overweight cargo or equipment being moved.
- Go over all special handling requirements at the POD, each transportation mode, and destination. Ensure that enough equipment is available to meet the needs at the points and times required. If not, reschedule or reroute as needed. If any changes are made, reexamine for route conflicts.
- Examine the time phased work load at the POD and destination. Determine if the work load can reasonably be accomplished. If not, decide if the problem should be fixed by changing POD, rescheduling, or adding equipment and manpower.
- Identify en route support requirements for fuel, mess, maintenance, and billeting. Make arrangements as needed. The TAACOM is tasked to provide this support through its regionally organized ASG.
- Determine critical points where movement control or traffic control personnel should be positioned to keep the flow moving smoothly. Arrange for personnel to be posted with required communications assets.

- Remember to consider equipment, such as railcars and trucks, returning from the corps areas for new missions when looking for routing/sequencing conflicts.
- Establish collection points near the controlled routes where refugees could be expected. Have traffic control personnel or MPs remove refugees from controlled routes and take them to collection points.

UNIT MOVEMENT PLANNING

8-22. When the mission dictates, large unit movements must be executed quickly. Synchronization of movements is critical because as units begin massing, they are most vulnerable. The requirements to maintain uninterrupted transportation to supported units in conjunction with a tactical move requires continuous coordination. The senior movement control organization, such as the TAMCA, will be the primary coordinator for the movement. The TAMCA may assign the mission of the traffic management function to one of its subordinate movement control elements. The corps MCC, DTO, and TAMCA will control routes in their respective areas. Using routes outside each agency's area of influence must be coordinated with the owning organization. The unit must obtain the following information early in the planning process:

- The priorities for movement as established by the J3/G3 and the required arrival times.
- The current location of the moving forces.
- The assembly areas at destination.
- The marshaling areas, if any.
- Special en route supply requirements.
- The order of march by type and density of the force.
- The military load classification of each route (to find a route that will accommodate the load).
- The time of movement (day or night).
- Transportation support requirements.

Calculations can be made in advance for each type of unit. For instance, the road space, time gaps, and so on, can be precalculated.

8-23. Upon notification of a planned move, the TAMCA starts with the origin, destination, and the time available for move and then examines the road network available to support the move. After determining how many routes are available, routes are allocated according to the equipment moved, priorities, and time requirements. Unit movement schedules are then prepared by units and submitted to movement control elements. The HN may control MSR access through the civil and MP organizations. If so, the TAMCA obtains clearance for use of the selected routes from the HN territorial authorities before distributing the movement schedules. After preparing the movement schedules, the TAMCA examines routes and road movement

tables and determines the critical points where traffic control must be established. Air defense and fire support are arranged as soon as the routes and times are determined.

8-24. Requests for additional transportation support are submitted to supporting MCTs. The MCT commits transportation assets. Units tasked then provide the support directly with the moving units.

8-25. Priorities may change because of the tactical situation. All transportation movement information is compiled in an annex of the OPLAN. Refer to [FM 55-10](#) for further information on movement planning and control.

[RDL](#)[Table of](#)[Document](#)[Download](#)[Homepage](#) [Contents](#) [Information](#) [Instructions](#)

Chapter 9

Redeployment

Redeployment is the preparation for and movement of forces, manpower, and materiel from an AO to follow-on designated CONUS/OCONUS locations. The physical act of moving includes theater and strategic movement. This chapter focuses on redeploying a force from an OCONUS base of operation to a CONUS HS. Theater commands may tailor this redeployment process to meet unique requirements.

The objective of a redeployment is to maintain unit integrity of equipment, supplies, and personnel. Redeployment should not be considered as retrograde movement, but as a new deployment. Units may conduct successive deployments into other crisis scenarios.

REDEPLOYMENT RESPONSIBILITIES

9-1. TA (general staff level personnel) transportation personnel monitor transportation functions. Their primary duties are as follows:

- Advise the commanders and staff on all transportation matters and provide technical guidance to the TAMCA.
- Act as the transportation staff link between TA and the JMC. The JMC is established to coordinate the employment of all means of transportation to support the concept of operations. The JMC recommends allocation of all transportation resources available to the theater according to the commander's established priorities.

9-2. The TAMCA is a subordinate organization to the TA. It is a primary source of information for the TA commander to plan and control the operations of the Army transportation system. The TAMCA makes movement management immediately responsive to the theater commander's desires. The following is a list of TAMCA's responsibilities that relate to redeployment. The chief responsibilities of TAMCA include the following:

- Coordinating with movements with supporting commands and all corps within a theater.
- Providing and coordinating movement management services and highway traffic regulation.
- Maintaining container accountability.
- Coordinating movements with allies and the HN.
- Developing the AO movement control policy.

- Submitting redeployment documentation for ITV.
- Preparing theater redeployment order.
- Providing initial AUDEL printouts to the UMO.
- Providing sites for AUDEL data base update.
- Coordinating MHE requirements between deploying units and sources (both commercial and military).
- Assisting UMOs with preparing unit movements documents.
- Coordinating highway and air passenger movements.

Actual movement responsibility falls to several commands, one of the principal commands being the TAMCA. Its contact with field units is through the supporting MCT and at airfields, through the ATMCT. At both ports and airfields, there are transportation command personnel with support equipment activities to help in the redeployment process. The TAMCA is located so that uninterrupted communications with the TA HQ, the TAMMC, transportation battalions (MC), Corps MCC, and the USTRANSCOM are facilitated.

MOVEMENT CONTROL TEAMS

9-3. The MCTs' duties and functions will depend on the immediate situation. These duties may include the following:

- Receiving and coordinating transportation requirements.
- Selecting the mode (air, rail, inland waterway, or highway) for unprogrammed moves.
- Maintaining communication with the transport services, shippers, receivers, and HN transportation resources.
- Keeping a status of and advising the TAMCA or Corps MCC and transportation battalions (MC) on the following:
 - Activities capabilities to ship and receive.
 - Location of units and support activities.
 - Availability of modes of transport.
 - Asset use capacity (the percentage of route capacity and transport capacity being used) and trends.
 - General transportation movements situation in their areas.
- Receiving, processing, and forwarding requests and replies to requests for movement over controlled routes.
- Reporting requirements.
- Scheduling traffic on controlled routes according to the commander's priorities.
- Regulating movements by granting or denying clearances to local activities.

SITE MOVEMENT COORDINATOR

9-4. A site movement coordinator, designated by the command, is the commander's representative who oversees unit movements and associated cargo from the RAA to the POE. The site movement coordinator establishes the TC-ACCIS host facility. He also assists the UMO and TAMCA in determining and reporting movement requirements needed to clear the site. In some cases, the site movement coordinator is also an intermediate command level UMO.

INTERMEDIATE COMMAND LEVEL MOVEMENT OFFICER

9-5. The intermediate command level movement officer coordinates movement planning guidance for subordinate units and unit movement requirements and provides recommendations to enhance overall movement planning and execution. Intermediate command level UMOs include the Bn, Bde S4, DTO, and the CTO.

UNIT MOVEMENT OFFICER

9-6. The UMO should perform the following:

- Prepare and maintain unit movement plans.
- Update and maintain unit movement documentation.
- Coordinate operational and logistical movement requirements.
- Coordinate with the TAMCA representative for external unit movement support of personnel and equipment.
- Prepare and submit redeployment DEL.
- Obtain and distribute military shipment labels.

UNIT LOAD TEAMS

9-7. Unit load teams are responsible for preparing vehicles for shipment. This includes the following:

- Securing classified or protected sensitive equipment.
- Weighing and marking equipment for shipment by air or rail.
- Stenciling appropriate cargo.
- Properly placing military shipment labels.
- Affixing documents.
- Protecting fragile components.

Unit load teams also drive the unit's vehicles and palletized ammunition and other hazardous cargo.

LIAISON TEAMS

9-8. The liaison teams represent the command at POEs. These teams assist in resolving movement challenges and aid in outloading unique equipment. They are knowledgeable on the personnel and cargo transiting the site. The liaison teams

perform the following:

- Correct deficiencies.
- Coordinate logistics and administrative support challenges of redeploying units.
- Assist port or airfield support personnel in directing unit movements.
- Provide documentation for onward movement for ITV.

SUPERCARGOES

9-9. Supercargoes are personnel designated by a deploying unit, on orders, to accompany, secure, and maintain unit cargo onboard a vessel. They provide maintenance and liaison during cargo reception SPOE, vessel load and sea operations, agricultural and customs clearances, and SPOD port operations. See [Appendix G](#) for more information on supercargoes.

CUSTOMS AND AGRICULTURE INSPECTIONS

9-10. The MCI, USCS, or HN customs service will inspect the cargo before loading. The unit must ensure the cargo is ready for inspection and clearance. Before the inspection, the unit should do the following:

- Make an appointment for the inspectors to examine the cargo.
- Thoroughly clean all vehicles and cargo. Remove all loose ammunition and HAZMATs from vehicles.
- Provide customs personnel access to all cargo requiring clearance. Ensure that keys and a packing list are available for inspection.
- Provide any information needed to clear cargo during the customs inspection.
- Keep customs clearance documents in a permanent file.
- Notify customs of classified material being shipped.
- Prepare for customs inspections according to [DOD Regulation 5030.49-R](#) and [FM 55-17](#).

REDEPLOYMENT PROCESS

9-11. In preparing for redeployment, the supported CINC decides how the operation will proceed. These factors may include the following:

- CJCS residual force mission statement.
- CJCS requirements to reconstitute a response capability.
- Political negotiations and other theater needs.
- Occupation/nation building/humanitarian missions.
- Establishment of Army Reserve stocks in AO.
- Security of the force.
- Constraints of RC forces and individuals in theater.

REDEPLOYMENT REQUIREMENTS AND CONSIDERATIONS

9-12. An important aspect of redeployment is the restoration of any environmental violations committed by US Forces. During major federal actions abroad, US Forces will comply with all applicable regulations and standards, including SOFAs, treaties, and international agreements. In addition to any reclamation that may be required, planning considerations must be given for the removal of HAZMAT which was deployed to the host country or created during operations in the host country. Further environmental information can be found in [AR 200-1](#) and [AR 200-2](#).

9-13. Ammunition will be palletized and shipped separately from unit equipment. It will be inspected for serviceability and hazards and recreate before redeployment. All explosive safety standards for peacetime will be met. This is a major project that requires a combined effort by the US Army Materiel Command and redeploying forces.

9-14. Some materiel already on requisition when hostilities cease will not be required in the theater, or some categories of supplies will not be needed in the quantity requested. To the extent possible, units should use theater stocks. If no longer needed, cancel requisitions previously submitted for supplies. Supplies in-transit may be diverted to other destinations throughout the world or to CONUS. Materiel and movement managers need to closely monitor this situation. Material management centers must change the DODAAC ship to addresses for redeploying units.

9-15. Accurate automated documentation is required for redeployment. Properly prepared and accurate DEL entries into TC-ACCIS will enable seaport operators to prepare accurate vessel manifests at the SPOE. Successful shipping operations depend on the accuracy of vessel manifests and delivery of all equipment in order for MTMC to successfully plan the off-load and follow-on transportation requirements at the SPOD.

REDEPLOYMENT PHASES

9-16. The strategic redeployment process has six phases (see [Figure 9-1](#)). The procedure begins after combat reconstitution when the force closes on the TAA to begin the redeployment sequence. The force requests movement authorization into the TAA or RAA through the TAMCA or equivalent level of command.

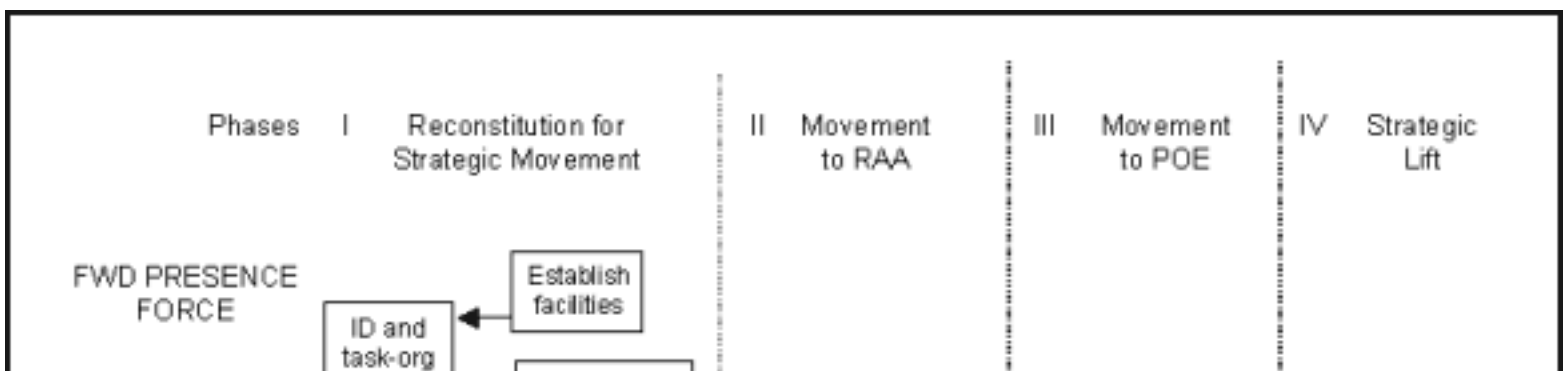

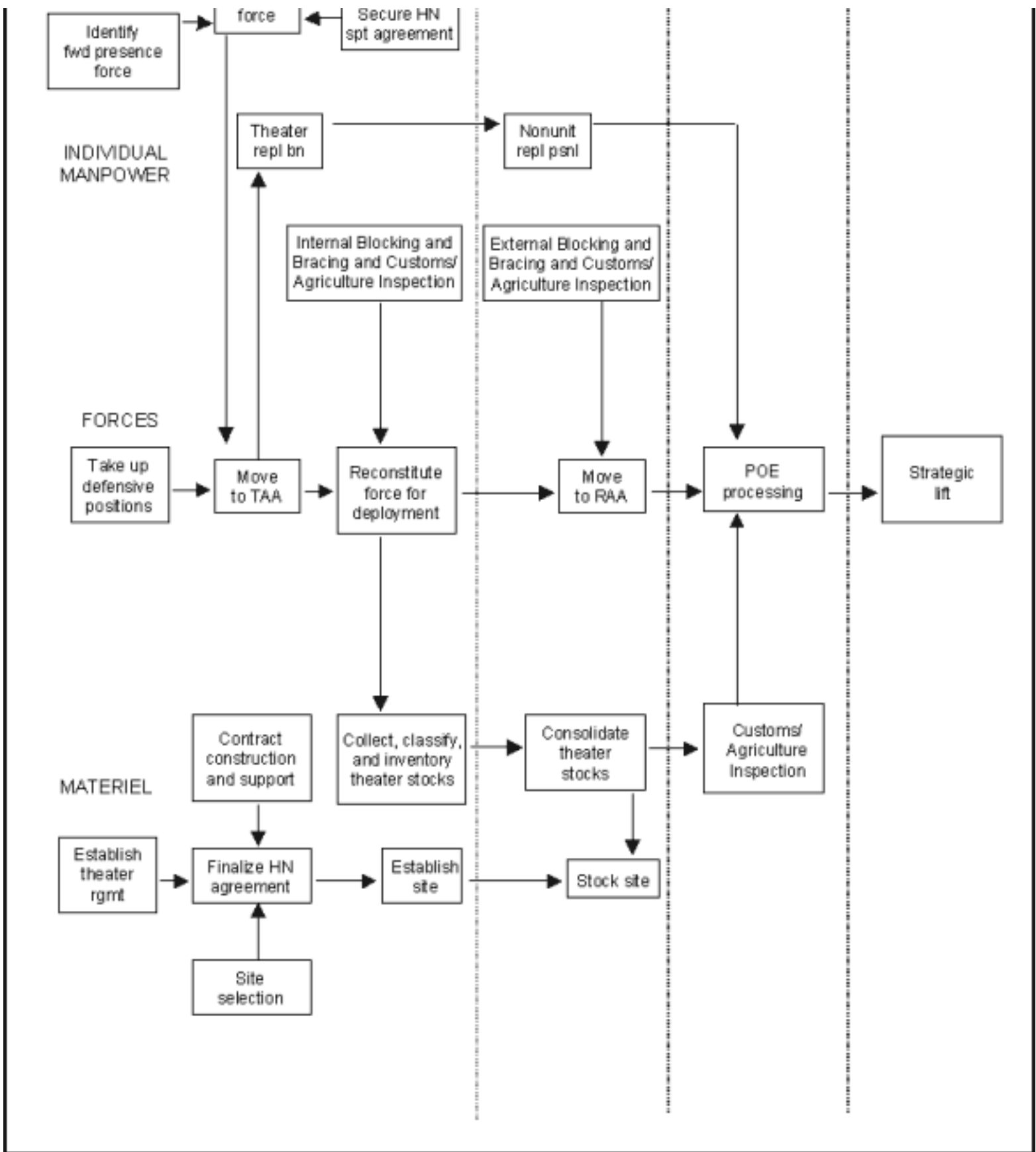

Figure 9-1. Strategic Redeployment Process Phases I through VI

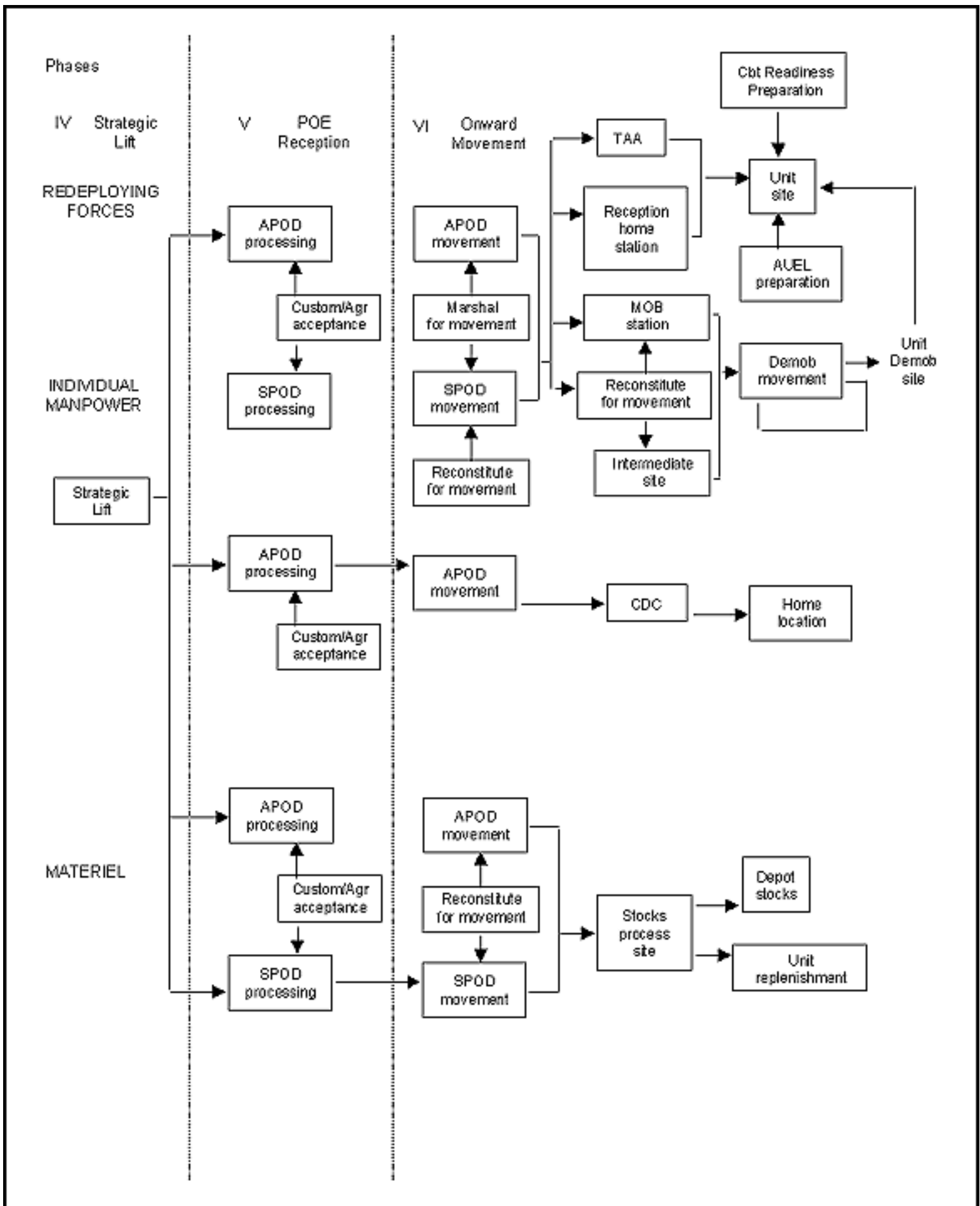

Figure 9-1. Strategic Redeployment Process Phases I through VI (continued)**PHASE I - RECONSTITUTION FOR STRATEGIC MOVEMENT**

9-17. Forces that no longer have a battlefield mission move back to designated TAAs. Commander's actions include the following:

- Reconstituting the unit.
- Identifying excess materiel.
- Coordinating customs inspections.
- Cross-leveling personnel and materiel.
- Consolidating supplies for movement.
- Reconciling UMD.
- Requesting movement instructions from responsible movement control agencies.
- Initiating personnel actions.

PHASE II - MOVEMENT TO RAA

9-18. Upon receipt of movement instructions; forces, individuals, and materiel are moved to the RAAs. At the RAA, the commander completes activities that he could not accomplish at the TAA. These activities include the following:

- Moving forces, individuals, and materiel to the RAA by order of TAMCA/equivalent level of command.
- Conducting washdown procedures.
- Packing and containerizing equipment and supplies.
- Affixing placards.
- Performing customs and agricultural inspection.
- Finalizing UMD and DEL.
- Preparing movement documentation and affixing military shipment labels.
- Conducting any activities not concluded in the TAA to include supply and maintenance actions and palletization and marking.

The TAA and RAA may be combined, depending on the size of the theater and combatant commander's guidance. The redeployment sequence is based on theater constraints and supported CINC's priorities. Intermediate steps and actions may be required to supplement TAA and RAA movement, to include further defining RAA activities by establishing a final POE staging area.

PHASE III - MOVEMENT TO POE

9-19. TAMCA or the equivalent level of command provides movement instructions to move forces to the POE for final processing for strategic movement. The TAMCA/equivalent level of command calls forward units according to the

redeployment TPFDD. [Chapter 7](#) discusses DACG services at the APOE, SPOE operations, and PSA responsibilities.

PHASE IV - STRATEGIC LIFT

9-20. This phase begins with wheels-up for aircraft or passage of the last marker buoy for vessels departing the SPOE. It concludes with arrival at the POD.

PHASE V - POD RECEPTION

9-21. This phase begins with arrival at the POD and concludes with departure of equipment/materiel after the final US agriculture and customs clearance from POD authorities. MTMC controls onward movement of forces/materiel from the PODs according to the redeployment TPFDD and TC-ACCIS/shipping documentation. The assigned port commander/transportation terminal unit commander and the designated MACOM receiving the forces develop a reception plan for arriving forces. When possible, commanders send advance parties to assist in coordinating the orderly processing of redeployment forces.

PHASE VI - POD ONWARD MOVEMENT

9-22. This phase begins with reconfiguration of equipment and materiel within the port staging area and at designated marshaling sites. It concludes with arrival at final destination. MACOM representatives should conduct a visual inspection of convoying equipment while in the marshaling area. Equipment requiring safety and maintenance deficiency corrections should be diverted to the supporting maintenance activity if not repairable on site.

9-23. The supporting installation's commander is responsible for the health, welfare, and support of arriving forces and for assisting with their onward movement. In this capacity, he sustains the forces and the individuals until they arrive at their destinations. This may require assisting the units in obtaining transportation to their final destinations.

REDEPLOYMENT ACTIVITIES

9-24. Depending upon the mission, the strategic redeployment process, and the size of the redeploying force, the AO capabilities may require up to three theater nodes: the TAA, RAA, and POE. The process begins after combat reconstitution when the force closes upon the TAA. The force requests the transportation agency to provide movement authorization to move from the TAA to the RAA. Based on the TPFDD and queuing in the redeployment process flow, the TA directs the force to move with the TAMCA coordinating those movements.

9-25. Commanders at POEs ensure deploying unit equipment is ready for upload. Among the activities performed are the following:

- Assembling equipment for load.

- Conducting inspection between unit and port operators.
- Assisting in correcting equipment deficiencies.
- Providing drivers for all types of equipment.

9-26. At airfields, the DACG provides liaison contact with the Air Force. This group coordinates and controls on-loading at the airfield, assembles personnel and equipment for aircraft load, and loads personnel and equipment. Personnel generally travel by air and equipment travels by sea.

9-27. At seaports, the unit's PSA coordinates and assists the port operator in receiving, processing, and loading the unit's equipment. Unit equipment is normally called forward to the port staging area before loading.

9-28. When packing up unit equipment, UMOs make sure customs officials observe the packing process and attach a seal of approval. They consolidate items whenever possible. Using pallets or containers will minimize pilferage or theft and save valuable space on ships. UMOs make sure vehicles are reduced to the appropriate configuration.

9-29. Vehicles and related equipment must be totally cleaned by owning command or adjacent units. No vehicles with fluid leaks or drips are allowed on aircraft or vessels. These deficiencies are a safety hazard and can cause damage to the airframe, vessel, or crew. Any vehicle showing up at the loading ramp with visible signs of defects will be turned back for repair or sealing. Absolutely no waivers will be granted.

9-30. Unit deployment data must also be correctly entered into TC-ACCIS before moving from RAAs. The appropriate servicing movement control activity (TAMCA, MCC, or MCT) will assist and provide UMOs with the appropriate means to update AUELs for redeployments. Load planning, cargo manifesting, and documentation help ensure a smoother flow throughout redeployment. To assist in a smooth, fast redeployment operation, units should obtain a copy of their DELs on disk prior to deployment; and use that data for redeployment. To enhance the process and to help reduce confusion, UMOs must make sure that all unit equipment or containers have the proper documentation. If equipment arrives at the APOE or SPOE without customs documentation and appropriate seals, equipment will be classified as frustrated cargo and held until unit representatives correct the deficiencies. An overview of general requirements in the redeployment process is as follows:

- Documentation for pallets, crates, CONEXs, and SEAVANs must include packing lists in six copies, a shipping label, any applicable special handling data certification forms and a [DD Form 1253](#) or [DD Form 1253-1](#).
- MILVANs and SEAVANs are not owned by the unit and cannot be stenciled. However, a [DD Form 1387](#) should be attached to the door and to the side of the container.
- Regardless of the cargo, the proper placement of military shipment labels is an essential part of the documentation required for successful redeployment. Units must make sure shipment labels are accurate and are properly placed on all

equipment. Shipment labels contain TCN codes and data needed to match labels and equipment. Two identical bar code labels are attached to each piece of equipment cargo. One is attached to the left front of each vehicle and the other on the left side door. For containers, crates, pallets, and loose pieces, the labels are placed on adjacent sides. Incorrect placement labeling will result in incorrect entry of data into the AUDEL and TC-ACCIS which will result in untimely and unnecessary delays.

- Individual or personal baggage belonging to the troops must carry a [DD Form 1253](#) or [DD Form 1253-1](#). This label or tag will be received later at the marshaling area. A [DD Form 1854](#) must also be completed later while on the plane or vessel.
- When transporting war trophies, a [DD Form 603](#) must be filled out at the marshaling area. A certificate of registration (CF 4455 or CF 4457) is required for personal firearms.
- The unit assembly area is where preparing equipment and cargo for transport begins. The success of the redeployment process depends on successful preparation. All equipment needing repair must be fixed before leaving the unit assembly area.
- After the unit has properly prepared all equipment for shipment by sea or air, it is assembled in the redeployment assembly area for further processing. (Units must make sure all hazards are removed from equipment. This includes such things as explosives and ammunition without the proper authority for movement.)
- Commanders must make sure that equipment is thoroughly clean. This is very important because organisms can be transported in all sorts of spots, even in tire tread. Carelessness here could result in the introduction of an alien disease into the US. This process must be given a 100 percent effort. All equipment will undergo inspection by customs and USDA officials. Cargo or equipment that fails to meet inspection will be deemed frustrated and pulled from line. The deficiency will have to be corrected after which the entire process begins again.
- Units secure internal loads to prevent shifting and damage. They weigh and mark all equipment redeploying by air. They also make sure all appropriate placards and convoy numbers are in place and prepare and place correct movement documentation on all equipment. The TAMCA should have all forms needed for redeployment. If forms are not available, TAMCA will provide alternate directions or solutions to follow.
- All vehicles and major equipment must be marked with a DD Form 2271, a [DD Form 1253](#) or [DD Form 1253-1](#), packing list in six copies if a vehicle has containerized internal loads, and a special handling data certification.
- In addition to customs acceptance of equipment, customs inspectors at the POE inspect personnel and baggage documentation. The aircraft commander must complete a aircraft general declaration form (CF 7507). All personnel must also complete a [DD Form 1854](#).

- Units ensure that their vehicles and equipment have stenciled on them, in 2-inch letters, the UIC and SUN for vehicles, MILVANs, or pallets. Cross-leveling will be completed at the TAA. Here all equipment is checked for proper packing/securing of internal loads, for correct documentation and seals, for removal of all ordnance, for serviceable lifting shackles on all vehicles, for correct fuel levels, and for such maintenance and safety concerns as properly operating lights, brakes, and correct fluid levels. Equipment will also be checked for proper marking and weighing data, appropriate placement of placard and warning signs, shipping labels, and proper documentation of vehicles and equipment, pallets, crates, MILVANs, SEAVANs, and accompanied baggage.
- Individual personnel not moving under a TPFDD ULN may be coordinated for movement by their parent unit through the TAMCA representative based on supported CINC guidance. Individual redeploying personnel remain under the administrative/logistical control of the parent unit until redeployed. In all cases, the primary method of redeployment is based upon the TPFDD process, identified by ULN. Other methods of deploying cargo and personnel not scheduled for redeployment with the main body should be done through established AMC procedures by requesting additional ULN allocation through the JOPES procedures or on an exception basis by signing over cargo for later strategic lift with units moving to the same destination.
- The unit is responsible for actions at and in support of the TAA. This includes completing all supply actions, identifying redeploying assets by mode, and preparing cargo for movement. The AUDEL is updated for redeployment.
- The TA is responsible for movement of force into the RAA and actions at and in support of the RAA. This includes all predeployment preparation not conducted in the TAA, final changes to the AUDEL, and final unit predeployment equipment preparation. A final sterile area may be required by the theater. The redeployment order will specify if and how a sterile area will be used. The sterile area is a location near the POE for controlled holding of custom-cleared cargo. The military customs inspector/MP will facilitate and control the use of this area. The TAMCA will call units forward from the sterile area.

NOTE: [DA Form 5748-R](#) is an authorized substitute document for DD Form 1750. Refer to [CFR 49](#) and AFJMAN 24-204 for more information.

9-31. The marshaling area is the final site en route for redeployment in which the unit has responsibility for unit equipment. This site is outside the APOE or SPOE to help control congestion and confusion as well as to provide adequate space for sorting equipment and personnel. Depending on available space at the port, it may be the same location as the staging area. Here all external equipment surfaces are cleaned and inspected by customs and all cargo, vehicles, and equipment are placed in chocks for onward movement. Once equipment is placed at the marshaling area, drivers can return to their parent units and HN assets can be turned in.

9-32. The next processing area is the staging area SPOE and the alert holding area for

the APOE. Equipment at this site is jointly inspected by appropriate personnel. Port personnel inspect equipment being shipped by vessel, and personnel and DACG inspect equipment going by air. Following inspection, the port commander or the DACG assumes control. Customs personnel, usually MPs, conduct a final inspection of equipment prior to loading at the POEs. Port or airfield personnel position equipment for upload onto vessels or aircraft. The equipment and personnel are then placed in sterile areas and not permitted to depart.

NOTE: It is possible that unit personnel may be required to assist in the loading process. If this should occur, unit personnel should follow the instructions of the OIC/NCOIC of the port or airfield operation.

9-33. At the APOD, the call forward area requires joint inspections. After the joint inspections have been completed, unit equipment will be marshaled to the ready line and chalked for aircraft loading. As the equipment is called forwarded and loaded onto the aircraft, the Air Force assumes responsibility for unit equipment.

9-34. At the SPOD, the port commander will assume responsibility for unit equipment at the staging area. Personnel and cargo manifests are reviewed for accuracy and corrections are made.

9-35. After loading onto strategic lift, unit equipment and cargo responsibility is transferred from the port commander to the vessel master or from the unit commander to the aircraft commander.

CONUS POD ACTIVITIES

9-36. Customs and USDA inspectors check, approve, and issue customs and agriculture clearances. Personnel and equipment manifests are received. Stevedores or TALCE personnel then begin to process the inbound shipment and clear the POD. The port staging area is the initial CONUS off-load site. Equipment may be held pending onward movement.

9-37. From the port staging area unit representatives will assume responsibility for unit equipment and move it to a unit marshaling area. Unit personnel reconfigure equipment for continued movement to the supporting installation or HS. UMOs are responsible for coordinating the return of all personnel and equipment with the supporting ITO for movement back to demobilization stations, equipment concentration sites, or HSs. This includes preparing necessary convoy clearances and obtaining approval for throughput to HS. Vehicle maintenance teams will prepare vehicles for convoys. Rail or commercial highway representatives will be on hand while the port support activity uploads equipment for commercial transport.

9-38. Follow-on locations for soldiers redeploying as individuals may be to designated CDCs for soldiers scheduled for separation or to follow-on assignments designated by the PERSCOM commander. The CDC locations are designated by the TRADOC commander.

9-39. Follow-on locations for civilians are normally the locations from which they originated. They will redeploy using the same support structure as used by soldiers redeploying as individuals.

9-40. Follow-on locations for materiel being returned to CONUS or being redistributed elsewhere are determined through the automated redistribution process or through management decisions. This information is developed by the Army Materiel Command, HQDA (DCSLOG), and the Depot Systems Command.

9-41. Units redeploy in three increments: advance party, main body, and rear detachment. The advance party prepares for their arrival both at POD, DMS, and destination. The bulk of the personnel and designated equipment redeploy back with the main body. The rear detachment remains in the theater (usually not to exceed 25 percent of the unit's authorized personnel (preferably volunteers)) to maintain property accountability, perform unit maintenance, provide oversight of supply support, and interface with movement control as the balance of their equipment is processed for strategic sealift. Once their equipment has been processed, TAACOM directs their redeployment by strategic airlift. Upon arrival at the final destination, the unit will perform the following:

- Personnel are moved to demobilization stations/CDCs.
- Equipment is off-loaded.
- A 100 percent inventory is conducted.
- All equipment is cleaned.

Units will also conduct maintenance on equipment, return loaned material and equipment, and, based on command guidance, cross-level equipment. The redeployment process concludes when UMOs update their AUDEL and process the data into COMPASS. The success of any redeployment process requires cooperation and patience. The ultimate success of the procedure is measured by the safe and timely return of all equipment and personnel to a unit or HS.



[RDL](#) [Table of](#) [Document](#) [Download](#)

[Homepage](#) [Contents](#) [Information](#) [Instructions](#)

Appendix A

Documentation

For unit deployments, cargo is documented by using a [DD Form 1387](#). The MSL consists of bar coded information that contains a TCN (see [Figure A-1](#)). The TCN provides ITV and helps to locate UMD stored and maintained on a computer file. Units maintain their UMD on an AUEL. MTMC helps manage and control cargo movement to and through the defense transportation system.





1 TRANSPORTATION CONTROL NUMBER  W26DDJ54320111XXX	2 POSTAGE DATA										
3 FROM W45QFS FT STOCKTON ATTN: ANGL-TR-SH ATTN: ANGL-R-SH FT STOCKTON TX 76789-5000	4 TYPE SERVICE										
5. SHIP TO / POE FT EUSTIS ATTN: ATZF-NT FT EUSTIS NEWPORT NEWS VA 23604-5300	6 TRANSP PRIORITY										
7 POD	8 PROJECT KMK										
9 ULTIMATE CONSIGNEE OR MARK FOR  W26DDJ FT EUSTIS ATTN: ATZF-NT FT EUSTIS NEWPORT NEWS VA 23604-5300	<table border="1" style="width: 100%; border-collapse: collapse;"> <tr> <td style="width: 33%; padding: 2px;">10 WT THIS PC 10</td> <td style="width: 33%; padding: 2px;">11 RDD 12/19/98</td> </tr> <tr> <td style="padding: 2px;">12 CU THIS PC 8</td> <td style="padding: 2px;">13 CHARGES 784.99</td> </tr> <tr> <td style="padding: 2px;">14 DATE 12/19/98</td> <td style="padding: 2px;">15 FMS CASE</td> </tr> <tr> <td colspan="2" style="padding: 2px;"> 16 PIECE NO.  9 </td> </tr> <tr> <td colspan="2" style="padding: 2px;">17 TOTAL PIECES of 10</td> </tr> </table>	10 WT THIS PC 10	11 RDD 12/19/98	12 CU THIS PC 8	13 CHARGES 784.99	14 DATE 12/19/98	15 FMS CASE	16 PIECE NO.  9		17 TOTAL PIECES of 10	
10 WT THIS PC 10	11 RDD 12/19/98										
12 CU THIS PC 8	13 CHARGES 784.99										
14 DATE 12/19/98	15 FMS CASE										
16 PIECE NO.  9											
17 TOTAL PIECES of 10											
FORM APPROVED OMB NO 0704-0188											

Figure A-1. Military Shipment Label

Before the unit commander gets deployment specifics through the movement order, he has

already submitted accurate movement data to the appropriate MACOM through AUDEL updates. When he gets the specifics, the unit commander submits a final listing of the modes of travel for each item on the DEL. The ITO will, in turn, submit the updates to MTMC. At this time, MSLs are printed for each item on the DEL that will travel by surface or air. Because labels are printed from the DEL, they are only as accurate as the data the units submit.

MSLs are obtained through the installation UMC. The deploying unit affixes them to the unit cargo. PBCRs read the labels as each piece of cargo passes through the various segments of the transportation pipeline. The PBCR, a hand-held microcomputer, is uploaded into another computer containing the UMD. It is used to manage, control, and provide ITV of the cargo.

TRANSPORTATION CONTROL NUMBER

A-1. The TCN for a piece of cargo consists of the UIC and a five-digit shipment unit number (see [Figure A-2](#)). This number is on the AUDEL/DEL. This TCN is for unit deployments only. See also MILSTAMP DOD Reg 4500.32-R, [Appendix G](#).

SAMPLE ARMY TCN: AWABCAA00D12340XX

SVC CODE	UIC	FILL	FILL	SUN	UNIT MOVE	SPLIT
1	2-7	8	9	10-14	15	16-17
A	WABCAA	0	0	D1234	0	XX

Accepted by Joint Staff and USTRANSCOM

Figure A-2. Sample Transportation Control Number (Unit Move).

SHIPMENT UNITS

A-2. A TCN identifies a shipment unit (based upon TC-ACCIS SUN). The shipment unit is a piece of cargo, equipment, or container that moves through the transportation system as a single package. The contents of a shipment unit are not normally separated until the cargo reaches the final destination. For example, a unit deploys a 5-ton truck and trailer as two separate shipment units because the prime mover is likely to be separated from its trailer during rail or ship loading.

CARGO IDENTIFICATION

A-3. The following cargo documentation steps must occur for a smooth deployment and redeployment of vehicles and equipment.

MARKING CARGO

A-4. Deploying units must ensure that cargo is properly marked. The deploying unit must perform the following:

- Affix MSLs on the cargo.
- Affix shipment unit packing list to cargo.
- Affix HAZMATs warning labels or placards (as appropriate) to cargo.
- Prepare and affix purging statement to bulk fuel tanks.

STENCILING/MARKING EQUIPMENT

A-5. Stencil the UIC and SUN on all major end items and special handling cargo identified on the AUDEL/DEL as "D" and "F" records. Also stencil the UIC and SUN on all secondary loads that can be moved as separate items. The SUN will be the same as that of the primer mover, but will contain an "E" in the first position rather than a "D">. For example, containers nested in the back of a 2 1/2-ton truck (prime mover) with a UIC/SUN of WABCAA-D0001. The stenciled UIC/SUN must match those on the MSL>. Until the TC ACCIS software is changed, a separate ULN should be assigned down to company level for TPFDD movement so the unit UIC/SUN remain the same for each deployment. Otherwise, equipment must be restenciled. Equipment will be stenciled/marked as follows:

- Stencil the UIC/SUN and mark the gross weight (stencil, tape, and so forth) on all crates, pallets, and unit-owned containers. Put the weight directly under the UIC/SUN.

NOTE: Units do not own Common User containers. Common User containers are normally defined as 20-foot ISO containers (to include MILVANs) owned, managed, and controlled by TRANSCOM. These containers are prepositioned at installations for the units to move equipment to deployment locations. Immediately afterwards, these containers are put back into the transportation system. Therefore, these containers should not be stenciled or permanently marked. Instead, only MSLs and packing lists are affixed to the outside door and adjacent side of the container.

- Stencil the UIC and SUN on the vehicles front and left side in 2-inch lettering with contrasting camouflage colored paint. If bumpers do not exist or are too small, such as on MHE, aircraft, floating craft, and construction equipment, stencil the equipment with the UIC/SUN as follows:
 - Stencil the UIC and SUN on the left side of MHE on the engine housing or in plain view on the left side of the piece of equipment.
 - Stencil fixed-wing aircraft on the left side of the tail section below the

aircraft ID number.

- Stencil rotary-wing aircraft on the left side of the engine housing.
- Stencil the UIC and SUN on the stern of floating craft above the water line.
- Mark bundles, loose pieces, and miscellaneous items accordingly.
- Mark classified or protected cargo according to proper guidelines (see [Appendix F](#)).

NOTE: The deploying unit will fabricate a plaque and mount it in a visible location on equipment that does not have space for marking.

USING MILITARY SHIPMENT LABELS

A-6. MSLs contain the bar-coded TCN and the data needed to match labels and equipment (see [Figure A-3](#)). Two identical bar code labels are put on each piece of equipment. One label is put on the left front of each vehicle. The other label is put on the left side or in a corresponding location of each piece of equipment. On containers, crates, bundles, and loose pieces, labels are put on adjacent sides.

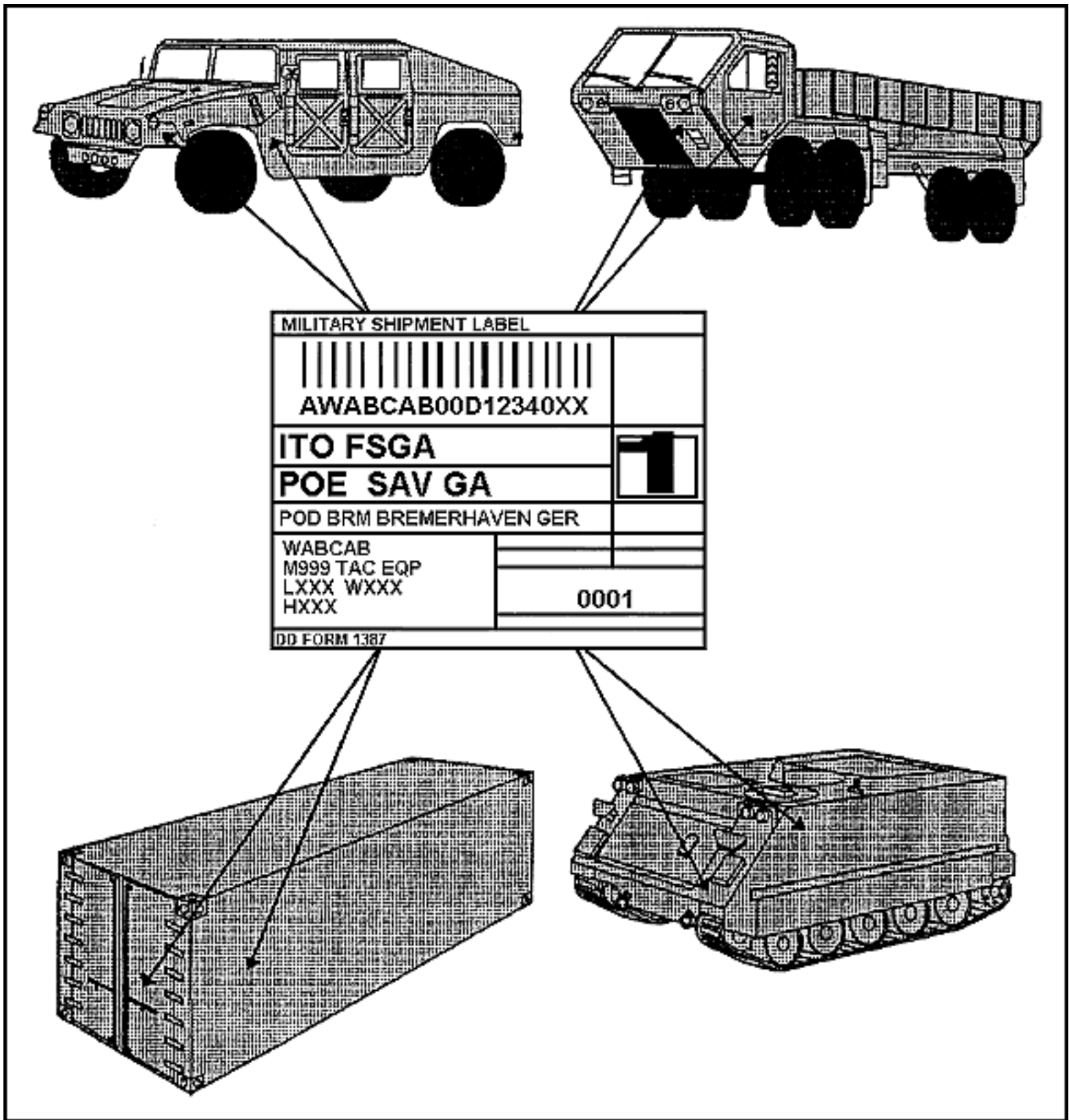

Figure A-3. Shipment Label Placement

A-7. Do not cover MSLs with tape, acetate, or any other material. Bar code readers will be unable to read the label's bar code data. The UMO (or other designated personnel) must verify the MSLs against the DEL. MSLs must match the vehicle, equipment, or cargo on which they are applied. Since mismatched MSLs cause significant delay at the POE, discrepancies or changes should be brought to the ITO's

immediate attention. See [Table A-1](#), for other deployment documentation requirements.

Table A-1. Deployment Documentation Requirements

<u>COMMON FOR OVERSEAS MOVEMENTS--</u>	<u>VEHICLES(1)</u>	<u>CONTAINERS</u>	<u>PALLETS, CRATES, CONEXES</u>	<u>PERSONAL BAGGAGE</u>
Warning Placards (when applicable) (for hazardous cargo)	X	X	X	
Signature & Tally Record (DD 1907) (when applicable) (for sensitive cargo accountability)	X	X	X	
UIC and Shipment Unit Number (Stenciled)	X	X(8)	X	
Military Shipment Label (DD 1387)	X(7)	X(7)	X(7)	
Packing Lists (DD 1750 /DA 57438R)	X(6)	X	X	
Security Seals	X(2)	X	X(3)	
o* Military Custom Label (DD 1253) or Tag DD 1253-1)	X	X	X	X
o* U.S. Customs Accompanied Baggage Declaration				X
+* Decontamination Tag (DD 2271)	X	X	X(3)	
± Commanders Certificate (no ammo or body parts)	X			

<u>±</u> Certificate of Registration (CF 4455 or 4457) (when applicable)				X
<u>±</u> Registration of War Trophy (DD 603) (when applicable)			X	X
<u>AIR--</u>				
Passenger Manifest (DD Form 2131)				X
Cargo Manifest (DD Form 2130 Series)	X		X(5)	
Pallet Identifier (AF Form 2279) or Compatible Form			X(5)	
Special Handling Data/Certification (DD 1387-2) (for sensitive and classified)	X	X	X	
Shippers Declaration for Dangerous Goods (for hazardous, sensitive, and classified)	X	X	X	
Military Shipment Label (DD 1387)	X(7)	X(7)	X(7)	
<u>SEA--</u>				
Military Shipment Label (DD 1387)	X	X	X	
Container Packing Certificate		X	X(3)	
Shipping Paper and Emergency Response Information for Hazardous Materials Trans-ported by Government Vehicles (DD 836)	X			

<u>RAIL/COMMERCIAL TRUCK--</u>				
TCMD (DD 1384 or Government Bill of Lading (GBL) (Prepared by the Transportation Office)	X	X	X(3)	
Military Shipment Label (DD 1387)	X(7)	X(7)	X(7)	
<u>CONVOY--</u>				
Military Shipment Label (DD 1387)	X(7)	X(7)	X(7)	
Convoy Clearance Request (DD 1265)	X			
Special Hauling Permit (DD 1266) (when applicable)	X			
Motor Vehicle Inspection (DD 626) for vehicles carrying ammo	X			
Shipping Paper and Emergency Response Information for Hazardous Materials Trans-ported by Government Vehicles (DD 836)	X			
<u>NOTES:</u>				
* Asterisk identifies items that Customs or USDA inspectors may substitute CF for DD forms.				
o Redeployment Only				
+ Wartime Redeployment				
(1) Includes major weapon systems and aircraft				

(2) Seal affixed to all access areas

(3) CONEX Only

(4) When secondary load on nonorganic military or commercial vehicle

(5) 463L pallets

(6) For vehicles when secondary loads are not unitized with individual packing lists

(7) For all vehicles and consolidated shipments units (containers, CONEXs, and 463L pallets) deploying OCONUS or on EDREs/SEDREs, regardless of mode, military shipment ([DD Form 1387](#)) will be applied on two adjacent sides. For vehicles, place labels on the front left bumper or suitable location in the same vicinity, place the second label on the left door or door area as appropriate.

(8) Only stencil/mark unit owned containers.

SHIPMENT UNIT PACKING LIST AND LOAD DIAGRAM

A-8. All vehicles, containers, warehouse pallets, 463L pallets, crates, and bundles must display a separate [DD Form 1750/DA Form 5748-R](#) (packing list) showing its complete contents (see [Figure A-4](#)). Packing lists are not required for items that do not need identification, such as empty vehicles, nested cans, or banded shovels. However, these items must be listed on the load diagram if they are loaded in a truck or container. A packing list is not always required for a container if it already has a list of its complete contents on it. An example is an inventory of tools or a parts list such as those found in supply bulletins. Do not list classified materiel on the packing lists. Personnel will prepare five copies of the packing list for distribution. Distribute copies as follows:

SHIPMENT UNIT PACKING LIST AND LOAD DIAGRAM				PAGE	
For use of this form, see FM 55-65, the proponent agency is TRADOC.				OF	
1 DEPLOYING UNIT A Co. 1-10 IN WABCAB		2 UIC OR BUMPER NO A-41		3 TCN OR SEAL NUMBER AWABCAB00D12340XX	
4 SHIPMENT UNIT DESCRIPTION MS23A2, TRK, CGO 5TON X40794.36				5 DATE PACKED	
6 LENGTH 311		7 WIDTH 98	8 HEIGHT 121	12 LOCATION OF CG	
9 CUBE 2135	10 EMPTY WEIGHT 20930	11 LOADED WEIGHT 27904			
13. PACKING LIST					
CARGO LOC NO <i>a</i>	CONTENTS (Description and Nomenclature) <i>b</i>	TYPE PKG. <i>c</i>	PKG. QTY. <i>d</i>	PKG. WEIGHT <i>e</i>	TOTAL PKG WEIGHT
1	TENT, GP MED	PLT	1	250	250
2	POLES & MISC EQUIPMENT	BX	1	50	50
3	LIGHT SET, ILLUM	BX	2	50	100
4	GEN SET, 3KW	3EA	2	3162	6324
BBM	120 ft 4 X 4 100 ft 2 X 4 7 lb 2 X 4 4 CGU-1 CGO Straps				250
14. CERTIFICATION. This certifies that items listed hereon are contained within the specified packages.					
<i>a</i> TYPED NAME SMITH, JOHN A.		<i>b</i> GRADE SGT	TITLE SQUAD LEADER		
<i>d</i> SIGNATURE				DATE	

DA FORM 5748-R, MAR 89

Figure A-4. Sample DA Form 5748-R (Front)

15. LOAD DIAGRAM [Sketch cargo storage in space below].

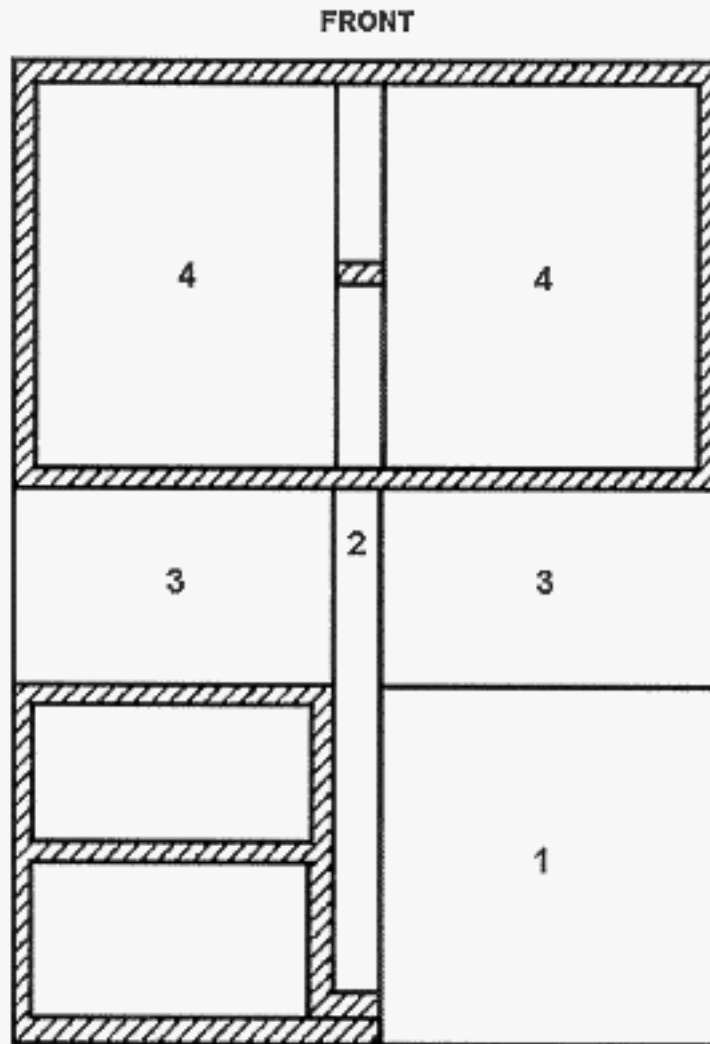

16 REMARKS

**Tent is banded to warehouse pallet
 Poles are banded together
 Generator sets have been drained and cleaned**

REVERSE OF DA FORM 5748-R, MAR 89**Figure A-4. Sample DA Form 5748-R (Back)**

- One copy is filed in the movement plan.
- One copy is put on the outside of the shipment unit where it is easily visible or accessible. (This copy is put inside a weatherproof covering.)
- One copy is put inside the shipment unit.
- One copy is prepared for the unit's representative (liaison team or supercargo).
- One copy is retained by the hand receipt holder.

The DA form should be prepared according to the following instructions:

Block 1. Enter the name of deploying unit.

Block 2. Enter the UIC or bumper number.

Block 3. Enter the TCN or container seal number.

Block 4. Enter a general shipment unit description and use phrases such as "NBC defense equipment," "motor maintenance spare parts," or "office supplies." (Do not use terms such as "MISC.") Include LIN and applicable index number.

Block 5. Enter the date the form is compiled/date packed.

Block 6. Enter length of shipment unit.

Block 7. Enter width of shipment unit.

Block 8. Enter height of shipment unit.

Block 9. Enter cubic feet of shipment unit.

Block 10. Vehicle/shipping containers enter empty weight.

Block 11. Vehicle/shipping containers enter loaded weight.

Block 12. Enter location of center of balance.

Column 13a. Enter cargo location number (See note at [Block 15.](#))

Column (a). Number contents sequentially. Use this same number to identify the cargo compartment view shown on the load diagram.

Column (b). Enter nomenclature of contents and line number from property book. Highlight all HAZMATs.

Column (c). Enter the type of package. Accepted abbreviations include:

Battery	btry
Cylinder	cyl
Piece	PC
Palletized	PT

Column (d). Enter unit of issue such as "1 ea."

Column (e). For hazardous packages only: Enter the weight of each package separately. Then enter the total package weight (weight, volume, or otherwise appropriate measurement).

Column for non-HAZMATs. Enter total package weight.

NOTE: The bottom of the last page must contain the following information:

1. BBPCT information. For example, special crating and/or internal packing materials (be specific).
2. Total weight in pounds.
3. Statement: "This is to certify the above named materials are properly classified, described, packaged, marked, and labeled and are in the proper condition for transportation according to the applicable regulations of the Department of Transportation."

Blocks 14a, Enter the name, grade, title, signature of person preparing the form and date in Block e. If [Block 13b](#) includes hazardous cargo, then the unit's hazardous cargo certifying official will sign under the hazardous cargo statement.

Block 15. A load diagram is shown for all items that require a packing list. The load diagram must show the following:

- a. A diagram of the location of each item loaded.
- b. A brief description of the load, including potential loading problems and instructions.
- c. The type of container or vehicle.
- d. All blocking, bracing, and packing materials needed to secure the cargo within the shipment unit.

Block 16. Remarks. Self-explanatory.

[RDL](#)[Table of](#)[Document](#)[Download](#)[Homepage](#) [Contents](#) [Information](#) [Instructions](#)

Appendix B

Deployment Training

If a unit does not participate in large scale exercises often enough to train the unit adequately in deployment procedures, commanders must find alternate methods of training to ensure readiness. Training should focus on particular segments of the deployment operation or key personnel and should rehearse or exercise that one element. Deployment training usually requires a great deal of simulation and challenges commanders to provide realism. Training exercises may range from a brigade S/EDRE to testing the load plan of any given vehicle in the unit.

The unit commander must ensure that all personnel are trained and prepared for deployment. He must also ensure that certain key individuals or elements in the unit are properly trained to carry out their special deployment duties. This appendix lists those who require special training and some of the key skills that they must learn.

UNIT MOVEMENT OFFICER

B-1. In each company size unit, a unit movement officer (E6 and above) and an alternate should be appointed on orders. They must be trained by the unit or a service school and be thoroughly familiar with the following:

- The contents of this manual.
- Air Force/Army airlift operations.
- The roles and duties of the UMO and UMC.
- The transportability of the unit's organic equipment.
- The characteristics and capabilities of the types of vessels, aircraft or railcars the unit may use to deploy.
- Highway, rail, and port operations.

B-2. Formal training for unit commanders, UMOs, and NCOs in unit deployment is available through the JSDTC. JSDTC offers several resident courses including the following:

- Air Deployment Planning Course (AMC certified).
- Unit Movement Officer Deployment Planning Course.
- Strategic Deployment Planning Course.
- TC-ACCIS.
- Mobilization Deployment Planning Course.

B-3. JSDTC also conducts mobile training team activities on request. To obtain information on course offerings, mobile training teams, and related doctrine, contact JSDTC, ATTN: ATSP-TDJ, Fort Eustis, VA 23604-5363 or call DSN 927-2039 or commercial (757) 878-2039.

B-4. The Army Reserve Training Center (DSN 280-7277 or commercial (608) 388-7277) conducts the Unit Movement Officer Training and Mobilization Planning Course.

UNIT LOAD TEAMS

B-5. Each unit must have an appropriate number of personnel trained on vehicle preparation and aircraft and rail loading and unloading techniques. This training will include the following:

- Preparation of vehicle load plans.
- Preparation of vehicles for shipment by reducing operational dimensions, protecting fragile components such as windshields and mirrors, and weighing and marking procedures for air and rail modes.
- Tie-down procedures for vehicles, aircraft, and railcars.
- Operation of unit vehicles in conditions simulating loading and unloading techniques for aircraft and rail.

HAZARDOUS CARGO CERTIFYING OFFICIAL

B-6. When preparing, packing, and marking material for shipment, special certification is required to ensure personnel follow safety procedures according to [AFJM 24-204](#) or [CFR 49](#). Improper procedures could cause loss of life or equipment. Each unit with air transportable equipment should have at least one school-certified person to certify hazardous cargo. [AR 55-355](#) gives information on formal certification. Hazardous cargo certification teams visit most installations annually or semiannually. (Consult the ITO for scheduling details.) Regardless of whether or not the unit has anyone who is school qualified, the movement planners should be familiar with the contents of [AFJM 24-204](#) and [CFR 49](#). MIL-STD-129J and [DA Pamphlet 740-1](#) contain additional packing assistance.

EMERGENCY DEPLOYMENT READINESS EXERCISE

B-7. An EDRE is designed to exercise the movement plans of a unit or higher level to deploy to an overseas theater of operations. All deployable units normally participate in an EDRE annually. If executed realistically, an EDRE can be the most valuable evaluation process for commanders at all levels to determine their strengths and weaknesses in a deployment. An EDRE can be conducted at the company level or as high as the highest level of command. [FORSCOM Directive 525-5](#) contains more information on conducting EDREs. To make training realistic and effective,

commanders must do the following:

- Accomplish actual issue of basic loads.
- Ensure that units physically load everything needed for deployment.
- Adhere strictly to proper packing and documentation procedures so all potential problems and exact amounts and types of material may be identified. Some executing procedures may have to be simulated if the exercise is not intended to actually extend beyond the home installation.
- Use external evaluators to ensure adherence to standards.

A properly executed EDRE identifies the need for support personnel, maintenance assistance teams, mess support, security, PSA/DACG, and marshaling and staging area operations.

B-8. A successful EDRE gives each command level the opportunity to experience the challenge associated with equipment readiness and equipment transfers in deployment. Units with a short notice deployment may have to acquire equipment from sources on the installation. Units must consider the inspection criteria for receiving filler equipment, training needs, new lines of PLL (if filler equipment is issued in lieu of an authorized item), and subsequent alterations to the unit movement plans.

B-9. Commanders must develop adequate criteria for units and activities to evaluate their deployment readiness. Procedures must be devised for following up on deficiencies and corrective actions. Every attempt must be made to learn lessons of past exercises and deployments.

[RDL](#)[Table of](#)[Document](#)[Download](#)[Homepage](#) [Contents](#) [Information](#) [Instructions](#)

Appendix C

Vehicle Preparation

Efficient equipment preparation for movement is a unit responsibility. Unit personnel reduce vehicles according to mode of transportation and the carrier's additional instruction. PSA/DACG personnel may reduce vehicles so they will fit into cargo areas whose particularly low overhead clearance may demand maximum reduction. This appendix contains procedures for reduction of unit vehicles.

EFFICIENT CARGO PREPARATION

C-1. Efficiently preparing cargo saves valuable cargo space aboard vessels and aircraft. Other advantages are greater integrity of unit equipment, less cargo handling, less chance for unit equipment to become delayed or lost, and significant cost savings.

C-2. Built-up vehicles will not be transported on vessels or commercial conveyances without MACOM approval. These types of vehicles typically have overhead clearance problems along rail lines and in vessel compartments. When built up vehicles are permitted, for example, a temporary substitute for a TOE authorized shelter, the new dimensions must be entered on the AUDEL. When mounted on a vehicle, the built-up shelter height must not exceed the height of the authorized shelter. Authorized shelter heights are designed to accommodate both the vehicles vertical balance and overhead clearance on selected transportation modes.

VEHICLE REDUCTION STANDARDS

C-3. Prepare unit cargo (vehicles and equipment) for shipment according to the mode of transportation and the type of move. If a unit moves organically, it moves vehicles in an operationally reduced configuration, such as mirrors mounted and windshields up. Reduce loads according to [TB 55-46-1](#) and the movement order. Further reduction specified by the movement order occurs in the POE staging area. RC units that convoy to a MS before deployment will maximize use of their organic cargo capacity by reducing loads for the deployment at the MS. Depending on the strategic lift asset for deployment, full reduction may or may not be required.

C-4. Make every effort to support the commander's concept of operations. When preparing vehicles for shipment, unit personnel must be sure that equipment conforms to clearance and space restrictions. Personnel must do the following:

- Reduce vehicle length and width by folding in side-mounted mirrors and

removing storage baskets that overhang the vehicle's fixed dimensions.

- Remove antennas.
- Keep windshields and cab canvas in the up position.
- Leave exhaust stacks in place.
- Reduce height as needed for rail clearance. Check with the ITO.
- Reduce the length, width, and height of the vehicle only when specified in the movement order.

PREPARATION OF VEHICLE

C-5. Take the following steps to prepare the vehicle:

- Thoroughly clean the vehicle.
- Ensure the vehicle is mechanically sound, free of leaks, drips, and other operational defects.
- Fill fuel tanks only to three-quarters of their capacity. Any additional fuel increases the chance for spillage. Do not put hazardous labels or placards on vehicles for fuel in the tanks.
- Do not fill trailer mounted equipment containing combustion engines, such as generator sets, to more than one-half of their fuel capacity.
- Ship 5-gallon fuel cans three-quarters full of diesel fuel if they are shipped in approved vehicle storage racks. Inspect fuel cans for serviceable lid gaskets, leaks, and other defects prohibiting their use as fuel containers.
- Do not leave removable crew served weapons, such as spare barrels and other sensitive items, mounted or stored in the vehicle. Instead, consolidate them and place in a secure container. Seal the container and lock it with an appropriate locking device.
- Equip all vehicles with serviceable and proper lifting/tie-down devices or shackles. Remove T hooks from combat vehicles and replace them with screw pin shackles.
- Secure ignition keys to the steering wheel with wire. The wire must be long enough to reach the ignition. Give copies of container keys to the unit liaison team or supercargoes accompanying the cargo.
- Do not cover headlights, windshields, or mirrors with tape.
- Ensure fire extinguishers are in the approved mounting bracket if they are kept with vehicles during shipment.
- Keep driver compartments and steering wheels unlocked.
- To preclude moisture damage to radios, store them in secured containers. If radios are shipped mounted in the vehicles, secure them with a padlock and chain; then cover them with plastic. Treat COMSEC equipment as classified cargo (see [Appendix F](#)).

If required for height reduction, lower canvas cab tops . Remove and box the frames

for the cab canvas. Stow them only in the front cab of their respective vehicles. Keep the canvas threaded through the top windshield channel. Fold down the windshield with the canvas wrapped over the windshield and secure with manila rope. The method and degree of protection are left to the unit commander's discretion.

C-6. If removing exhaust stack extensions, protect the opening from weather and debris when the vehicle is not in operation. Use a tin can large enough to fit over the bottom exhaust stack pipe. Attach a wire to the can and exhaust stack bracket so the can may be removed and not lost when the vehicle is in operation. Place a shoe tag on the ignition switch or steering wheel to remind the operator to remove and install the can as appropriate..

C-7. When nesting equipment or placing cargo into unit vehicles, adhere to the following guidelines:

- Maximize use of all vehicles cargo capacity, particularly cargo vehicles and trailers. If a trailer is nested in the back of a cargo truck, load cargo under and around the trailer.
- Do not exceed the payload capacity.
- Securely restrain the equipment and cargo in the vehicle body or chassis.
- Ensure there is no metal-to-metal contact of loaded cargo. For example, a container loaded in the bed of a 5-ton cargo truck must have plywood between its bottom and the metal cargo bed.
- After loading cargo into the cargo bed, cover it with canvas. Secure the canvas by lashing with manila rope. If steel strapping must be used, use enough padding to prevent damage to the canvas.
- Update the AUEL if cargo loaded in a vehicle increases the dimensions or adds vehicle weight.
- Box OVE and remove parts when practical. Store them aboard the vehicle for easy access at the POD. The OVE can be secured best in the vehicle OVE box. Lock or band the box itself. Store OVE and parts in the vehicle cab or under seat compartments (as long as seats can be secured). Or place OVE and parts into boxes or small crates and place the crates in the cargo bed. Mark boxes or crates with the vehicle's UIC and SUN.
- Stow acetylene and oxygen tanks on a separate wooden pallet. Label tanks according to [CFR 49](#) and clearly mark with the prime mover UIC/SUN.

For more specific information, consult the applicable transportation summary manual.

[RDL](#)[Table of](#)[Document](#)[Download](#)[Homepage](#) [Contents](#) [Information](#) [Instructions](#)

Appendix D

Hazardous Cargo

All hazardous cargo must be prepared and documented according to appropriate regulations. Hazardous cargo improperly prepared for shipment can delay shipping and cause mission failure. When equipment is packed and loaded, HAZMATs must be identified and properly segregated. All HAZMATs moving by air must be certified in accordance with [AFJM 24-204/TM 38-250/NAVSUP Pub 505/MCOP 4030.19F/DLAM 4145.3](#). Follow steps outlined below for surface shipments.

DOCUMENTING HAZARDOUS MATERIALS FOR SURFACE SHIPMENT

D-1. The following steps may be used as a guide when shipping HAZMATs. Use this guide with [CFR 49](#), Parts 100-177.

- Determine the proper shipping name and ID number. The shipper must select the proper shipping name of the materials as listed in the Hazardous Materials Table.
- Determine the hazard class or classes. Materials are classed by the proper name in the Hazardous Materials Table. (Hazard class definitions are found in [CFR 49](#)). If the materials have more than one hazard, classify the material based on the order of hazard precedence.
- Determine the modes of transport to the destination area. The shipper must ensure that the shipment complies with the various modal requirements. Mode of transport affects the packaging, quantity per package, labeling, and segregation of HAZMATs.

NOTE: Most countries enforce the IMDG Code for import surface shipments of HAZMATs. DOT regulations require HAZMATs to be classed and labeled according to [CFR 49](#).

- Select the proper labels and apply as required. Refer to the proper section of the Hazardous Materials Table.

NOTE: Labels are not needed for fuel in vehicle fuel tanks.

- Determine and select the proper packaging. When selecting an authorized container, consider the quantity per package, cushioning material, and proper closure, reinforcement, pressure, and outage, as required.

- Mark the packaging. Apply the required markings, proper shipping name, and ID number, as required, and the TCN or UIC/SUN.
- Prepare packing lists according to the instructions in [Appendix A](#). List HAZMATs packed inside containers or vehicles first (refer to Steps 1 through 3).

NOTE: Only authorized abbreviations are permitted for HAZMATs. Refer to [CFR 49](#).

- Determine the proper placards. Refer to [CFR 49](#).
- Determine segregation requirements for HAZMATs. HAZMAT may be shipped by rail, ocean vessel, highway, or a combination of these modes. If two or more modes transport the cargo, segregation standards for each mode used must be met.
- Ensure water commodity and special handling codes are used on the AUDEL/DEL.
- Ensure compliance with DOT emergency response guide book (DOT P5800).

PREPARING SHIPMENT UNITS OF HAZARDOUS MATERIAL FOR SHIPMENT

D-2. Rules governing segregation requirements for hazardous cargo must be met. When in doubt about shipping any hazardous or questionable materials, separate them from the rest of the unit cargo. If the hazard class or classes cannot be identified, consult the installation safety office or the ITO. Failure to follow these rules will result in sealed or locked shipping containers being opened, noncompatible cargo being removed from vehicle cargo beds, and loads being separated from prime movers. These actions not only hamper cargo accountability techniques but also increase through-port work load and congestion. The deploying unit must be sure of the following:

- Loose ammunition and explosives are removed from all containers and vehicles. Ammunition is not permitted into the port or aboard vessels without prior authorization from MTMC.
- Vehicle fuel tanks are only three-quarters full. This is permitted by DOT Exception 7280. (Hazardous placards are not required for fuel in vehicle tanks.)
- Fire extinguishers are not removed from motor vehicles.
- Oxygen and acetylene tanks are marked with the prime mover UIC/SUN.
- Trailer mounted equipment containing combustion engines, such as generator sets, are only 50 percent full.
- Five gallon fuel cans, field cans, water heaters, gasoline lanterns, portable generators, blow torches, and similar equipment in which combustibles or fuel other than diesel are used or stored are completely drained and cleaned before shipment. Under a declared national emergency, fuel may be carried in 5-gallon

fuel cans. These cans must remain in built in cradles designed for such purposes (see DOT Exemption 3498).

- The battery box and cover are serviceable. The battery box and cover must be positioned so as to not touch the terminals and to prevent arcing.
- Batteries of non-self-propelled equipment, such as generators, are disconnected and terminal ends are protected from arcing and corrosion.
- Bulk fuel carriers are drained and placarded appropriately. If required, units will purge bulk fuel carriers according to the respective TM.

PLANNING UNIT BASIC LOAD AMMUNITION SHIPMENTS

D-3. Ammunition shipments are normally scheduled through military ammunition ports. To meet deployment requirements, ammunition may be moved through a commercial port.

D-4. If the unit is deployed through a commercial seaport, the USCG must grant a HAZMAT permit. Permits are required for munitions above .60 caliber. They are granted on a case-by-case basis and issued according to [CFR 33](#). The unit must submit HAZMAT data to the ITO to ensure the permit is coordinated with the USCG for pre-positioning. This data will include the following:

- The DODAAC.
- The quantity/unit of ammunition.
- The total weight, in pounds, per box.
- The total NEW.
- The DOT class code/number.
- The QD.
- The storage compatibility of ammunition.

The USCG representative to the port, issues the HAZMAT permit. The permit will specifically identify the amount of unit basic load ammunition per unit, state the name of the commercial port, and grant clearance for a specific amount of ammunition through the port. MTMC has prearranged permits at selected ports for the rapid deployment force basic load requirements.

[RDL](#)[Table of](#)[Document](#)[Download](#)[Homepage](#) [Contents](#) [Information](#) [Instructions](#)

Appendix E

Containerization

Organizational containers are the wave of the future. Containerization of unit equipment and cargo can take on many forms, such as the ISUs, 20-foot MILVANS, and commercial 20- and 40-foot shipping containers. Familiarization with the different types of containers will enhance the selection and loading process.

Considerations when selecting a container should include the characteristics of the container, the cargo to be shipped, available materials handling capabilities, and the available mode for transporting containers. ISUs and QUADCONs are containers developed with unit deployment in mind and should be strongly considered by contingency forces.

SHIPPING CONTAINERS

E-1. The following is a list of available containers units and installations may use for deployments.

EQUIPMENT DEPLOYMENT STORAGE SYSTEM

E-2. The EDSS is a series of containers that consists of a QUADCON and ISUs (ISU-60 and ISU-90). The EDSS has differing transport capabilities from 5,000 to 12,500 pounds depending on the container and method of movement. It is compatible with the FMTV. The system is air transportable, has four liftable points, and is MHE compatible.

Quadruple Container

E-3. The QUADCON measures 82 x 57 x 96 inches (see [Figure E-1](#)). It is a lockable, weatherproof, reusable, prefabricated container with a cargo capacity of 8,000 pounds. The QUADCON has a structural steel welded frame. Its top sides and door panels are made of plywood coated with a plastic laminate. The floor is of high density plywood covered on both sides with sheet steel. It has ISO corner fittings for lifting and restraint and for coupling up to four QUADCONs together. The QUADCON has a base that allows four-way forklift entry. Four QUADCONs coupled together have the same dimensions as a standard 20-foot ISO container. These QUADCONs are compatible with the 20-foot cell guides of a containership.

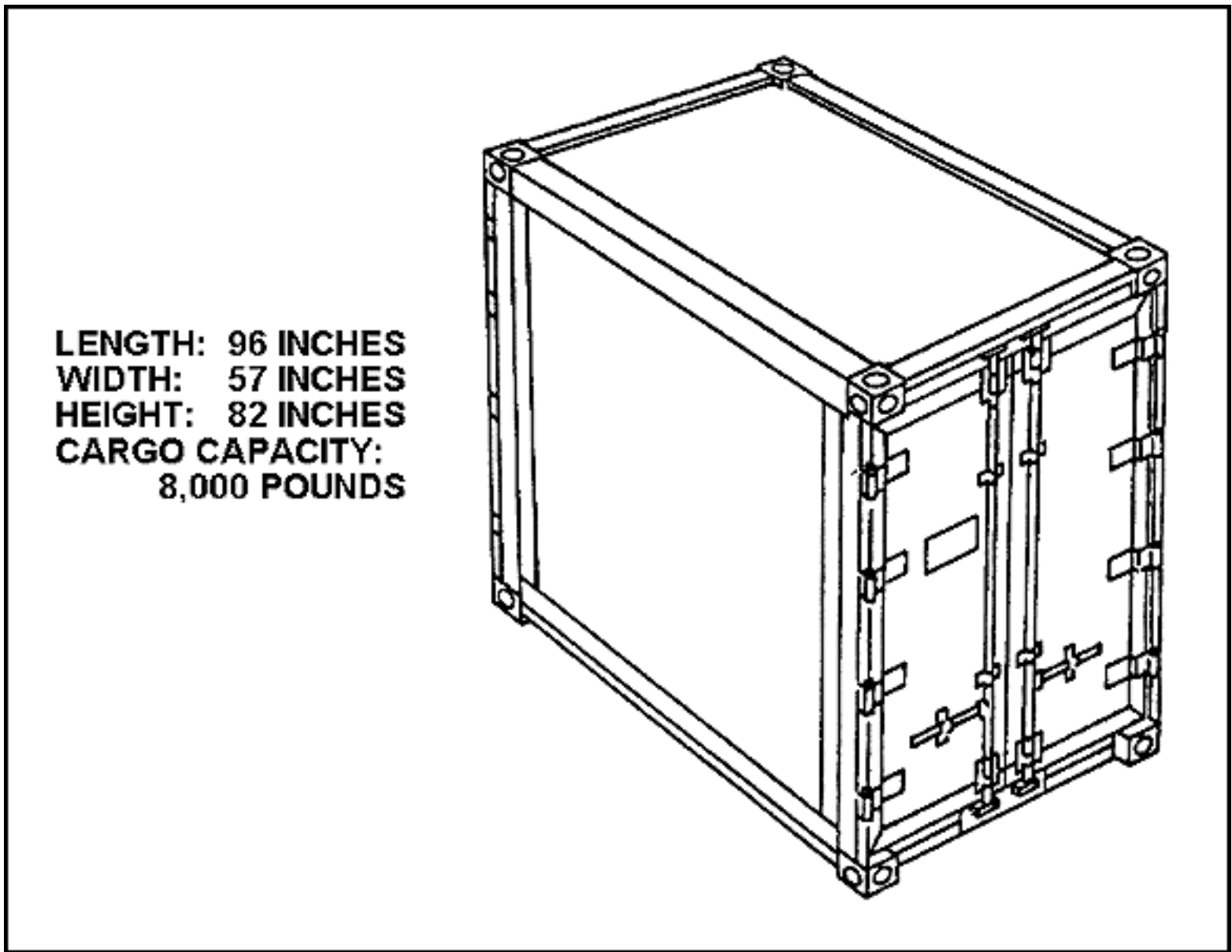

Figure E-1. QUADCON

ISU

E-4. The internal airlift/helicopter slingable container unit (see [Figure E-2](#)) is certified for helicopter internal/external airlift, AMC aircraft, and combat off-load. It is 463L pallet compatible and has a 10,000-pound capacity. The base measures 88 x 108 inches and allows forklift entry. ISUs are available in heights ranging from 60 to 90 inches.

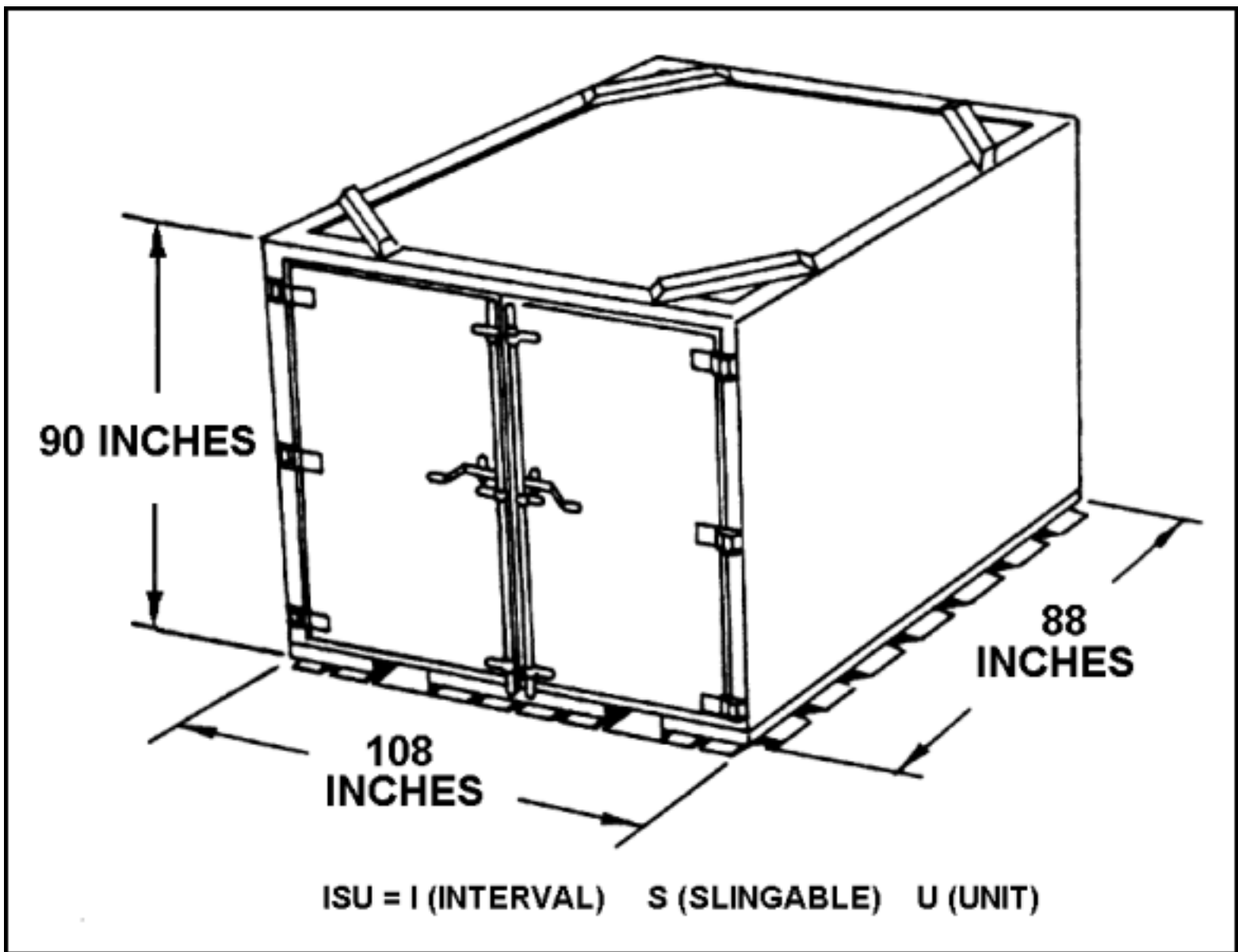

Figure E-2. ISU-90

NOTE: ISU containers should always have shoring to protect the bottom.

MILVAN CONTAINERS

E-5. Deploying units should also consider using 20-foot MILVANs (see [Figure E-3](#)). These containers have a significant weight and cube capacity and fit more efficiently into the transportation system, and will speed the movement of unit equipment through a water terminal. Upon request by the unit, these containers will be obtained through the ITO. The container will be positioned at the location identified by the unit. Any movement of these containers will be coordinated through the ITO or his representative.

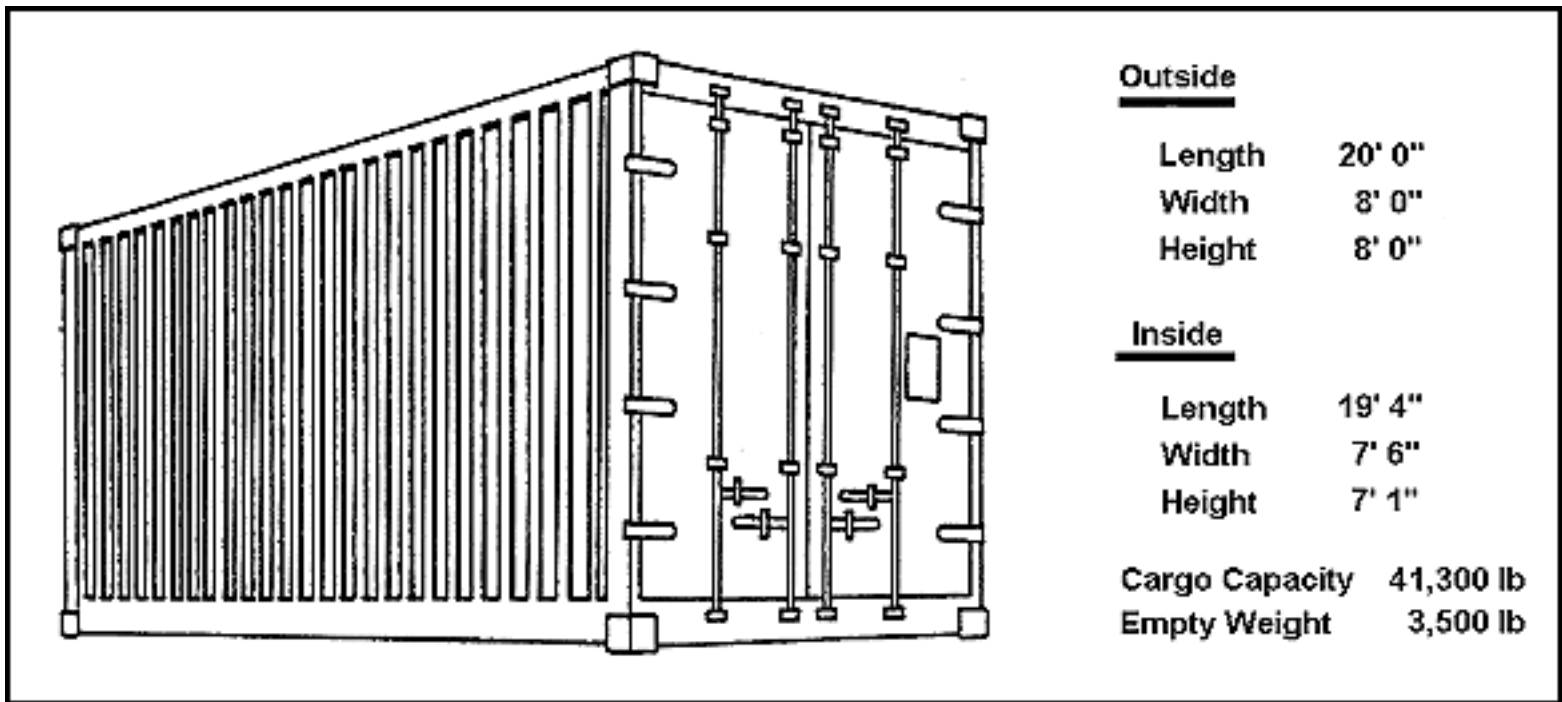

Figure E-3. MILVAN Characteristics

QUALIFICATION OF EQUIPMENT FOR CONTAINERIZATION

E-6. Unit equipment is qualified for containerization based on interior container length, door opening dimensions, and container weight capacities. For blocking and bracing, the usable interior container length is reduced by 6 inches. The decision to use a container will be based on the following:

- Coordination between the unit, the ITO, MTMC, and the gaining command.
- Availability of MHE at destination.
- Means of transporting the container from the SPOD to the unit's destination.
- Guidance from the theater of operations commander on the container's unstuffing location and the container retrograde plan. A theater container return policy must be in place to return containers to the transportation system.

STUFFING SHIPPING CONTAINERS

E-7. Container contents may be subjected to sudden jolts. Therefore, personnel must stuff cargo so that it does not shift inside the container. Boards, packing paper, and banding material are used to keep the load from shifting (for more information, consult [DA Pamphlet 740-1](#)). When stuffing containers, personnel will do the following:

- Distribute the weight of the cargo evenly over the floor of the container.
- Place heavy cargo on the bottom of the container and lighter cargo on top.
- Block and brace the cargo at the bottom, sides, and front of the container, especially near the door.
- Fill in the space between the cargo and the container sides.

- Place any package containing liquid on a double layer of dunnage to reduce damage due to leakage.
- Use block storage to protect bagged cargo from shifting.
- Keep the CB of the cargo as near as possible to the center of the container. If this is not possible, mark the CB on the container and notify the carrier.
- Keep within the load limits of the container. Never overload.
- Close and seal container doors carefully. Put serial numbered seals on the container to detect pilferage and tampering.
- Place one copy of the packing list inside and one outside the door (see [Appendix A](#)).
- Weigh containers before shipment at the origin. Mark weight of container on shipping documents.
- Observe procedures for hazardous cargo (see [Appendix D](#)) and sensitive cargo (see [Appendix F](#)).

[Figures E-4](#) and [E-5](#) show the correct distribution of loads in a container.

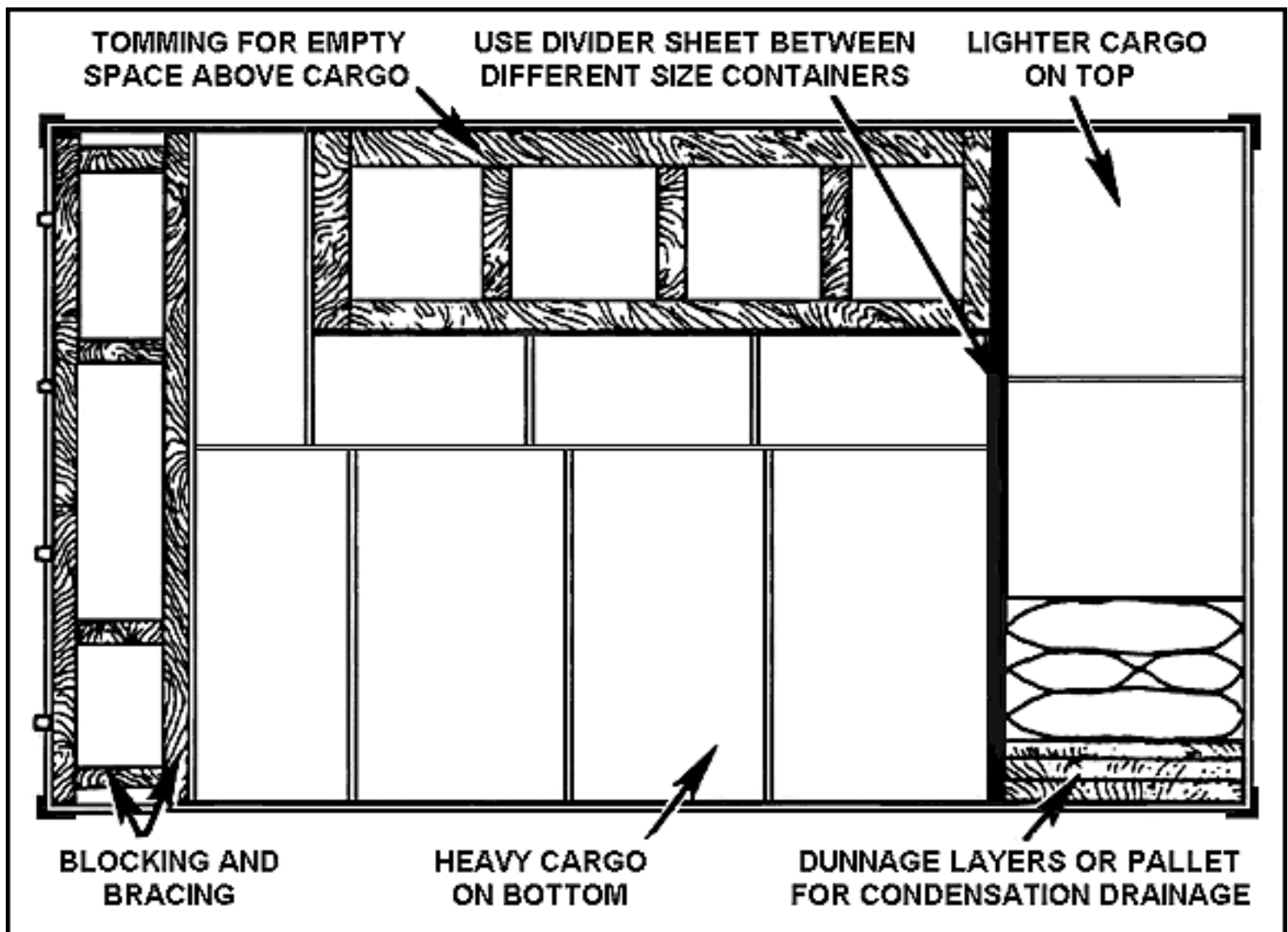
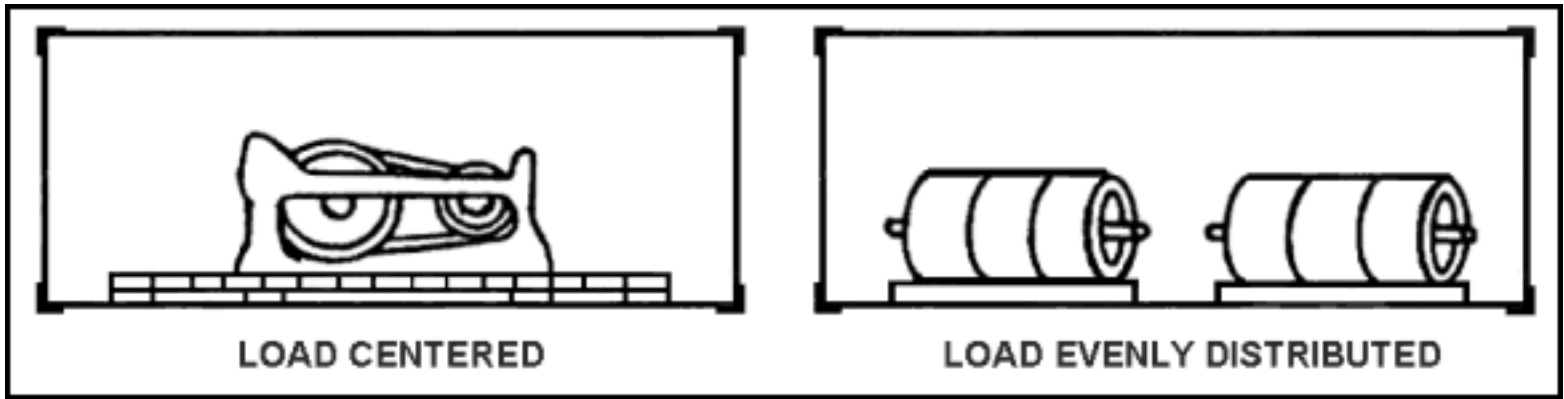

Figure E-4. Distribution of Loads in Containers**Figure E-5. Distribution of Heavy Loads in Containers**

OVERHAUL OR REPAIR OF MILVAN CONTAINERS

E-8. All containers should be inspected for serviceability before stuffing. [Figures E-6](#) through [E-11](#) show the construction and components of typical MILVANs. The following deficiencies should be noted during inspection and constitute damage requiring repairs.

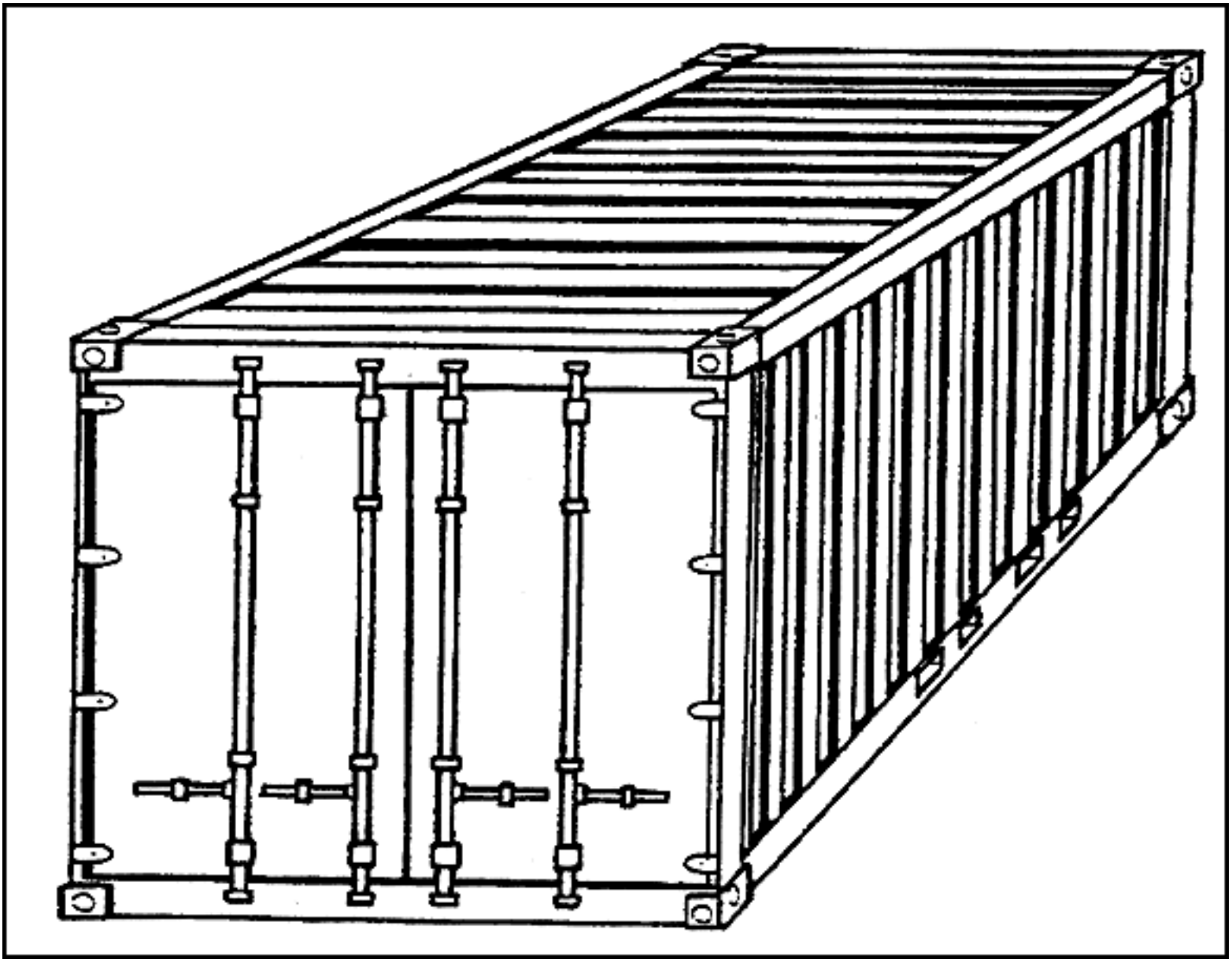

Figure E-6. Main Structural Member

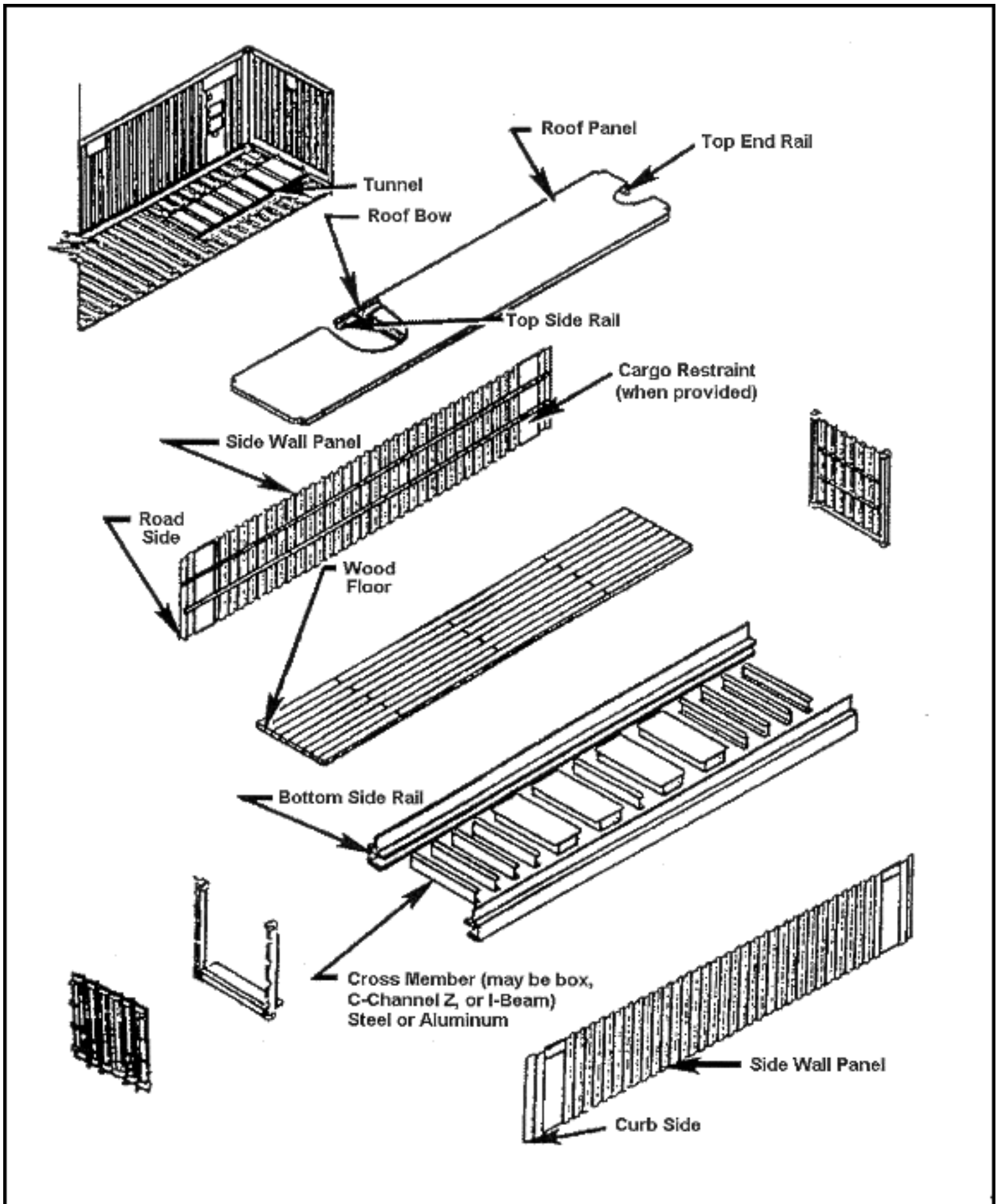

Figure E-7. Exploded View of Typical Steel Container

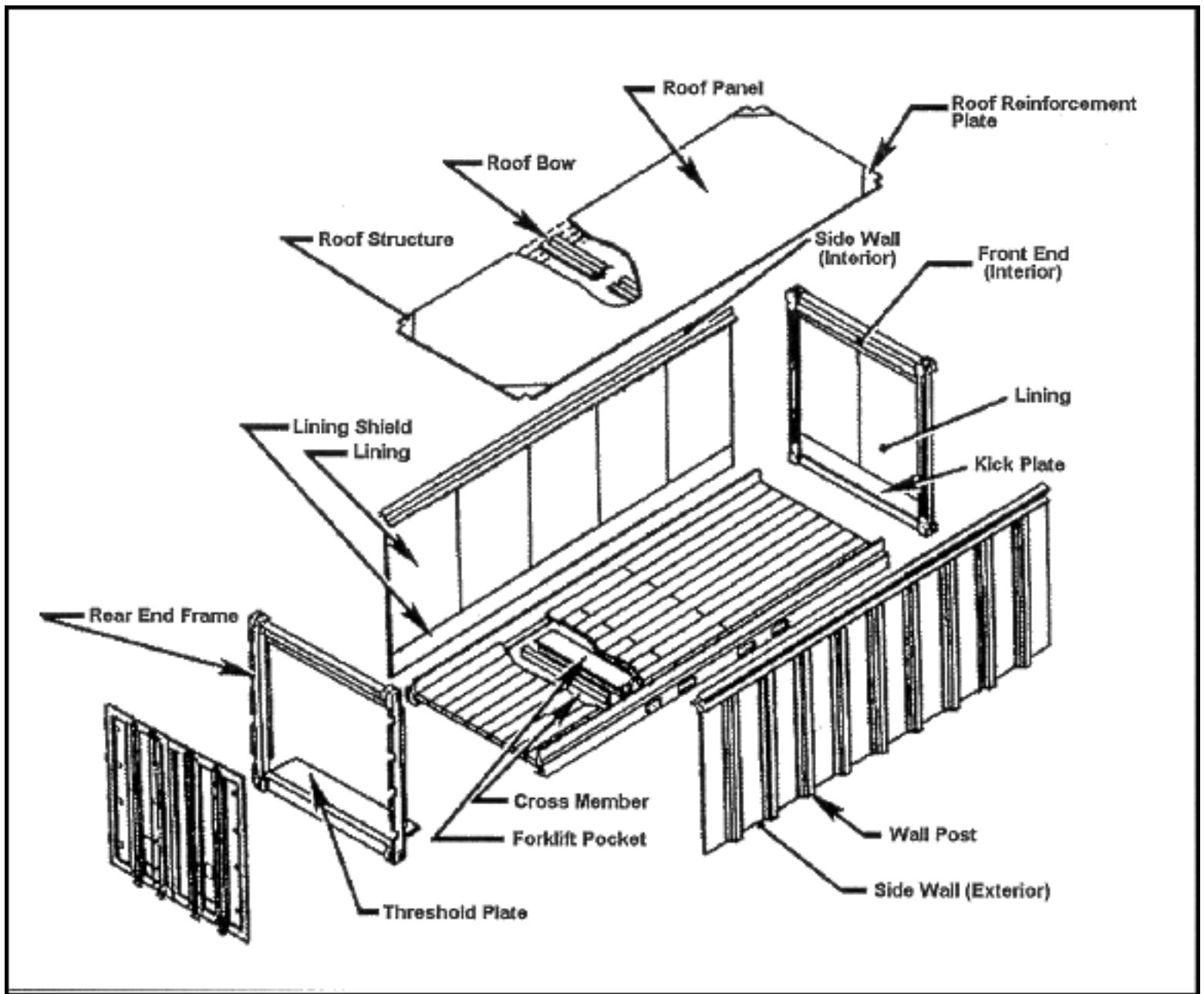

Figure E-8. Exploded View of Typical Aluminum Container

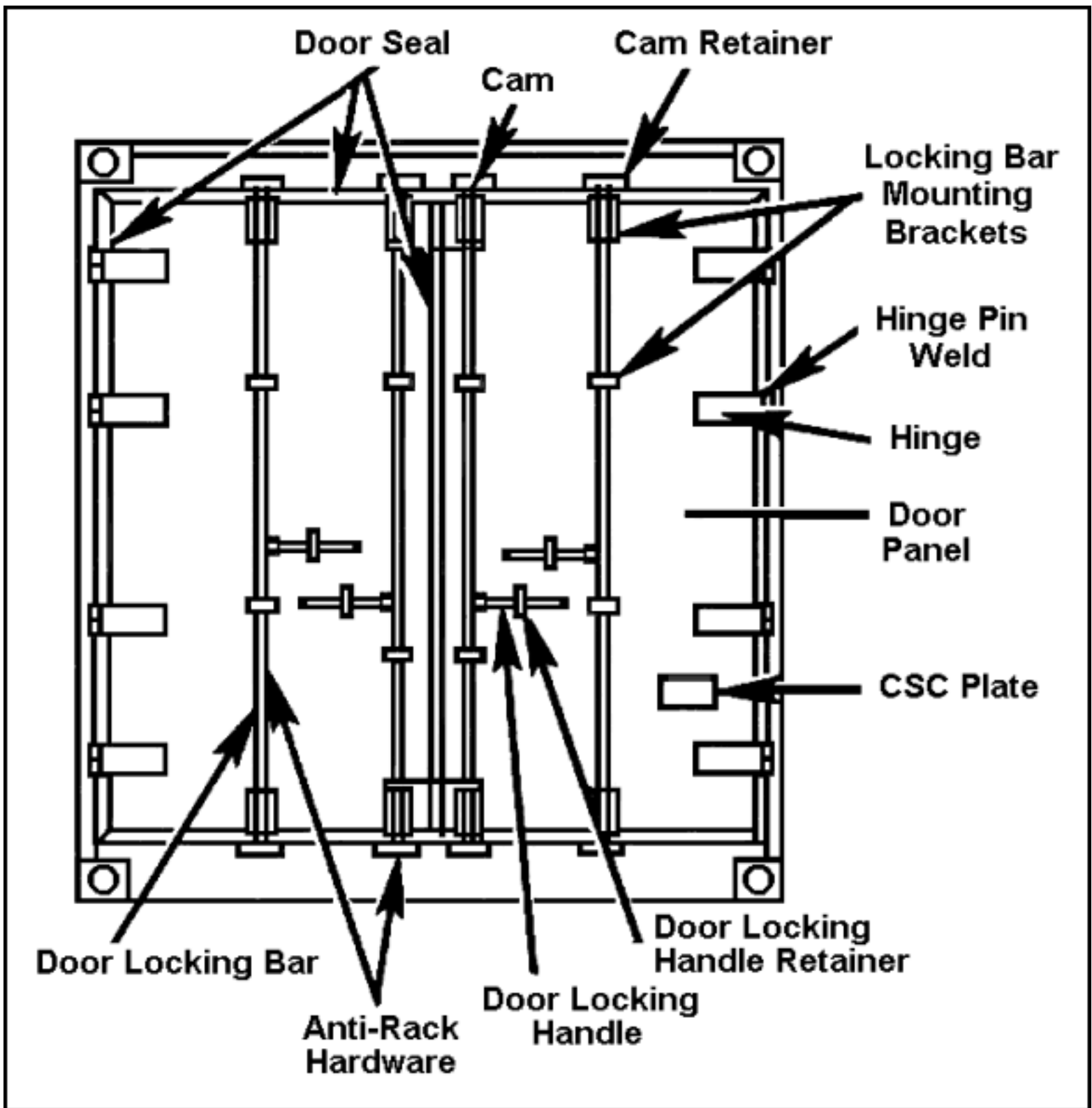

Figure E-9. Typical Rear End and Door Construction

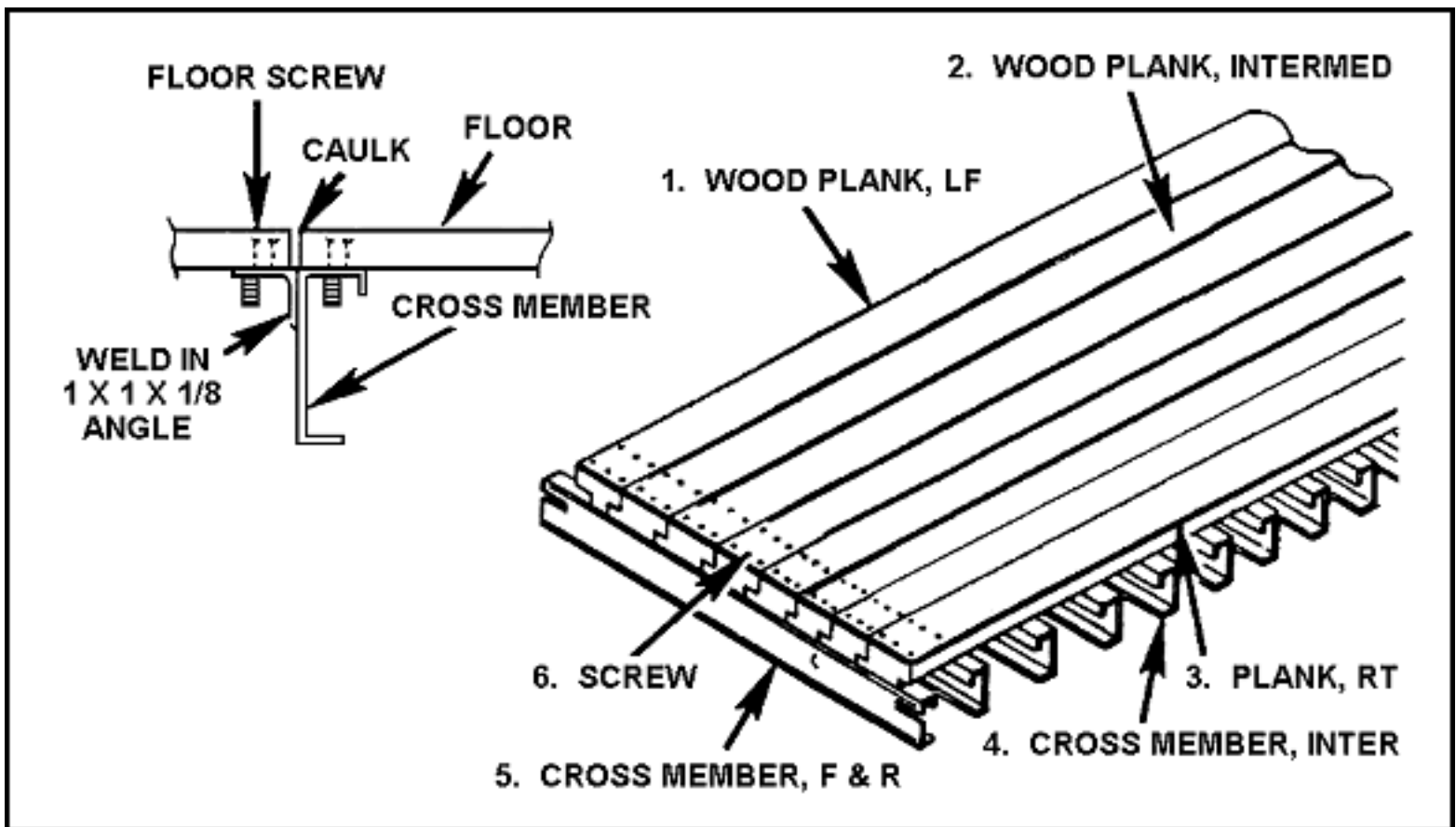
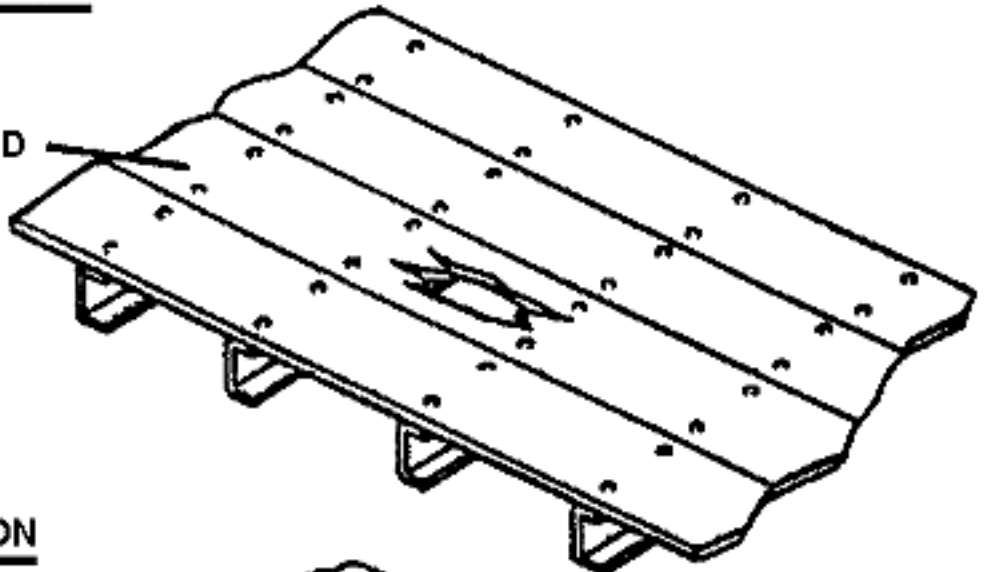

Figure E-10. Wood Floor Structural Components

DAMAGED FLOOR BOARDS

DAMAGED BOARD



CUT DAMAGED SECTION

CAULK

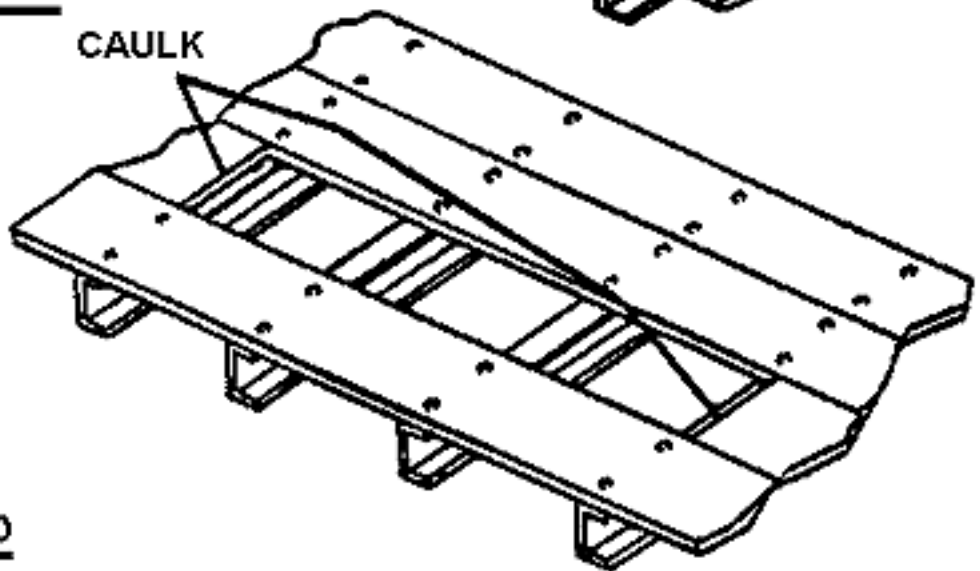

BOARD SPLICE INSTALLED

SELF-TAPPING SCREWS

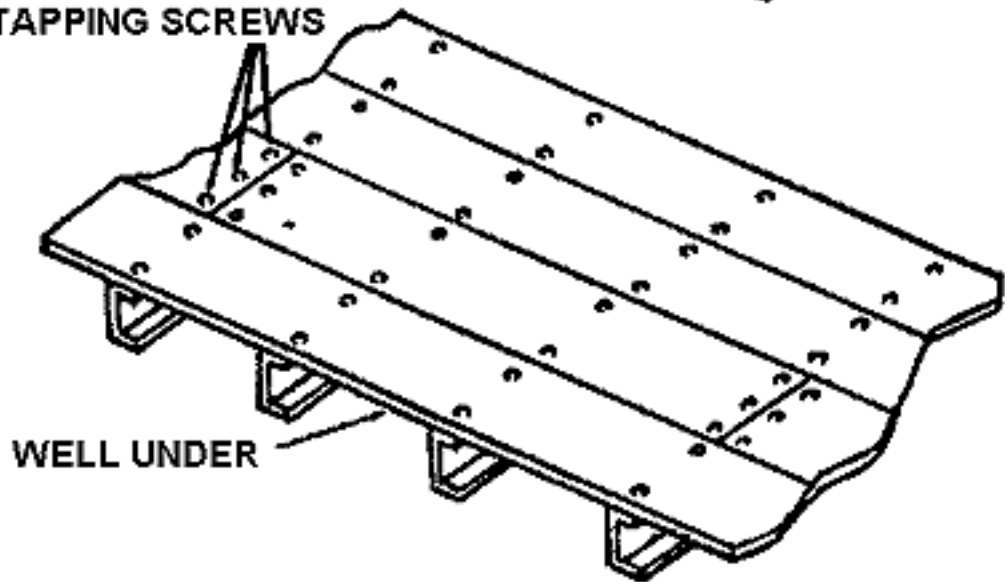

WELL UNDER

Figure E-11. Wood Floor Repair

EXTERIOR

E-9. Check the exterior for the following deficiencies:

- Corrugated sheets should not be dented or torn. Dents cannot exceed 3/4 inch.
- Identification must not be obliterated.
- Welds must not be broken, cracked, or missing. They must be properly made, not primed or painted.
- Top and bottom rails should not be bent, cut, or crushed. Rails must not be bent past the plane of corner fittings. Bends cannot exceed 3/4 inch.
- The door frame must not be cut, broken, or distorted. Hinges must not be broken, torn, or twisted. Doors must not be out of alignment, punctured, or rusted out. Door handles (operating levers) must not be bent or broken.
- Locking bar guides and locking bar tubes must not be bent or twisted.
- Rubber seals must not be cut or torn loose.
- Roof panels should not be punctured or dented or have Stage IV corrosion. Dents may not exceed 3/4 inch.

NOTE: Stage IV corrosion is rust or black or white chemical corrosion with powdering, scaling, severe pitting and holes, and irregular areas of surface material eroded away. Nonacceptable corrosion of nonstructural members can be determined if the corroded metal can be punctured by striking the area lightly with a welder's hammer.

UNDERSIDE

E-10. Check the underside for the following deficiencies:

- Floor cross members should not be bent, cut, crushed, severely rusted, or broken loose from side rails or floor. They should not have cracked or broken welds. Bends may not exceed 3/4 inch.
- Stiffeners should not be bent, cut, crushed, severely rusted, or broken loose from side rails. They should not have cracked, missing, or broken welds. Bends may not exceed 3/4 inch.
- The threshold plate should be firmly attached and free of damage.

INTERIOR

E-11. Check the interior for the following deficiencies:

- Roof bows must not be cut or broken loose from top rails.
- Floor boards must not be splintered, broken, cracked, or rotten.
- The restraint system must not be bent, torn, or detached from side panels.
- Walls and doors (top and bottom) must not leak from metal punctures, cracked welds, or bad seals.

- Corner posts should not be dented, fractured, or torn. Dents may not exceed 3/4 inch. Corner castings (fittings) should not be fractured or distorted.
- The frame must not be out of alignment.
- The inside must not be corroded to the point where its fit, wear, function, or life has been significantly affected.

[RDL](#)[Table of](#)[Document](#)[Download](#)[Homepage](#) [Contents](#) [Information](#) [Instructions](#)

Appendix F

Classified and Protected Sensitive Cargo

Classified cargo is cargo that requires protection in the interest of national security.

Classified cargo shipments have characteristics that require them to be identified, accounted for, secured, segregated, or handled in a special way to ensure their safeguard or integrity.

NOTE: Do not identify security cargo or classified cargo on the outside of the shipping containers.

Sensitive cargo is cargo that could threaten public safety if it is compromised. Sensitive cargo must be properly secured and identified to port personnel so sufficient security can be provided.

CLASSIFIED CARGO SHIPMENTS

F-1. When transporting classified material, enclose it in two sealed containers, such as boxes or heavy wrappings. For detailed instructions when packing classified material, see your unit security manager and [AR 380-5](#). In implementing this requirement, the following considerations apply:

- The classified information inside a packaged item of equipment, the outside shell, or body may be considered as the inner enclosure if it does not reveal classified information.
- If the classified material is an inaccessible internal component of a bulky piece of equipment that is not reasonably packaged, the outside body of the item may be considered a sufficient enclosure if it does not reveal classified information.
- If the classified material is a piece of equipment that is not reasonably packaged and the shell or body is classified, conceal it with a covering that hides all classified features.
- Specialized shipping containers may be used, including lockable cargo transporters, instead of following the above packaging requirements. In such cases, the container may be considered the outer wrapping or cover.
- Packaging material must be strong and durable enough to provide security protection while in transit, to keep items from breaking out of the container, and to help detect any tampering with the container. The wrappings must conceal all classified characteristics.
- Closed and locked vehicles, compartments, or cars will be used for shipments of classified material except when the appropriate authority authorizes another

method.

- When classified material is transported, it will not be stored in any detachable storage compartment, such as automobile trailers, luggage racks, aircraft travel pods, or drop tanks.
- When transporting classified material across international borders, arrangements must be made to ensure that customs, border, or other inspectors (either US or foreign), do not open the material.
- A serial-numbered seal will be placed on doors to containers, vehicles, or compartments that contain classified or protected cargo. The serial number must be entered on the shipment unit packing list.
- The unit authorizing the transport of the classified equipment must notify the ITO and appropriate carrier in advance.

When traveling by motor convoy, escorts must ensure constant surveillance of classified material. Classified material must stay within the escort's personal possession and observation at all times. Larger pieces of secret shipments such as missiles may require outside storage. If so, take special protective measures to include constant and continuous surveillance by at least one or more escorts in the area.

SENSITIVE CARGO SHIPMENTS

F-2. For sensitive cargo, units must adhere to the following:

- Remove crew-served weapons from vehicles. Place them in containers that are sealed and secured with an approved device.
- Be sure packaging material is strong and durable enough to provide security protection while in transit.
- Secure containers, vehicles, or compartments with an appropriate locking device as directed by the installation security officer. Also, place a serial-numbered seal on the door. Enter the serial number on the shipment unit packing list.
- Identify sensitive items in the commodity code on the unit's AUDEL/DEL.
- Do not indicate on the outside of the container, vehicle, or compartment that it contains sensitive items. Identify this fact on the unit's AUDEL/DEL.
- When deploying units, ship sensitive/classified material by rail. Commanders may be required to provide guards/escorts. For shipments other than sensitive/classified material, guards/escorts will be provided at the commander's discretion. See [Appendix G](#) for rail guard duties.

[RDL](#)[Table of](#)[Document](#)[Download](#)[Homepage](#) [Contents](#) [Information](#) [Instructions](#)

Appendix G

Rail Guards and Supercargoes

Cargo guards or escorts maintain surveillance over the military equipment during the journey and notify railroad personnel of any problems. The rail cargo escorts help railroad personnel protect and maintain security of Army equipment loaded aboard trains and protect US Army interests.

A copy of the trip itinerary is given to the cargo escort supervisor. It includes the rail routing by specific rail companies, interchange points, and stop off points within a given rail line. The escorts are given portable radios to maintain communication with escort supervisors and other escorts.

Guards/escorts may ride in the locomotive. This eliminates the need for placing an additional caboose or guard car on the train. Escorts are instructed on locomotive and railroad safety.

NOTE: The deploying unit commander makes the final determination based on security requirements and coordinates with the ITO and authorized railroad representatives on guard/escort matters.

Guards/escorts are armed at the installation commander's discretion. When armed guards are used, all participating railroads must be notified. All armed guards must be familiar with the rules of engagement and trained in the use of force.

SECTION I - Rail Guards

SAFETY PROCEDURES

G-1. Rail loading and unloading operations must be conducted carefully to prevent personnel injuries and loss of equipment. The following items must be strictly adhered to by everyone in the operation, particularly the OIC/NCOIC.

SAFETY GUIDELINES AND BRIEFING ITEMS

G-2. It is strongly recommended that the following guidelines and items be used as the basis for the operation's safety briefing.

- No loading will begin until all participants have received a full safety briefing from the OIC/NCOIC (or designee).
- Blue flag track.

- Uniform hand signals must be established for use by Car Guides, ensuring that all drivers are fully aware of those signals. The signals must be a major portion of the safety briefing.
- All loading personnel **MUST** wear leather gloves (not cloth gloves or military black glove "liners" or inserts) and will wear hard hats or helmets (not merely helmet liners). Eye protection (goggles) is highly recommended, but is optional depending on availability. Goggles are always required when driving nails into blocking material.
- Personnel will not jump onto or from railcars. Use the steps provided or walk on/off the railcar using an adjacent railcar or loading dock.
- Do not crawl under any railcar.
- Do not step between railcars.
- Do not step onto a coupler, the coupler assembly, or its hoses.
- Do not step or walk on the rails. They become very slippery if any lubricant has been spilled upon them or when wet.
- Do not stand or walk between a moving vehicle and a parked vehicle on the railcars or in the loading area. Ensure the vehicles engines are off and hand brakes set before you begin securing vehicles to railcars.
- Chock both ends of two wheels (at least one on each side) of the first railcar, then at least one wheel per side on every third railcar thereafter. You may use 2 X 2's or 2 X 4's as chocking material.
- No vehicle will be moved onto or while on a railcar without a Car Guide to the front of that vehicle and two Side Guides (one on the ground on each side of the vehicle being moved). Only the Car Guide may give instructions to the vehicle driver, but the Side Guides will keep the Car Guide advised of the location of the vehicle in relation to the edges of the railcar.
- The Car Guide should stay one railcar ahead of the vehicle being guided. That will require that the Car Guide direct the vehicle to the spanners leading onto the railcar on which he is standing, stop the vehicle, turn around and walk the full length of that railcar and onto the next in line, then turn around and guide the vehicle across the spanners onto the railcar which he just left. When the Car Guide is guiding a vehicle onto a railcar where there is already a parked vehicle, he will assume a secure and observable position on or beside the parked vehicle so that he cannot be pinned between the moving and parked vehicles.
- No personnel, especially Car Guides, shall walk backwards on any railcar. Preferably no personnel shall walk backwards anywhere in the area of the loading due to the likelihood of obstacles or debris on the ground in that area.
- Do not wear rings while rail loading. Also, the wearing of watches with military or other fabric around-the-wrist bands should not be allowed, as the band may become hooked on a moving object, dragging the wearer by the tough fabric.

- Do not attempt to pull nails from a railcar deck without proper equipment. Large nails should only be removed by using a long prybar (such as a "gooseneck" wrecking bar) with a nail "notch" due to the size and length of the nails used in the railcars.
- When using a long prybar around other loading personnel, either pad the end of the prybar or cover its end with one hand to avoid striking or jabbing other personnel with the prybar.
- On wooden deck flatcars, splintered wood can be very hazardous, and should be avoided (or removed, if possible).
- There will be NO SMOKING in the loading area.
- The OIC/NCOIC should ensure that water and first aid kits are readily available at the site. If possible, medical personnel and a medical evacuation vehicle should be on hand.
- If loading is to be conducted during hours of darkness, adequate lighting (not unit equipment that is to be loaded) should be made available. Lighting should be located at deck-level, to avoid placing the work areas under the vehicles in shadow.
- Car Guides must ensure that vehicles are not driven onto spanners until it is verified that the spanners are properly aligned and set.
- If at all possible, do not back any vehicles onto or while upon the railcars.
- If the unit will be using bi-level or tri-level cars, load team personnel must be very careful when moving around the ends of the cars, since they are open and a soldier could easily fall to the ground or onto the coupling from them.
- All rail load personnel must be alert for any unsafe actions or situations, and all personnel have the responsibility and ability to immediately halt all operations if an unsafe situation or action is observed. The OIC/NCOIC will then ensure that the unsafe situation or action is corrected prior to the resumption of operations.
- Use only authorized and approved tools. Use them only for the purpose for which they were designed.

SPECIFIC DUTIES

G-3. Cargo guards/escorts will become familiar with the train when they report for duty. Escorts conduct a cargo check one to two hours before the train's departure with the railroad representative.

G-4. The cargo escort supervisor ensures that the guard car has enough rations to allow for any delays that might occur. The escort supervisor checks to ensure that supplies are adequate for the trip.

G-5. Cargo guards/escorts make cargo checks whenever the train stops for 30 minutes or more. The train conductor determines the estimated time for stops. During the cargo check, cargo escorts inspect the equipment to determine the following:

- If cargo has shifted or tie-down devices have loosened.
- If cargo has been tampered with since the last check; for example, seals missing or locks and doors unsecured.
- If cargo is missing.
- If cargo has been damaged.

G-6. During stops en route, guards are staggered along both sides of the train. Suspicious incidents or the presence of unauthorized persons are reported to the guard in charge and to railroad personnel. Guards use the buddy system to investigate incidents or to approach a suspect.

G-7. If a railcar must be removed from the train and left on a side track for maintenance, the following procedures apply:

- If the car has no sensitive or security cargo on it, no cargo escort is left with the car.
- If the car contains sensitive or classified cargo, the car must be guarded constantly.

INCIDENT REPORT

G-8. The guard or escort that discovers the problem must complete an incident report for each occurrence and give it to the person in charge of the detail. Immediately upon arrival at the destination, the person in charge gives the reports to the destination transportation officer, who sends them to the commander of the appropriate MTMC area command. The report shows the following:

- What happened.
- Where the incident occurred.
- When the incident occurred (date and time).
- Which railcars were involved.
- Who was involved in the incident.
- Who was notified of the incident.

The guard or escort must still report immediately by telephone to the MTMC area command all major incidents that could delay a shipment en route.

SECTION II - Supercargoes

G-9. Supercargoes are teams of soldiers who accompany, supervise, guard, and maintain unit equipment aboard the ship. An essential part of their job is to monitor and correct equipment lashings and tie-downs during movement. They also provide key control, note items that cannot be repaired en route, and brief the port commander at the SPOD on vehicle conditions and any peculiar aspects of the cargo.

G-10. Supercargoes are the deploying unit commander's on-board representatives

during the movement of unit equipment on a ship. While the exact composition of the supercargo team depends on several factors, it generally consists of an OIC/NCOIC, classified/sensitive cargo escorts, and selected maintenance personnel for the type and quantity of equipment being shipped.

G-11. The composition of the supercargo team depends on the number of passenger berths available, the amount and mix of vehicles and equipment deployed, the length of voyage, and the number of units deploying equipment on a ship. Working and living conditions are austere, but with proper planning, the travel should not result in hardship.

G-12. Mechanics are required for wheeled and tracked vehicles, aircraft, and communications equipment. Supercargo personnel must be experienced and licensed on all types of vehicles being shipped. Though it may not be practical for each supercargo to be licensed on each vehicle deployed, the team must consist of qualified drivers for each vehicle on the ship.

G-13. Supercargoes are critical to shipping and maintaining the operational readiness of equipment to enhance the unit's effectiveness on arrival in the overseas theater. The supercargo team performs the following:

- Makes periodic checks of unit cargo aboard the vessel.
- Maintains key control of vehicles.
- Makes repairs as practicable.
- Documents those items that could affect discharge operations.
- Provides maintenance support and liaison during cargo reception at the SPOE and during ship loading and discharge operations and SPOD clearance operations.

G-14. The following rules help supercargoes do their job safely and effectively:

Rule 1: The captain is the ultimate authority on the ship. His word is absolute law, and every individual must obey him.

Rule 2: The first mate is the captain's right-hand man. If you are having a problem, go to the first mate. Before the ship sails, the first mate should brief supercargo officers and NCOs on the following:

- General safety requirements.
- Fire and lifeboat drill and stations.
- Life preserver requirements.
- Restricted deck areas.
- Situations (fire or ship taking water) that require immediate notification of the ship's crew and what to do in each case.
- The ship's layout including emergency escape hatches.
- Whistle signals and their meanings, such as collision warning whistle and abandon ship whistle.

- The chain of command.
- Call signs for ship's officers (for use when supercargoes are issued ship's hand-held radios).

RESPONSIBILITIES

G-15. The following is a list of responsibilities for supercargoes and major commands.

MILITARY SEALIFT COMMAND

G-16. The commander, MSC must do the following:

- Provides MTMC with berthing availability for supercargoes and indicates maximum number of berths per ship.
- Assumes operational control of supercargoes when they sign in aboard ship.
- Orients and briefs supercargoes on the ship's layout and facilities, ship procedure, protocol, and contacts during the voyage.
- Provides the vessel captain or first mate with a copy of the SOP.

MILITARY TRAFFIC MANAGEMENT COMMAND

G-17. The commander, MTMC will do the following:

- Coordinates with MSC for the number of supercargoes required on the planned report date.
- Provides a copy of the SOP to the supercargo OIC/NCOIC.
- Provides cargo operation orientation briefing to appropriate port authorities.
- Assumes operational control of supercargoes until they report onboard ship. (Supercargoes are released upon completion of port clearance operations at the SPOD to the deploying unit.)

INSTALLATIONS AND UNITS

G-18. Commanders of installations and units will do the following:

- Select and brief individuals. Supercargoes must be familiar with the overall concept of deployment and must be able to brief the MTMC terminal commander at the SPOD on the status of equipment.
- Appoint individuals on orders (using DA Form 1610-R) as supercargoes.
- Dispatch a message to the MACOM, MTMC, and MSC identifying selected individuals by name, rank, service number, and unit.

G-19. The supercargo OIC/NCOIC will do the following:

- Reports to the port commander immediately upon arrival at the SPOE.
- Finalizes berthing, messing, and personal hygiene arrangements of the

supercargoes with the vessel captain or first mate. Problems are brought to the attention of the MTMC port commander or MSC representative for resolution.

- Is responsible for discipline, such as counseling, remedial training, and uniform, and administration of Army personnel. (The parent unit keeps authority to impose nonjudicial punishment.)
- Instructs supercargoes on their responsibility to comply with the vessel regulations.
- Coordinates supercargo routine and emergency duty stations with the vessel captain or first mate.
- Establishes a duty roster for supercargoes for continued coverage of the cargo operation and full responsiveness to the MTMC port commander or vessel first mate.
- Gets permission to send personnel into the cargo areas to perform maintenance or other work from the vessel captain or first mate.
- Maintains 24-hour watch, surveillance, or contact with the vessel's first mate.
- Provides key control measures.
- Uses [DA Form 1594](#) to record or log daily supercargo activities.
- Identifies any special load/discharge requirements and specifies vehicles with problems, such as fluid leaks or flat tires.
- Provides status reports to the vessel's first mate on vehicle and equipment checks.
- Attends port operations meetings at the SPOE and SPOD to be familiar with operations and vehicle status.
- Reviews the SOP with the vessel's captain or first mate. It is important that they discuss and clearly understand the role/relationship of supercargoes aboard ship.
- Provides the first mate a manifest of the supercargoes (full name, rank, social security number, unit, place of birth, and citizenship) and leaves a copy with the port commander.
- Checks with the first mate before the ship sails to verify if additional information is required.
- Briefs team members on expected weather conditions for the next 24 hours so they can dress appropriately.
- Establishes a buddy system to check holds and makes sure each team entering a hold has a radio and checks into and out of the hold on the supercargo radio net. Records reported discrepancies for the next day's briefing and plans proper corrective actions. Supercargo team members do not go into holds alone without a radio. If the member falls and is injured, he will not be missed until the next team accountability time.
- Checks the aircraft and vehicle lashings to make sure they are properly tightened but not overtightened.

- Drills the supercargo team on lifeboat and abandon ship procedures.
- Checks all the holds for running vehicles.
- Reports suspected damage or pilferage to the MTMC port commander or designated representative.
- Provides key control of vehicles and helps port operations personnel maintain keys.
- Periodically starts vehicles near loading/discharging ramps to prevent hindering vessel discharge.

The supercargo OIC/NCOIC pays special attention to vehicles loaded on ramps and on the deck. Not only are the walking areas in these locations treacherous, but also loose lashings and missing chocks could result in losing a vehicle over the side or having the vehicle break loose on the ramp and hit the ship's watertight doors at the bottom of the ramps. He also gets team members to stow all supercargo gear as soon as possible after consultation with the first mate.

COMMAND AND CONTROL

G-20. Upon arrival at the SPOE, supercargoes are under the operational control of the port commander. While onboard a ship, the supercargoes are under the command and control of the vessel's captain or first mate. Upon arrival at the SPOD, supercargoes are under the operational control of the port commander. Supercargoes are normally released to the unit on completion of port clearance operations.

DOCUMENTATION

G-21. Supercargoes may use the following during vessel operations.

DUTY LOG

G-22. Supercargoes should use [DA Form 1594](#) to record their daily activities. Mandatory entries include checks of equipment, key control actions, and damage reports. If the situation is severe, request the information be transmitted to the SPOD from the ship while en route.

DEFICIENCIES

G-23. Use [DA Form 2404](#) to note deficiencies and any corrective actions on vehicles and equipment. Complete the form with three copies. Attach one copy to the original [DA Form 1594](#) and give it to the port commander. Attach another copy to the [DA Form 1594](#) that is given to the unit commander of the supercargoes. One copy is attached to the piece of equipment.

EQUIPMENT

G-24. In addition to personal items required to support the supercargo, sufficient maintenance-related items must accompany the supercargo. This includes but is not limited to the following:

- Tool set, general mechanic's (one per mechanic).
- Jumper slave cable (one set per deck).
- One battery charger.
- Limited Class III and IX items required for repair en route, such as batteries, headlights, reflectors, oil, lubricants, and deicer.

[RDL](#)[Table of](#)[Document](#)[Download](#)[Homepage](#) [Contents](#) [Information](#) [Instructions](#)

Glossary

AACG	arrival airfield control group
AAI	air-to-air interface
AALPS	Automated Airload Planning System
AAR	Association of American Railroads; after-action report
AC	active component
ACL	allowable cabin load
A/DACG	arrival/departure airfield control group
ADANS	Air Deployment Analysis System
Aerial Port Documentation and Management System (ADAM III)	The cargo portion of the Consolidated Aerial Port Subsystem.
aerial port of debarkation	A station which serves as an authorized port to process and clear aircraft (scheduled, tactical, and ferried) and traffic for entrance to the country in which located. See port of debarkation.
aerial port of embarkation	A station which serves as an authorized port to process and clear aircraft (scheduled, tactical, and ferried) and traffic for departure from the country in which located.
AFJMAN	Air Force joint manual
AFR	Air Force regulation
AG	Adjutant General
AGL	above ground level
airlift clearance authority	A service activity which controls the movement of cargo (including personal property) into the airlift system.

Airlift Deployment and Analysis System

An AMC-unique automation system which provides interactive deployment scheduling, scheduling for deliberate planning, wartime and contingency planning, exercise deployment/redeployment planning, peacetime scheduling, and airlift efficiency analysis.

air line of communication

Army resupply cargo.

alert condition

Includes five DEFCONs and two EMERGCONs.

allowable cabin load

The maximum payload which can be carried on a mission. It may be limited by the maximum takeoff gross weight, maximum landing gross weight, or by the maximum zero fuel weight. Maximum through load is limited to that which can be carried on the critical leg of a route segment.

ALM

TC-ACCIS Airload Module

AMC

Air Mobility Command

AMCP

Air Mobility Command Pamphlet

AMCS

Air Mobility Control Squadron

AMOPES

Army Mobilization and Operations Planning Execution System

AO

area of operation

AOC

airlift operations center

AOR

area of responsibility

APFT

Army physical fitness test

APOD

aerial port of debarkation

APOE

aerial port of embarkation

AR

Army regulation

ARCENT

United States Army Central

Army Mobilization and Operations Planning Execution System

AMOPES, established by AR 500-5, is a single source document for policy, guidance, and planning assumptions on strategic employment, mobilization of military and civilian manpower, deployment of Army forces, and demobilization. As the Army supplement to JOPEs, it ensures that the Army will plan and execute actions to provide and expand Army forces and resources to meet requirements of unified and specified commands under premobilization and postmobilization conditions. AMOPES is updated biannually.

ARNG Army National Guard

arrival airfield control group User-provided group to perform aerial port functions during unit deployment.

arrival/departure airfield control group A user- provided group to perform aerial port functions during unit deployment, employment, and redeployment.

ASCC Army Service Component Command

ASG area support group

ASL authorized stockage list

ASPUR Automated System for Processing Unit Requirements

AT all terrain

ATC Army training center

ATMCT air terminal movement control team

ATO air tasking order

ATTN attention

AUEL automated unit equipment list

AUOCAP Automation of the Casualty Analysis Process

AUTOREP Automation of the Theater Shelf Requisitioning Process

battalion An Army unit consisting of approximately 700 to 1,000 soldiers.

BBPCT blocking, bracing, packaging, crating, and tie-down

BBTM blocking, bracing, tie-down materials

bde brigade

beachhead	A designated area on a hostile shore which, when seized and held, ensures the continuous landing of troops and materiel and provides maneuver space requisite for subsequent projected operations ashore. It is the physical objective of an amphibious operation.
bn	battalion
brigade	An Army unit consisting of approximately three to five battalions or 2,500 to 3,000 soldiers.
btry	battery
bulk cargo	Cargo that is within the usable dimensions of a 463L pallet (84 inches by 104 inches) and within the height requirements established by the cargo envelope of the particular model of aircraft. This cargo is air transportable on C-5, C-141, and C-130 aircraft.
C2SRS	Combat and Control Strength Reporting System
C4	command and control, communications and computer
CAD	computer-aided design
CAEMS	Computer Aided Embarkation Management System
CALM	Computer Aided Loading and Manifesting
CAP	crisis action planning
CB	center of balance
CCN	convoy control number
CDC	CONUS demobilization center
CFR	code of federal regulation
CHE	container-handling equipment
CI	coordinating installation
CINC	commander in chief
CJCS	Chairman of the Joint Chiefs of Staff
COCOM	combatant command

combatant command	The authority of a combatant commander to perform command functions over assigned forces involving organizing and employing commands and forces, assigning tasks, designating objectives, and authoritatively directing all aspects of military operations, joint training, and logistics necessary to accomplish the assigned mission. COCOM provides full authority to organize and employ commands and forces as the CINC considers necessary to accomplish assigned missions. COCOM is not transferrable.
COMPASS	Computerized Movement Planning and Status System
COMPES	Contingency Operation/Mobility Planning and Execution System
COMPO	component code
component code	A one position code used to identify Army status of each organization. (COMPO 1- Active Army, COMPO 2 - ARNG, and COMPO 3 - USAR).
Computer Aided Embarkation Management System	CAEMS is an interactive database/graphics tool for producing amphibious, MPF and MSC ship load plans and associated reports. CAEMS employs linked CAD and database systems to recognize ship and cargo characteristics, to conduct cargo onload and offload flowpath analysis, to allocate cargoes to stowage spaces, and to ensure stowage compatibility requirements are met. CAEMS also provides input to TSS calculations and produces accurate as-loaded ship load plans and reports. During the planning and execution phases of an operation, CAEMS updates MDSS II.
computer aided load manifesting	CALM is an automated Air Force-designed and -maintained system for producing AMC-approved aircraft load plans and reports. CALM automatically computes the optimal configuration of cabin loads of C-130, C-141, C-5, and KC-10 aircraft by aggregating weights, volume, center of balance, and cargo compatibility.
Computerized Movement Planning and Status System	A FORSCOM-unique system designed to support unit movement planning and requirements for active and reserve component units. This system provides the AUEL, which reflects the go-to-war equipment profile of deploying units, for UMD.
COMSEC	communications security
CONEX	container express
CONPLAN	concept operation plan
Container Delivery System	Gravity extracted airdrop method.

CONUS	continental United States
CONUSA	the numbered armies in the continental United States
COR	contracting officer representative
CP	checkpoint
CRAF	Civil Reserve Air Fleet
CRC	CONUS replacement center
CS	combat support
CSA	Chief of Staff, US Army
CSAF	Chief of Staff, United States Air Force
CSS	combat service support
CTA	common table of allowances
CTO	corps transportation officer
cyl	cylinder
DA	Department of the Army
D/AACG	departure/arrival airfield control group
DACG	departure airfield control group
DAMMS-R	Department of the Army Movement Management System-Redesign
DASPS-E	Department of the Army Standard Port System-Enhanced
DCSLOG	Deputy Chief of Staff for Logistics
DCSOPS	Deputy Chief of Staff for Operations and Plans
DD	Department of Defense
DDD	Direct Distance Dialing
DDN	Defense Data Network
DEFCON	defense readiness condition
DEL	deployment equipment list

deployment control unit	Nondeployable FORSCOM management asset available to MTMC to assist in surface movement of equipment.
DMS	demobilization station
DNA	deoxyribo nucleic acid
DOD	Department of Defense
DODAAC	DOD activity address code
DODX	government-owned railcar
DOL	Director of Logistics
DOT	Department of Transportation
DPW	Director of Public Works
DS	direct support
DSB	deployment support brigade
DSN	Defense Sattelite Network
DTO	division transportation officer
ea	each
EDRE	emergency deployment readiness exercise
EDSS	Equipment Deployment Storage System
EMERGCON	emergency condition
equipment concentration site	An equipment storage area where USAR equipment not necessary for home station training can be located for annual training, multiple unit training assembly, or mobilization.
EUCOM	European command
F	Fahrenheit
FEBA	forward edge of the battlefield
FLOWCAP	Flow Computer Assisted Program
FM	field manual
FMTV	family of medium tactical vehicles

force/activity designator	Identifies urgency of movement within the supply/transportation community.
FORMDEPS	FORSCOM Mobilization and Deployment Planning System
FORSCOM	United States Army Forces Command
forward edge of the battle area	A line/zone dividing friendly and enemy forces.
forward line of own troops	Line of troops nearest enemy held/controlled territory.
forward operating base	A self-sustaining base in close proximity to FEBA.
G3	Assistant Chief of Staff, G3 (Operations and Plans)
GBL	government bill of lading
GDSS	Global Decision Support System
global transportation network	An integrated network of command, control, communication, and computer systems as well as related procedures, policy, and personnel in support of USTRANSCOM's global transportation management and operations.
Government Accounting Office	Accomplishes audits at all management/operational levels to ensure efficient expenditure of existing resources.
GTN	global transportation network
HAZMAT	hazardous material
HHC	headquarters and headquarters company
HHD	headquarters and headquarters detachment
HN	host nation
HNS	host nation support
home station	The permanent location of active, ARNG, and USAR units (post, camp, station, armory, and center).
HQ	headquarters
HQDA	Headquarters, Department of the Army
HS	home station

ICODES	Improved Computerized Deployment System
ICUMO	intermediate command unit movement officer
ID	identification
IMDG	International Maritime Dangerous Goods
IRR	Individual Ready Reserve
ISA	Interservice Support Agreement
ISB	intermediate support base
ISO	International Standardization Organization
ISU	internal slingable unit
ITO	installation transportation office(r)
ITV	in-transit visibility
J3	Operations Directorate
JAG	judge advocate general
JCS	Joint Chiefs of Staff
JFC	joint force commander
JMC	Joint Movements Center
joint airborne/air transportability training	Air Force-funded, AMC-managed program to exercise tactical airlift maneuvers while satisfying user combat training.
JOPEs	Joint Operations Planning and Execution System
JPEC	Joint Planning and Execution Community
JSDTC	Joint Strategic Deployment Training Center
JSPS	Joint Strategic Planning System
JTF	joint task force

Landing Force Asset Distribution System	LFADS is a supply and equipment management system to support the MAGTF commander and sustain the MAGTF during deployment. LFADS produces materiel requisitions that are passed to sources of supply. On-hand assets and replenishment status can be tracked at various echelons, giving an accurate logistics posture as an operation evolves.
LDC	land defense of CONUS
LFADS	Landing Force Asset Distribution Center
LIN	line item number
LOC	line of communication
LOGMARS	Logistical Application of Marking and Reading Symbology
LOTS	logistics over-the-shore
MACOM	major Army command
MAGTF	Marine Air-Ground Task Force
MAGTF Deployment Support System II	MDSS II enables commanders at various echelons of a MAGTF to build and maintain a database that contains force and equipment data reflecting how the AGTF is configured for deployment. This data can be maintained during normal day-to-dayarrison activities and updated during plan development and execution. Extracted MDSS II data rovides the JCS and national command authority with an accurate picture of the MAGTF omposition including the lift requirement by passing the information through MAGTF II.
MAISRC	Major Army Information System Review Counsel
materials-handling equipment	Equipment specifically designed for handling cargo in storage and on/offload operations in the transportation system.
MC	movement control
MCA	movement control agency
MCC	movement control center
MCI	military customs inspector
MCT	movement control team
MDDS II	MAGTF Deployment Support System II
MDRD	mobilization, deployment, redeployment, demobilization

medical evacuation	Movement of casualties from combat zones to rear area hospitals and from recovery bases to the CONUS.
METL	mission-essential task list
METT-T	mission, enemy, terrain, terrain, and time available
MHE	materials-handling equipment
Military Standard Transportation and Movement Procedures	DOD Regulation 4500.32-R provides policies and procedures required to manage and control movement of materiel through the Defense Transportation System. Applicable to all military services.
Military Standard Requisitioning and Issue Procedures	DOD Manual 4140.17M establishes policy and procedures to ensure uniform requisitioning and issuance of materiel throughout the DOD. Applicable to all military services.
MILSTAMP	Military Standard Transportation and Movement Procedures
MIL-STD	military standard
MILVAN	military-owned demountable container
MISC	miscellaneous
MOBCON	mobilization movement control
mobilization movement control	A DA-approved program to establish a movement control center in each STARC. The SMCC will collect, analyze, and consolidate all DOD organic movements and develop a master movement plan for mobilization and deployment.
Mobilization of the armed forces:	<p>a. <u>Selective mobilization</u>. Expansion of the active armed forces resulting from action by Congress and/or the President to mobilize Reserve Component units, IRRs, and the resources needed for their support to meet the requirements of a domestic emergency that is not the result of an enemy attack.</p> <p>b. <u>Presidential call-up of 100,000 selected reservists (not considered a mobilization)</u>. The President may augment the active forces by a call-up of units or individuals of the Selected Reserve, up to 100,000 personnel, not to exceed 90 days, to meet the requirements of an operational mission.</p> <p>c. <u>Partial Mobilization</u>. Expansion of the active armed forces resulting from action by Congress (up to full mobilization) or by the President (not more than 1,000,000) to mobilize Ready Reserve component units, individual reservists, and the resources needed for</p>

their support to meet the requirements of a war or other national emergency involving an external threat to the national security.

d. Full Mobilization. Expansion of the active forces resulting from action by Congress and the President to organize and/or generate additional units or personnel beyond the existing force structure, and the resources needed for their support, to meet the total requirement of a war or other national emergency involving an external threat to the national security.

**mobilization station
(supporting installation)**

The designated military installation (active, semi-active, or state-owned and/or controlled) to which an RC unit is moved for further processing, organizing, equipping, training, and employment, and from which the unit may move to an SPOE/APOE.

**Mobilization Stationing
Planning System**

A FORSCOM computer subsystem supported by WWMCCS.

MOD	Mobilization and Operations Directorate
MOS	military occupational specialty
MOU	memorandum of understanding
MP	military police
MPF	maritime prepositioning force
mph	miles per hour
MS	mobilization station
MSC	Military Sealift Command
MSCO	Military Sealift Command Office
MSL	military shipment label
MSR	main supply route
MTMC	Military Traffic Management Command
MTMCTEA	Military Traffic Management Command Transportation Engineering Agency
MTOE	modified table of organization and equipment
MUSARC	major United States Army Reserve Command

National Military Command Center	Located in the Pentagon and operated by JCS in support of the National Command Authorities.
NBC	nuclear, biological, chemical
NCA	National Command Authority
NCO	noncommissioned officer
NCOIC	noncommissioned officer in charge
NEW	net explosive weight
NGB	National Guard Bureau
NM	nautical miles
NMCS	National Military Command System
NRP	non-unit related personnel
NSN	national stock number
NTAT	not to accompany troops
OCONUS	outside continental United States
OF	optional form
OIC	officer in charge
OOTW	operations other than war
OPCON	operational control
OPLAN	operation plan
OPORD	operation order
OPSEC	operations security
Outsize cargo	Exceeds the dimensions of oversize cargo and requires the use of a C-5 aircraft.
OVE	on-vehicle equipment
oversize cargo	Exceeds the usable dimensions of a 463L pallet loaded to the design height of 96 inches but is equal to or less than 1,090 inches long, 117 inches wide, and 105 inches high. This cargo is air-transportable on C-5, C-141, C-130, B-747, and DC-10 aircraft.

Pam	pamphlet
PBCR	portable bar code reader
PC	personal computer; piece
PERSCOM	United States Total Army Personnel Command
PLL	prescribed load list
PMCS	preventive maintenance checks and services
POC	point of contact
POD	port of debarkation
POE	port of embarkation
POL	petroleum, oils, lubricants
POM	preparation for overseas movement
POV	privately owned vehicles
Protected cargo	<p>Those items designated as having characteristics which require that they be identified, accounted for, secured, segregated, or handled in a special manner to ensure their safeguard or integrity. Protected cargo is subdivided into controlled, pilferable, and sensitive cargo as defined below:</p> <p><u>Controlled Cargo</u>: Items which require additional control and security as prescribed in various regulations and statutes. Controlled items include money, negotiable instruments, narcotics, registered mail, precious metal alloys, ethyl alcohol and drug abuse items.</p> <p><u>Pilferable Cargo</u>: Items which are vulnerable to theft because of their ready resale potential. Pilferable items include cigarettes, alcoholic beverages, cameras, electronic equipment, and so on.</p> <p><u>Sensitive Cargo</u>: Items such as small arms, ammunition, and explosives which have a ready use during civil disturbances and other types of domestic unrest or for use by criminal elements and which, if in the wrong hands, present a definite threat to public safety.</p>
PSA	port support activity
PSC	port security company
PT	palletized

PWRS	pre-positioned war reserve stock
QD	quantity distances
QUADCON	quadruple container
quick transportation	Long-term contract airlift service within CONUS to move cargo in support of the logistics systems for the military services, primarily Navy and Marine Corps.
RAA	redeployment assembly area
RC	reserve component
RDD	required delivery date
ready reserve force	Part of MSC program. Quick response ships in the national defense reserve fleet, maintained in a high state of readiness by the maritime administration for activation in 5, 10, or 20 days.
Reg	regulation
RLD	ready-to-load date
ROAMS	Replacement Operations Automation Management System
RO/RO	roll on/roll off
RP	release point
RRF	ready reserve force
RSO&I	reception, staging, onward movement, and integration
RT	rough terrain
S3	operations and training officer (US Army)
S4	supply officer (US Army)
SAEDA	subversion and espionage directed against the US Army
SA	Secretary of the Army
Sealift Readiness Program	A program under public law or as a precondition for carrying military cargo it requires US ship owners and US flag merchant ships to commit to being available to the DOD in a prescribed number of days after call-up by the SECDEF, in coordination with the Secretary of Transportation.

SEAVAN	commercial- or government-owned (or leased) shipping container
SECDEF	Secretary of Defense
S/EDRE	sea emergency deployment readiness exercise
SERE	survival, escape, resistance, and evasion
SF	standard form
SGLI	Service Members Group Life Insurance
SI	supporting installation
SIDPERS	Standard Installation Division Personnel System
SIOP	Special Integrated Operational Plan
SMCC	STARC Movement Control Center
SOFA	Status of Forces Agreements
SOP	standing operating procedure
SP	start point
SPOD	seaport of debarkation
SPOE	seaport of embarkation
SRP	soldier readiness processing; Sealift Readiness Program
SSA	supply support activity
SSSC	self-service supply center
STAMIS	Standard Army Management Information System
STANAG	Standardization Agreement
standby reserve	Those units and members of the RC (other than those in the ready reserve or retired reserve) who are liable for active duty only after the Secretary of the Army, with the approval of the SECDEF, determines that there are not enough of the required kinds of units or members in the required category in the ready reserve who are readily available.
STARC	State Area Command

State Area Command	A mobilization entity within the ARNG state headquarters and headquarters detachment that is ordered to active duty when ARNG units in that state are alerted for mobilization. It controls mobilized ARNG units from home station until arrival at mobilization station. It must also plan and execute military support for civil defense, land defense plans under the respective area commander, and military family assistance.
SUN	shipment unit number
supporting installation	An installation or activity that provides specified types of support to off-post units and activities within a specific geographic area.
TA	theater Army
TAA	tactical assembly area
TAACOM	Theater Army Area Command
TACCS	Tactical Army Combat Service Support Computer System
TALCE	tanker airlift control element
TAMCA	Theater Army Movement Control Agency
TAMMC	Theater Army Material Management Center
TAT	to accompany troops
TB	technical bulletin
TC-ACCIS	Transportation Coordinator-Automated Command and Control Information System
TC-AIMS	Transportation Coordinator's Automated Information for Movements System
TCMD	transportation control and movement document
TCN	transportation control number
TDA	table of distribution and allowances
TM	technical manual
TOE	table of organization and equipment
TOFC	trailer on flatcar
TOLS	Terminals On-Line System

TPFDD	time-phased force deployment data
TPFDL	time-phased force deployment list
TRADOC	United States Army Training and Doctrine Command
TRANSCOM	Transportation Command
transportation command	(See USTRANSCOM).
Transportation Component Command	One of the three components of USTRANSCOM. The Army component is MTMC. The Air Force and Navy components are AMC and MSC, respectively.
Transportation Coordinator-Automated Command and Control Information System	The Army's automated initiative to accomplish transportation functions at the installation level. TC-ACCIS will allow units to create, update, or modify unit data for peacetime, mobilization, and deployment.
Transportation Coordinator-Automated Information and Management System	The joint service initiative to provide units the capability to generate and maintain movement data for peacetime, mobilization and deployment, and command and control reporting.
transportation control and movement document (DD Form 1384)	Provides the airlift clearance authority and AMC with advanced information on all shipments entering the AMC system, and provides internal processing and onward movement tracking.
TSM	Terminal Support Module
TSS	trim, stability, and stress
TTBde	transportation terminal brigade
UCMJ	Uniform Code of Military Justice
UIC	unit identification code
ULN	unit line number
UMC	unit movement coordinator
UMD	unit movement data
UMO	unit movement officer
UMT	unit movement team

Unilateral	A plan or action involving only one country.
United States Transportation Command	A unified command which combines the assets of MSC, MTMC, and AMC under a unified commander. USTRANSCOM is responsible for ensuring proper planning and execution of strategic mobility forces.
US	United States (of America)
USACOM	United States Atlantic Command
USAMC	United States Army Materiel Command
USAREUR	United States Army Europe
USAR	United States Army Reserve
USARC	United States Army Reserve Command
USARPAC	United States Army Pacific
USARSOUTH	United States Army South
USCENTCOM	United States Central Command
USCG	United States Coast Guard
USCS	United States Customs Service
USDA	United States Department of Agriculture
USEUCOM	United States European Command
USPACOM	United States Pacific Command
USR	Unit Status Report
USSOUTHCOM	United States Southern Command
USTRANSCOM	United States Transportation Command
VA	Virginia
WESTCOM	Western command
WIN	WWMCCS intercomputer network
WPS	Worldwide Port System
WWMCCS	Worldwide Military Command and Control System

yd yard

Zulu Time (Z) Greenwich, England mean time; coordinated universal time.



Bibliography

SOURCES USED

These are the sources quoted or paraphrased in this publication.

AFJMAN 24-204/TM 38-250/NAVSUP Pub 505/MCO P4030.19E/DLAM 4145.3. *Preparing Hazardous Materials for Military Air Shipments.* 25 November 1994.

AR 5-9. *Intraservice Support Installation Area Coordination.* 1 March 1984.

AR 40-61. *Medical Logistics Policies and Procedures.* 30 April 1986.

AR 40-562. *Immunizations and Chemoprophylaxis.* 7 October 1988.

AR 55-29. *Military Convoy Operations in CONUS.* 3 September 1971.

AR 55-80. *Highways for National Defense.* 15 December 1982.

AR 55-162. *Permits for Oversize, Overweight, or Other Special Military Movements on Public Highways in the United States.* 1 January 1979.

AR 55-355. *Defense Traffic Management Regulation.* 31 July 1986.

AR 59-105/AFR 76-7/OPNAVINST 4630.13D/MCO 4660.2. *Air Terminals and Aerial Ports.* 18 April 1985.

AR 200-1. *Environmental Protection and Enhancement.* 23 April 1990.

AR 200-2. *Environmental Effects of Army Actions.* 23 December 1988.

AR 220-1. *Unit Status Reporting.* 31 July 1993.

AR 220-10. *Preparation for Oversea Movement of Units (POM).* 15 June 1973.

AR 380-5. *Department of the Army Information Security Program.* 25 February 1988.

AR 600-8-101. *Personnel Processing (In-and-Out and Mobilization Processing).* 12

December 1989.

AR 614-30. *Oversea Service.* 16 March 1988.

AR 710-2. *Inventory Management Supply Policy Below the Wholesale Level.* 31 January 1992.

CFR 33. *Code of Federal Regulations - Navigation and Navigable Water.* 1 July 1994.

CFR 49. *Code of Federal Regulations - Transportation.* 1 October 1994.

CTA 8-100. *Army Medical Department Expendable/Durable Items.* 31 August 1994.

CTA 50-900. *Clothing and Individual Equipment.* 1 September 1994.

DA Pam 740-1. *Instructional Guide to Basic Military Preservation and Packing.* 29 June 1990.

DOD Reg 4500.32-R, Volume I. *Military Standard Transportation and Movement Procedures.* 15 March 1987.

DOD Reg 5030.49-R. *Customs Inspection.* 27 May 1977.

[**FM 9-207.**](#) *Operation and Maintenance of Ordnance Materiel in Cold Weather (0 Degrees F to Minus 65 Degrees F).* 10 August 1989.

[**FM 21-10.**](#) *Field Hygiene and Sanitation.* 22 November 1988.

[**FM 55-9.**](#) *Unit Air Movement Planning.* 5 April 1993.

[**FM 55-10.**](#) *Movement Control in a Theater of Operations.* 8 December 1992.

FM 55-12. *Movement of Units in Air Force Aircraft.* 10 November 1989.

[**FM 55-15.**](#) *Transportation Reference Data.* 9 June 1986.

[**FM 55-17.**](#) *Terminal Operations Coordinator's Handbook.* 9 September 1990.

[**FM 55-30.**](#) *Army Motor Transport Units and Operations.* 14 March 1980.

FM 55-312. *Military Convoy Operations in the Continental United States.* 3 April 1991.

[**FM 90-3.**](#) *Desert Operations.* 24 August 1993.

[**FM 100-5.**](#) *Operations.* 14 June 1993.

FM 100-16. *Support Operations: Echelons Above Corps.* 16 April 1985.

FM 100-17. *Mobilization, Deployment, Redeployment, Demobilization.* 28 October 1992.

FORSCOM Directive 525-5. *(C) Alert Force Requirements and Response Standards.* 1 August 1992.

FORSCOM Regulation 55-2. *Unit Movement Data Reporting and System Administration.* 1 October 1993.

MIL-STD-129. *Marking for Shipment and Storage.* 25 September 1984.

MTMCTEA Pamphlet 55-19. *Tie-Down Handbook for Rail Movements.* June 1991.

TB 43-0118. *Field Instructions for Painting and Preserving Communications-Electronics Equipment.* 15 June 1986.

TB 43-0209. *Color, Marking and Camouflage Painting of Military Vehicles, Construction Equipment, and Materials Handling Equipment.* 31 October 1990.

TB 43-0239. *Maintenance in the Desert.* 15 October 1990.

TB 55-46-1. *Standard Characteristics (Dimensions, Weight, and Cube) for Transportability of Military Vehicles and Other Outsize/Overweight Equipment (In TOE Line Item Number Sequence).* 30 January 1994.

TB 55-46-2. *Standard Transportability Characteristics (Dimensions, Weight, and Cube) for Military Vehicles and Equipment (In NSN Sequence).* 15 January 1994.

TB 55-2200-001-12. *Transportability Guidance for Application of Blocking, Bracing, and Tie-Down Materials for Rail Transport.*

TB 750-651. *Use of Antifreeze Solutions, Antifreeze Extender Cleaning Compounds and Test Kit in Engine Cooling Systems.* 12 February 1989.

TM 9-6140-200-14. *Operator's, Unit, Intermediate Direct Support and Intermediate General Support Maintenance Manual for Lead-Acid Storage Batteries.* 13 July 1989.

TM 750-254. *Cooling Systems: Tactical Vehicles.* 29 March 1972.

STANAG 2926. *Procedures for the Use and Handling of Freight Containers for Military Supplies.* 17 February 1987.*

AFM 28-346, Vol. I/II. *Contingency Operation/Mobility Planning and Execution System (COMPES), Cargo Movement Operations System (CMOS), Computer Aided Load Manifesting (CALM).* 31 October 1989.**

AMCP 55-41. *Civil Reserve Air Fleet (CRAF) Load Planning Guide.* 30 September 1987.

DOCUMENTS NEEDED

These documents must be available to the intended users of this publication.

DA Form 581. *Request for Issue and Turn-In of Ammunition.* August 1989.

DA Form 1594. *Daily Staff Journal or Duty Officer's Log.* November 1962.

DA Form 1610-R. *Estimate and Cost Statement Strategic and Critical Materials Special Projects.* November 1969.

DA Form 2404. *Equipment Inspection and Maintenance Worksheet.* April 1979.

DA Form 2765-1. *Request for Issue or Turn-In.* April 1976.

DA Form 3645. *Organizational Clothing and Individual Equipment Record.* October 1991.

DA Form 3955. *Change of Address and Directory Card.* February 1979.

DA Form 4886. *Issue-in-Kind-Personal Clothing Record.* May 1993.

DA Form 5748-R. *Shipment Unit Packing List and Load Diagram.* March 1989.

DD Form 93. *Record of Emergency Data.* May 1989.

DD Form 603. *Registration of War Trophy Firearms.* October 1951.

DD Form 1253. *Military Customs Inspection (Label).* April 1977.

DD Form 1253-1. *Military Customs Inspection (Tag).* April 1977.

DD Form 1265. *Request for Convoy Clearance.* January 1959.

DD Form 1266. *Request for Special Hauling Permit.* January 1959.

DD Form 1384. *Transportation Control and Movement Document.* April 1966.

DD Form 1387. *Military Shipping Label.* November 1986.

DD Form 1750. *Packing List.* September 1970.

- DD Form 1854.** *US Customs Accompanied Baggage Declaration.* April 1977.
- DD Form 1970.** *Motor Equipment Utilization Record.* April 1981.
- DD Form 2130-1.** *C-5 A/B Cargo Manifest.* December 1988.
- DD Form 2130-2.** *C-130 A/B/E/H Cargo Manifest.* December 1988.
- DD Form 2130-3.** *C-141B Cargo Manifest.* December 1988.
- DD Form 2130-5.** *DC 10-10/30CF Cargo Manifest.* July 1991.
- DD Form 2130-6.** *KC-10A Cargo (17 Pallets Configuration) Manifest.* December 1988.
- DD Form 2130-7.** *KC-10A Cargo (23 Pallets Configuration) Manifest.* December 1988.
- DD Form 2130-8.** *DC 8-50 Series F/CF Cargo Manifest.* December 1988.
- DD Form 2130-9.** *DC 8-61/71-63/73F/CF Cargo Manifest.* December 1988.
- DD Form 2130-10.** *DC 8-62CF Cargo Manifest.* December 1988.
- DD Form 2130-11.** *B707-300C Cargo Manifest.* December 1988.
- DD Form 2130-12.** *B747-100F/200C/200F Cargo Manifest.* December 1988.
- DD Form 2133.** *Joint Airlift Inspection Record.* November 1986.
- DD Form 2271.** *Decontamination Tag.* November 1982.
- DD Form 2327.** *Unit Aircraft Utilization Plan.* February 1984.
- OF 346.** *US Government Motor Vehicle Operator's Identification Card.* November 1985.
- SF 91.** *Operator Report on Motor Vehicle Accidents.* November 1976.
- SGLI Form 8286.** *Service Men's Group Life Election and Certificate.* September 1991.

*Mail requests to the Naval Publications and Forms Center (NPFC), 5801 Tabor Avenue, Philadelphia, PA 19120. Use DD Form 1425 to requisition the documents.

**Request Air Force publications using DD Form 1149 (Requisition and Invoice/Shipping Document) and forward to Air Force Publications Distribution Center, Baltimore, MD

21220.

***Obtain Air Mobility Command Regulations from the Department of the Air Force, ATTN: HQ AMC/DAP, Scott Air Force Base, Illinois 62225-5001.

***Obtain a copy of AMCP 55-41 from the following:

FORSCOM: Commander, US Army Forces Command, ATTN: Publications Stock Room, Building 208, Fort Gillem, Forest Park, Georgia 30050-5000

EUCOM: Commander, EUCOM, ATTN: 1st TMCA, APO New York, New York 09451-0127

TRADOC: Commander, US Army Training and Doctrine Command, ATTN: ATPL-TT, Fort Monroe, Virginia 23651-5000

WESTCOM: Commander, WESTCOM, ATTN: APLG-TR, Fort Shafter, Hawaii 96858-5100

Other Units: HQ AMC/DAPD, Scott Air Force Base, Illinois 62225-5441



FM 55-65
3 OCTOBER 1995

By Order of the Secretary of the Army:

DENNIS J. REIMER
General, United States
Army
Chief of Staff

Official:

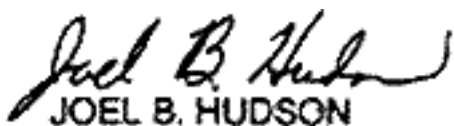
JOEL B. HUDSON

Acting Administrative Assistant
to the
Secretary of the Army
00790

DISTRIBUTION: *Active Army, Army National Guard, and U.S. Army Reserve:* To be distributed in accordance with the initial distribution number 111197, requirements for FM 55-65.